



NONRESIDENT TRAINING COURSE

November 1996



Intelligence Specialist 3 & 2, Volume 1

NAVEDTRA 14127

**FOR INDIVIDUAL USE ONLY
NOT TO BE FURTHER DISSEMINATED**

DISTRIBUTION STATEMENT B: Distribution authorized to U.S. Government agencies only; Administrative/Operational Use; Specific Authority-Office of Naval Intelligence, November 1996. Other requests for this document must be referred to Commanding Officer, Naval Education and Training Professional Development and Technology Center, N311, 6490 Saufley Field Road, Pensacola, FL 32509-5237.

Although the words “he,” “him,” and “his” are used sparingly in this course to enhance communication, they are not intended to be gender driven or to affront or discriminate against anyone.

DISTRIBUTION STATEMENT B: Distribution authorized to U.S. Government agencies only; Administrative/Operational Use; Specific Authority-Office of Naval Intelligence, November 1996. Other requests for this document must be referred to Commanding Officer, Naval Education and Training Professional Development and Technology Center, N311, 6490 Saufley Field Road, Pensacola, FL 32509-5237.

PREFACE

By enrolling in this self-study course, you have demonstrated a desire to improve yourself and the Navy. Remember, however, this self-study course is only one part of the total Navy training program. Practical experience, schools, selected reading, and your desire to succeed are also necessary to successfully round out a fully meaningful training program.

THE COURSE: This self-study course is organized into subject matter areas, each containing learning objectives to help you determine what you should learn along with text and illustrations to help you understand the information. The subject matter reflects day-to-day requirements and experiences of personnel in the rating or skill area. It also reflects guidance provided by Enlisted Community Managers (ECMs) and other senior personnel, technical references, instructions, etc., and either the occupational or naval standards, which are listed in the *Manual of Navy Enlisted Manpower Personnel Classifications and Occupational Standards*, NAVPERS 18068.

THE QUESTIONS: The questions that appear in this course are designed to help you understand the material in the text.

VALUE: In completing this course, you will improve your military and professional knowledge. Importantly, it can also help you study for the Navy-wide advancement in rate examination. If you are studying and discover a reference in the text to another publication for further information, look it up.

*1996 Edition Prepared by
ISC(AW) Scott Chaney*

Published by
NAVAL EDUCATION AND TRAINING
PROFESSIONAL DEVELOPMENT
AND TECHNOLOGY CENTER

**NAVSUP Logistics Tracking Number
0504-LP-026-7870**

Sailor's Creed

“I am a United States Sailor.

I will support and defend the Constitution of the United States of America and I will obey the orders of those appointed over me.

I represent the fighting spirit of the Navy and those who have gone before me to defend freedom and democracy around the world.

I proudly serve my country's Navy combat team with honor, courage and commitment.

I am committed to excellence and the fair treatment of all.”

CONTENTS

CHAPTER	PAGE
1. The Intelligence Specialist	1-1
2. Intelligence Fundamentals	2-1
3. Technical Administration	3-1
4. Security	4-1
5. Mapping, Charting, and Geodesy	5-1
6. Imagery Interpretation	6-1
7. Mensuration Techniques	7-1
8. Automated Information Systems (AIS) Fundamentals	8-1
APPENDIX	
I. Glossary	AI-1
II. The United States Intelligence Organization	AII-1
III. Foreign Intelligence Agencies	AIII-1
IV. The Metric System	AIV-1
V. Map Symbols	AV-1
VI. Reference used to develop this TRAMAN	AVI-1
INDEX	INDEX-1

SUMMARY OF THE INTELLIGENCE SPECIALIST 3&2 TRAMANS

VOLUME 1

Intelligence Specialist 3&2, Volume 1, NAVEDTRA 14127, is unclassified and contains information on fundamentals of intelligence, the intelligence community, administration, security, maps and charts, imagery interpretation, photometric, and basic computer skills.

VOLUME 2

Intelligence Specialist 3&2, Volume 2, NAVEDTRA 14169, will be classified Secret and contain information on operational and strike intelligence. This includes information on dissemination and reporting methods, threat assessments, mission statements, terrorism, and the administration of Sensitive Compartmented Information (SCI).

INSTRUCTIONS FOR TAKING THE COURSE

ASSIGNMENTS

The text pages that you are to study are listed at the beginning of each assignment. Study these pages carefully before attempting to answer the questions. Pay close attention to tables and illustrations and read the learning objectives. The learning objectives state what you should be able to do after studying the material. Answering the questions correctly helps you accomplish the objectives.

SELECTING YOUR ANSWERS

Read each question carefully, then select the BEST answer. You may refer freely to the text. The answers must be the result of your own work and decisions. You are prohibited from referring to or copying the answers of others and from giving answers to anyone else taking the course.

SUBMITTING YOUR ASSIGNMENTS

To have your assignments graded, you must be enrolled in the course with the Nonresident Training Course Administration Branch at the Naval Education and Training Professional Development and Technology Center (NETPDTC). Following enrollment, there are two ways of having your assignments graded: (1) use the Internet to submit your assignments as you complete them, or (2) send all the assignments at one time by mail to NETPDTC.

Grading on the Internet: Advantages to Internet grading are:

- you may submit your answers as soon as you complete an assignment, and
- you get your results faster; usually by the next working day (approximately 24 hours).

In addition to receiving grade results for each assignment, you will receive course completion confirmation once you have completed all the

assignments. To submit your assignment answers via the Internet, go to:

<https://courses.cnet.navy.mil>

Grading by Mail: When you submit answer sheets by mail, send all of your assignments at one time. Do NOT submit individual answer sheets for grading. Mail all of your assignments in an envelope, which you either provide yourself or obtain from your nearest Educational Services Officer (ESO). Submit answer sheets to:

COMMANDING OFFICER
NETPDTC N331
6490 SAUFLEY FIELD ROAD
PENSACOLA FL 32559-5000

Answer Sheets: All courses include one “scannable” answer sheet for each assignment. These answer sheets are preprinted with your SSN, name, assignment number, and course number. Explanations for completing the answer sheets are on the answer sheet.

Do not use answer sheet reproductions: Use only the original answer sheets that we provide—reproductions will not work with our scanning equipment and cannot be processed.

Follow the instructions for marking your answers on the answer sheet. Be sure that blocks 1, 2, and 3 are filled in correctly. This information is necessary for your course to be properly processed and for you to receive credit for your work.

COMPLETION TIME

Courses must be completed within 12 months from the date of enrollment. This includes time required to resubmit failed assignments.

PASS/FAIL ASSIGNMENT PROCEDURES

If your overall course score is 3.2 or higher, you will pass the course and will not be required to resubmit assignments. Once your assignments have been graded you will receive course completion confirmation.

If you receive less than a 3.2 on any assignment and your overall course score is below 3.2, you will be given the opportunity to resubmit failed assignments. **You may resubmit failed assignments only once.** Internet students will receive notification when they have failed an assignment--they may then resubmit failed assignments on the web site. Internet students may view and print results for failed assignments from the web site. Students who submit by mail will receive a failing result letter and a new answer sheet for resubmission of each failed assignment.

COMPLETION CONFIRMATION

After successfully completing this course, you will receive a letter of completion.

ERRATA

Errata are used to correct minor errors or delete obsolete information in a course. Errata may also be used to provide instructions to the student. If a course has an errata, it will be included as the first page(s) after the front cover. Errata for all courses can be accessed and viewed/downloaded at:

<https://www.advancement.cnet.navy.mil>

STUDENT FEEDBACK QUESTIONS

We value your suggestions, questions, and criticisms on our courses. If you would like to communicate with us regarding this course, we encourage you, if possible, to use e-mail. If you write or fax, please use a copy of the Student Comment form that follows this page.

For subject matter questions:

E-mail: n311.products@cnet.navy.mil
Phone: Comm: (850) 452-1001, Ext. 1501
DSN: 922-1001, Ext. 1501
FAX: (850) 452-1370
(Do not fax answer sheets.)
Address: COMMANDING OFFICER
NETPDTC (CODE N311)
6490 SAUFLEY FIELD ROAD
PENSACOLA FL 32509-5237

For enrollment, shipping, grading, or completion letter questions:

E-mail: fleetservices@cnet.navy.mil
Phone: Toll Free: 877-264-8583
Comm: (850) 452-1511/1181/1859
DSN: 922-1511/1181/1859
FAX: (850) 452-1370
(Do not fax answer sheets.)
Address: COMMANDING OFFICER
NETPDTC (CODE N331)
6490 SAUFLEY FIELD ROAD
PENSACOLA FL 32559-5000

NAVAL RESERVE RETIREMENT CREDIT

If you are a member of the Naval Reserve, you will receive retirement points if you are authorized to receive them under current directives governing retirement of Naval Reserve personnel. For Naval Reserve retirement, this course is evaluated at 14 points:

12 points upon satisfactory completion of unit 1, assignments 1 through 8; and

2 points upon satisfactory completion of unit 2, assignment 9.

(Refer to *Administrative Procedures for Naval Reservists on Inactive Duty*, BUPERSINST 1001.39, for more information about retirement points.)

COURSE OBJECTIVES

In completing this nonresident training course, you will demonstrate a knowledge of the subject matter by correctly answering questions on the following: The Intelligence

Specialist rating; Intelligence Fundamentals; Technical Administration; Security; Maps, Charts, and Geodesy; Imagery Interpretation; Mensuration Techniques; and Automated Information Systems Fundamentals.

Student Comments

Course Title: Intelligence Specialist 3 & 2, Volume 1

NAVEDTRA: 14127 **Date:** _____

We need some information about you:

Rate/Rank and Name: _____ SSN: _____ Command/Unit _____

Street Address: _____ City: _____ State/FPO: _____ Zip _____

Your comments, suggestions, etc.:

Privacy Act Statement: Under authority of Title 5, USC 301, information regarding your military status is requested in processing your comments and in preparing a reply. This information will not be divulged without written authorization to anyone other than those within DOD for official use in determining performance.

NETPDTC 1550/41 (Rev 4-00)

CHAPTER 1

THE INTELLIGENCE SPECIALIST

LEARNING OBJECTIVES

Upon completing this chapter you should be able to do the following:

- *Explain the challenge of today's IS personnel as it relates to the collection and analysis of intelligence information.*
 - *Describe some of the billets and duty assignments to which IS personnel maybe assigned.*
 - *Identify the NECs that maybe assigned to qualified IS personnel.*
 - *Identify sources of information pertaining to intelligence subjects.*
-

Every country has one or more reasons for wanting or needing to know certain information about its neighbors, both friends and potential enemies. This information may be about politics, economics, military capabilities, or any combination of these. When this information is gathered to be used for the well-being of the gathering country, it is called *intelligence*. There are several types of intelligence, such as *industrial, political, strategic, operational, and tactical*. In this TRAMAN, we will limit our discussion to the types that pertain primarily to the U.S. Navy.

The Intelligence Specialist (IS) rating provides the fleet with skilled personnel who are trained primarily to support the operational intelligence environment, both ashore and afloat. That means providing intelligence reports that will help commanders to make sound decisions concerning their assigned missions. Basic skills include interpreting images, planning missions, analyzing threats, providing intelligence security and administration, and giving briefings.

CHALLENGES OF TODAY'S IS

Prior to the collapse of the former Soviet Union, U.S. intelligence needs were easy to define and set. Since the collapse, however, things have changed. The current threat does not come in such a neat and predictable package. Some of the intelligence-

gathering methods used against the former Soviet Union still work against current adversaries, but others don't. As a result, today's IS is faced with a different, but no less important, type of challenge. Besides being able to collect, process, and disseminate intelligence information efficiently, you must be flexible, be able to adapt to the situation, and be able to make competent decisions.

You will not be expected to develop these skills overnight; you must take the time to understand the capabilities of your adversary. You must know his tactics and procedures and be able to anticipate potential problems that may arise. You must also know the capabilities and structure of your own forces. By knowing as much as possible about both your own forces and your adversary, you will be in the best position to provide sound advice to your commanders. Having this knowledge, as well as trust in your own abilities, will help you greatly in developing your personal goals and professional aspirations.

BILLETS AND DUTY ASSIGNMENTS

The IS rating includes a variety of administrative and technical functions. These functions overlap in some instances, in that they combine to form particular billet within the IS community.

BILLETS

Some of the billets to which you may be assigned are listed below, along with their typical job responsibilities.

- **IMAGERY INTERPRETATION**— Analyze and report on imagery from multiple sources. Use and operate a light table and soft-copy imagery exploitation systems. Maintain and refer to publications in support of initiation and platform identification. Categorize and measure objects of intelligence interest found on imagery. Prepare and maintain imagery interpretation reports.
- **OPERATIONAL INTELLIGENCE**— Analyze and combine multi-source intelligence information in order to produce operational intelligence (OPINTEL). Perform OPINTEL watchstanding, Sensitive Compartmented Information (SCI) security, threat assessment, message preparation, and reporting. Use Command, Control, Communications, Computer, and Intelligence (C4I) methodology; and maintain an all-source intelligence plot.
- **INDEPENDENT DUTY**— Provide intelligence support aboard surface ships without an assigned intelligence officer (IO). Serve as the assistant to the IO assigned to an afloat staff or selected shore command. Provide evaluations and briefs of the current or projected threat within the operational environment. Conduct all-source contact analysis, correlation, and sanitization in support of C4I integration. Generate intelligence reports and maintain the current intelligence library, as well as coordinate shipboard intelligence training. Manage the ship's intelligence collection program.
- **DEFENSE ATTACHE STAFF**— Operating under the guidance of the Defense Human Intelligence (HUMINT) System (DHS), support the attaché staff in the collection, reporting, and administration of embassy activities within a given country. Conduct liaison with U.S. and foreign service personnel. Perform protocol duties, as required.
- **SECURITY**— Apply adjudication principles, manage billets, and prepare background investigation forms. Administer the accreditation, inspection, and documentation of the Special Security Office (SSO) processes. Ensure that physical security requirements are maintained at all times.
- **STAFF**— Provide support to the staff intelligence officer. Conduct briefings, maintain intelligent files and publications. Conduct liaison with the ship's intelligence division.
- **EOD SUPPORT**— Provide direct support to the explosive ordnance units. Supervise intel support for operations. Maintain intel files and publications. Conduct regional threat analysis and maintain all-source intelligence plot.
- **SEAL TEAM SUPPORT**— Provide support, operational and training requirements for the team. Supervise intel support for operations. Maintain intel files and publications. Conduct regional threat analysis and maintain all-source intelligence plot.
- **INSTRUCTOR**— Serve as the subject matter expert in any of the above listed skills: (Further information is provided in the "Duty Assignment" section of this chapter.)
- **INTELLIGENCE ADMINISTRATION**— As intelligence librarian, maintain and control access to intelligence publications and associated materials. Provide additional administrative services as required by the IO.
- **NETPDTC**— Upon advancing to the senior IS paygrades, you may be selected for assignment as a writer to the Naval Education and Training Professional Development and Technology Center (NETPDTC) in Pensacola, Florida, where you will write training manuals or advancement examination.

These are just a few of the billets in the IS rating. As you advance in your career, keep the following statement in mind: To have a rewarding career, approach each billet to which you may be assigned with enthusiasm and the determination to make it the best billet in the intelligence field.

DUTY ASSIGNMENTS

As an Intelligent Specialist, you can expect a wide variety of interesting duty assignments. For example, you may be assigned to the intelligence center aboard an aircraft carrier; to one of the amphibious assault (LHA) ships; a cruiser or destroyer; or to an attack, reconnaissance, or patrol squadron.

Your duty station could also be at one of the shore-based intelligence centers, such as the Office of Naval Intelligence; Atlantic Intelligence Command; Joint Intelligence Center, Pacific; Joint Analysis Center; or any of the numerous staffs in the United States and overseas. If you qualify, you may even be assigned to one of the many attachés throughout the world.

You may have the opportunity for assignment to one of the Navy's intelligence schools, either as an instructor or as a student. Assignment to the schoolhouse will advance your personal knowledge of the IS field as well as prepare you for more responsible duty assignments. In the following paragraphs, we will briefly describe each of the four schools to which an IS may be assigned:

- **IS "A" SCHOOL** —Located at the Navy and Marine Corps Intelligence Training Center (NMITC), Dam Neck, Virginia. The course is 16 weeks long and is designed to give the new IS the basic knowledge and vocabulary needed in the intelligence field. Selected "C" schools are also taught at NMITC. IS "A" school is required for job entry into the IS rating.
- **DSIATP COURSE** —The Defense Sensor Interpretation and Training Program course is a 12-week course taught at Goodfellow Air Force Base, San Angelo, Texas. The objective of this course is to provide advanced training in multi-sensor interpretation.
- **ATTACHE STAFF OPERATIONS COURSE** —This is a 6-week course required for IS personnel who are assigned to or enroute to attaché assignments. The objective of the course is to train military personnel for duty as support personnel in the Defense Attaché System.
- **FITCPAC** —The Fleet Intelligence Training Center, Pacific, is located in San Diego, California. It provides a variety of follow-on intelligence training suited to the needs of Pacific theater of operations.

Considering the wide range of billets and duty assignments within the intelligence field, you will handle vast amounts of intelligence material. Much of this material has a high security classification and requires that personnel assigned to work with it be fully cleared and indoctrinated in the proper procedures for handling classified material. You must always be security conscious and must avoid discussing classified information during leisure hours and with persons not having a need to know. The handling and accountability of classified material require that you *always* devote your attention to the careful, thorough performance of all assigned tasks. Consult the *Department of the Navy, Information and Personnel Security Program Regulation, OPNAVINST 5510.1*, for guidance on the handling of classified material.

NAVY ENLISTED CLASSIFICATIONS (NECS)

Intelligent Specialists who meet the prescribed requirements may be assigned one or more of the following NECs:

- IS-3901 Satellite Sensor Interpreter;
- IS-3905 Independent Surface Warfare Operational Intelligence (OPINTEL) Analyst;
- IS-3907 OSIS Baseline Upgrade (OBU) User/Analyst;
- IS-3910 Naval Imagery Interpreter;
- IS-3922 Navy Tactical Command System-Afloat (NTCS-A) Integrated Data Base (IDB) Analyst;
- IS-3923 NTCS-A Strike Planning Applications Analyst;
- IS-3924 NTCS-A OPINTEL Analyst;
- IS-3925 Digital Imagery Workstation suite Afloat (DIWSA).

These NECs are normally assigned after you have successfully completed specific schools and training.

See figure 1-1. Individuals who qualify for the NECs can expect to be assigned to interesting and challenging billets, where their special skills will be used. However, don't lose sight of your responsibilities to know your rate overall. A well-rounded knowledge of rating requirements will help prepare you for advancement opportunities. Refer to the *Manual of Navy Enlisted Manpower and Personnel Classifications and Occupational Standards*, NAVPERS 18068F, for a complete explanation of the above listed NECs.

SOURCES OF INFORMATION

As you study this training manual, keep in mind that the information presented is, in most cases, in support of only the minimum task requirements for the IS rating. A variety of publications are available to you, should you desire more in-depth study. Also remember that no single publication will provide you with all the information you'll need about the Intelligence Specialist rating. Rather, you should learn *where* to look for accurate and up-to-date information on all subjects pertaining to the IS field. The *Bibliography for Advancement Study* (Bib), available from your ESO, provides a comprehensive listing of publications that are required for examination study purposes, but there are many other publications available. Two publications in which you will find extremely valuable sources of information are as follows:

- *Register of Intelligence Publications*, DDS-2600-37-YR;

- *Naval Intelligence Products Register* (NIPR), ONI-2600A-001A-YR.

These documents will not provide you with information on a particular subject. Rather, they will provide you with a comprehensive listing of publications that are available on a wide variety of intelligence subjects.

All publications listed in the *Bibliography for Advancement Study* should be available to you through your education services office, division officer, personnel office, intelligence office, or intelligence library. However, if a given publication is not available at your command, it can be ordered from the Defense Intelligence Agency (DIA) or the Office of Naval Intelligence (ONI).

Make sure that any source publication you use for study purposes is current. Studying canceled or obsolete information will not help you to perform efficiently or to advance.

SUMMARY

Today's Intelligence Specialist will be confronted with an endless number of challenges. The better qualified and prepared you are, the more you'll contribute to your command and yourself.

With the advent of new technologies and data systems, the emphasis on proper training will continue to grow. Both NMITC and FITCPAC provide excellent courses of instruction to support these technologies and

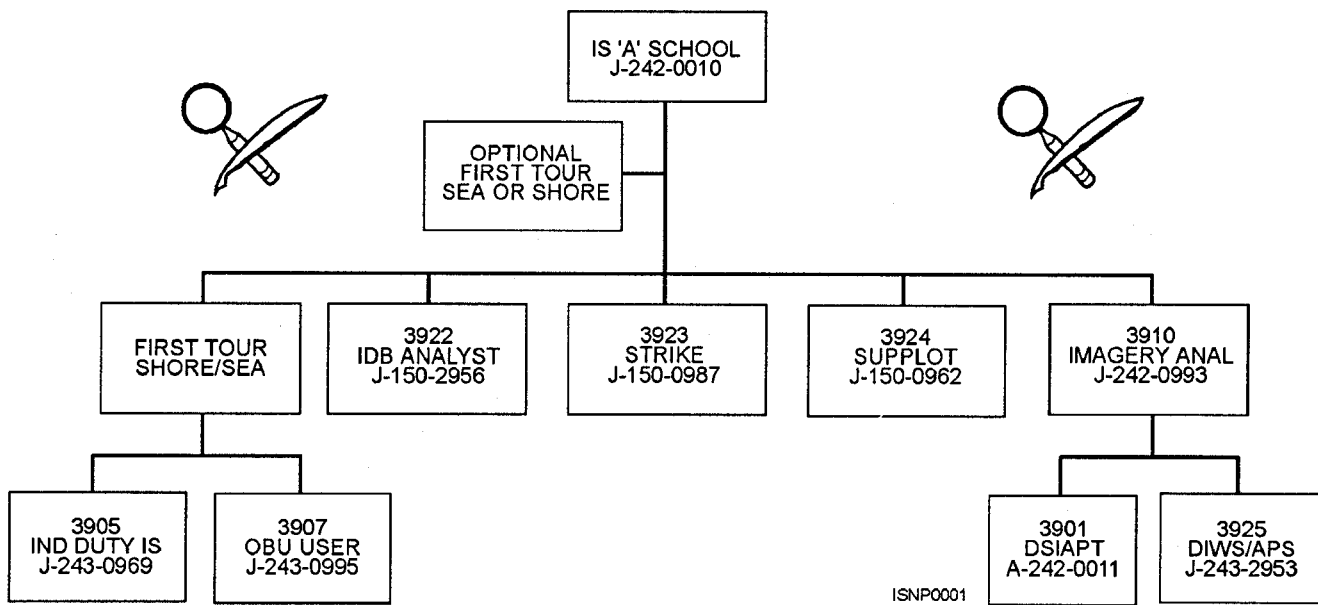

Figure 1-1.—IS NEC pipeline training.

methodologies. However, the importance of on-the-job training can't be understated.

A wide range of billets are available to you, both shipboard and ashore. This variety of assignments can help make you a well-rounded sailor and provide the best avenue to advancement. It is up to you to make your assignment the best job in the Navy.

At a time of declining resources, we, as Intelligence Specialists, are being asked to do more with less. We, as a community, must become more flexible, responsive, and innovative than we have ever been in the past. Only in this way can we provide the high quality of intelligence that our commanders have come to expect.

CHAPTER 2

INTELLIGENCE FUNDAMENTALS

LEARNING OBJECTIVES

Upon completing this chapter you should be able to do the following:

- *Identify the types of military intelligence.*
 - *Describe the processes used in collecting and analyzing intelligence information.*
 - *Determine the impact of intelligence collecting within the operating forces in the U.S.*
-

In chapter 1, we defined and briefly described *intelligence* as it applies to national security. In this chapter, we will begin to explain how intelligence is gathered and analyzed, and your role in those processes.

As an Intelligence Specialist, you will be primarily concerned with a specific application of intelligence, within the guidelines of the National Command Authority (NCA). To perform your duties well, you must first have a general understanding of what intelligence is and how it is gathered and used. Our goal in this chapter is to give you that understanding.

INTELLIGENCE AS A BODY OF KNOWLEDGE

Recall from chapter 1 that the term *intelligence* pertains to certain types of information used for the benefit of the country that gathers it. Within the intelligence-gathering community, however, “intelligence” can have either of two meanings. Intelligence can be either the information itself (a body of knowledge) or the methods used to gather the information. In this chapter, we will discuss both connotations.

Remember, intelligence as a body of knowledge deals with information about an enemy country, a potentially hostile country, or a possible area of operations. Our government and military leaders use the information in planning and carrying out their missions.

Intelligence knowledge can generally be divided into two broad categories: political and military. Political intelligence deals with information that the President and his advisors can use to influence the actions of other countries during peacetime situations. Political intelligence can be organized by time; that is, past, present, or future (estimative). It can also be organized by subject (internal political struggles, monetary problems, etc.).

Military intelligence is information, such as geographic data, military strengths and weaknesses, and feelings of the population for the existing government, that the U.S. military can use in planning and carrying out missions. For our purposes here, military intelligence can be divided into the following categories:

- **Strategic intelligence** —intelligence required to form policy and military plans at national and international levels. During Operation Desert Shield, strategic intelligence was used to identify Iraq’s leaders and command and control centers.
- **Operational intelligence**— intelligence required to plan operations within regional theaters or areas of operations. Operational intelligence helps commanders to identify an adversary’s critical operational vulnerabilities and to decide how to best deploy his forces while minimizing risk. Operational intelligence helped senior commanders identify the Iraqi air defense system as a critical vulnerability that, if

destroyed, would neutralize the Iraqi military's ability to counter coalition air power.

- **Tactical intelligence**— intelligence needed to plan component- or unit-level operations, such as the attacking of anti-aircraft missile sites during Desert Storm.
- **Air intelligence**— intelligence needed for strategic or operational planning involving any use of or defense against aircraft.

THE INTELLIGENCE PROCESS

The successful production of intelligence requires both an organization and a procedure for gathering and processing information. In the following paragraphs, we will first discuss the basic intelligence organization; then, we will discuss the procedures, divided into phases, used to gather and process information.

BASIC INTELLIGENCE ORGANIZATION

The basic intelligence organization contains four basic types of units: requirements control authorities (RCAs), intelligence information collectors, intelligence producers, and intelligence vendors. Each unit may consist of an individual or an entire department or agency, or they may be combined. We will discuss the four types of units to help you better understand the interrelationships of actual intelligence organizations and their functions.

Requirements Control Authority (RCA)

Every large undertaking requires someone or some organization to act as director and manager. In the intelligence-gathering field, this responsibility falls on the *requirements control authority* (RCA). An RCA can be either a person or a group. The RCA is charged with overseeing the intelligence process from beginning to end. If the intelligence process is to flow in a way that will ensure proper use of resources, the RCA must oversee every phase. The RCA must determine the validity of requests for intelligence and the type of collection activity best suited to collect the required intelligence information.

Once the information has been collected, the RCA must decide which production agency to task with producing meaningful intelligence. At the end of the

process, the RCA serves as an intelligence vendor to ensure that all users having a need for specified intelligence receive it.

The highest level RCA in the U.S. intelligence community is the National Foreign Intelligence Board (NFIB), headed by the Director of Central Intelligence. Subordinate RCAs manage various portions of the U.S. intelligence effort. Some examples of subordinate RCAs are:

- **National Security Agency (NSA)**—the highest level RCA for managing signals intelligence activities;
- **Defense Intelligence Agency (DIA)**— the highest level RCA for managing U.S. military intelligence (with the exception of signals intelligence and counterintelligence); and
- **Assistant Chief of Staff, Intelligence, Headquarters, USAF**— manager of all USAF intelligence matters, except those that deal with signals intelligence and counterintelligence, **NOTE:** The intelligence staff of any headquarters is an RCA.

Intelligence Information Collectors

Intelligent information collectors are individuals or agencies, either civilian or military, responsible for acquiring information for intelligence purposes. U.S. intelligence information collectors are usually assigned to collection units, with their collection activities limited to a specific geographic area. Each unit attempts to acquire information from a particular type of information source. For example, one unit may be a tactical reconnaissance unit using aircraft to obtain reconnaissance imagery, whereas another unit may monitor foreign news broadcasts. We attempt to restrict knowledge of intelligence-gathering operations only to personnel involved in the operation itself and to those who manage it.

Precise knowledge of current intelligence information collection operations is frequently classified. The primary reason for the secrecy is to deny our opposition knowledge of what we do and do not know about them. Because intelligence often is created by logically relating bits of intelligence information, our opposition would be able to determine the extent of our intelligence if they learned the exact content of our intelligence information. This would give our opposition an advantage in estimating our decision

makers' probable decisions. Another reason for secrecy is that having precise knowledge of our collection operations would give an opposition counterintelligence service a greater opportunity to plant deceiving information to conceal important information. Finally, secrecy helps to protect the collector's human sources.

Intelligence Producers

Intelligence producers are individuals or organizations who provide conclusions based on collected information. Many of them produce intelligence concerning a limited number of subject areas. Some, however, may base their conclusions primarily on the information from only one source type (i.e., DIA, ONI, and Air Force and Army intelligence producers).

Intelligence Vendors

Intelligence vendors are individuals or organizations who communicate intelligence directly to intelligence users. Since intelligence vendors provide the finished products of the entire intelligence community to consumers, they can be thought of as the "retailers" of intelligence. The primary intelligence vendors are the RCAs.

Now, let's discuss the intelligence cycle.

INTELLIGENCE CYCLE

The process of gathering, evaluating, and using intelligence is known as the *intelligence cycle*. The intelligence cycle consists of the following five phases:

- **Planning and direction**— the orderly identification of needed information and the assignment of the gathering task(s);
- **Collection**— the systematic procurement of intelligence information;
- **Processing**— the conversion of collected intelligence information into a form suitable for producing usable intelligence;
- **Production**— the integration, analysis, evaluation, and interpretation of information from all available sources into tailored, usable intelligence; and
- **Dissemination**— the timely distribution of intelligence in suitable form to agencies needing it.

Although these phases overlap somewhat, they serve as convenient guideposts in the total intelligent effort.

Planning and Direction

At the beginning of the intelligence planning and direction phase, a commander must identify and prioritize his/her information requirements. One of the key elements in planning is assessing current and historical intelligence to determine whether or not it satisfies the commander's needs. Any valid need that is not satisfied by existing intelligence (an intelligence gap) will generate a requirement for developing new intelligence. Early discovery of a potential intelligence gap will help highlight the type of asset needed to fulfill the intelligence requirement.

LEVYING REQUIREMENTS.— When users need new intelligence that they cannot develop with their own resources, they express that requirement to an RCA. The three most commonly used modes for expressing requirements for intelligence are Statements of Intelligence Interest (SIIs), Essential Elements of Information (EIs), and Collection Support Requirements (CSRs). We will discuss SIIs and EIs below. For information on CSRs and collection requirements, refer to chapter 3 of the *Intelligence Specialist 1 & C (U)*, NAVEDTRA 12806, and to the *Defense Intelligence Collection Manual (U)*, DIAM 58-1.

SII.— The SII was developed to enable users to register their interest in information reports, nonrecurring finished intelligence, and initial issues of recurring finished intelligence publications. Refer to the *DOD Intelligence Dissemination Program/Reference Service (U)* (DIAR 59-1) for the proper procedures.

EI.— When intelligence is needed quickly, the requirement may not be satisfied by using an SSI or a CSR. In such cases, EIs are used to levy a requirement where timeliness is paramount. Ground forces engaged in combat frequently refer to their intelligence requirements as EIs. When intelligence requirements are included in the intelligence annex to U.S. military operations plans and orders, the requirements are usually identified as EIs. EIs may be expressed orally, by message, or on specified local forms.

An important point to remember is that these formats usually pertain to U.S. operations. If you become involved in a joint operation with allies, your

intelligence counterparts may use a different type of format or form (i.e., request for information [RFI]).

REQUESTS FOR RECURRING FINISHED INTELLIGENCE.— Much of the intelligent users need is available, through the Defense Intelligence Agency (DIA), in recurring finished intelligence publications. The DIA Dissemination Center provides a list of titles and document numbers for these publications. Users may identify needed documents in the DIA Dissemination Center publications list and request them, on an Interagency Document Request, DD Form 1142, following the guidelines provided in the *DOD Intelligence Dissemination Program/Reference Service* (DIAR 59-1). Users needing hard-copy, finished, recurring intelligence documents *not* on the publications list may request them in the same manner, but should add to the DD 1142 the complete title and description of each document. The above requests may be either mailed or faxed.

The DIA Dissemination Center monitors recurring finished hard-copy intelligence requirements for all *requesting* activities. Once each year, the Dissemination Center mails to each activity two copies of the activity's established requirements for finished recurring hard-copy intelligence documents. Each activity verifies the correctness of the listing, makes necessary additions and deletions, and returns one copy to the DIA through appropriate channels.

INTERAGENCY DOCUMENT REQUEST, DD FORM 1142.— As mentioned above, the Interagency Document Request, DD Form 1142, is used to request previously produced finished recurring intelligence publications. It can also be used to request previous issues of intelligence periodicals, existing intelligence studies, manuals (including DIAMs), past changes to manuals, and previously produced handbooks. This form normally is forwarded as an enclosure to a letter.

VALIDATE/NONVALIDATE REQUIREMENT.— Whenever a user requests intelligence or intelligence information, the servicing RCA must determine whether the request is based on a valid need. If the subject of the request is related to the requester's operational mission, the request is usually validated. In fact, most requests for intelligence or intelligence information are approved, since they are based on the obvious intelligence needs of the requester.

INTELLIGENCE AVAILABILITY.— Before the RCA tasks someone to collect intelligence information about the requested subject, he/she will

determine whether or not the intelligence is already available in either RCA files or in files of another vendor. If the intelligence is available, it will be sent to the requester. If the intelligence is not available, the RCA will levy an intelligence information collection requirement on a collection agency.

Collection

Intelligence producers need intelligence information to serve as the raw material for intelligence production. There are usually more outstanding valid requirements for intelligence information collection than there are resources immediately available to satisfy them. Therefore, managing RCAs frequently have to set priorities based on the relative need for the information. These priorities tell the intelligence information collector in which order the tasking requirements should be accomplished. Based on these priorities, the collectors use various human and electronic means at their disposal to gather the requested information.

The United States intelligence information collection priority system is explained in the *Defense Intelligence Collection Manual*, DIAM 58-1. Refer to chapter 3 of *Intelligence Specialist 3 & 2 (U)*, Volume 2, NAVEDTRA 12805, for detailed information on intelligence collection.

In the next two phases of the intelligence cycle, intelligence processing and production, the RCA is responsible for levying the intelligence production requirement on a selected production unit. The RCA is also responsible for understanding the unique production capabilities possessed by each of the various units so that only the best qualified unit is selected to proceed with the production. This is because intelligence production units may specialize in assessing intelligence information and making conclusions on limited subjects or in a fixed geographic area.

Processing

In the intelligence processing phase, incoming information is converted into a form suitable for producing usable intelligence. Some examples of processing are

- translating foreign languages;
- developing film from reconnaissance tactical aircraft;
- generating hard- and soft-copy images provided by electro-optical or infrared sensors; and

- converting raw electronic intelligence data into a standard message form suitable for automatic handling.

Production

During the intelligence production phase, collected intelligence information is transformed into intelligence. Incoming information is first appraised to determine if the source is reliable and if the information in the report is accurate and credible. The information is then analyzed to establish items of truth and to derive conclusions from the comparison of new facts with established facts. Finally, the meaning and significance of the processed information is combined into an intelligence estimate.

LEVYING PRODUCTION REQUIREMENTS.— In managing intelligence production, the RCA is responsible for levying the intelligence production requirement on a production unit. To do this properly, the RCA must understand the unique production capabilities of each unit so that the best qualified unit is selected to proceed with the production. This is because intelligence production units may specialize in assessing intelligence information and making conclusions on limited subjects or in a fixed geographic area.

Optimum management of intelligence resources should result in a clear division of production responsibilities. However, the allocation of money resources to production does not necessarily guarantee produced intelligence of the highest quality. The quality of produced intelligence depends upon the intelligence information provided by the collectors, the qualifications of the producers, the amount of time and funds available, and the competence and diligence of the production managers.

ALLOCATING PRODUCTION RESOURCES.— In a competitive economy, the value of a product can be measured by the price buyers are willing to pay for it. Unfortunately, the value of intelligence cannot be measured so simply. Nevertheless, production managers must estimate its value so that they can give it proper production emphasis. RCAs acting as production managers, allocate resources to individual intelligence producers. Production resource relocation is normally based on the relative value of the intelligence to be produced, compared to the costs of each producer's effort.

RECEIVING AND/OR RETRIEVING INFORMATION.— Intelligence producers need

intelligence information to serve as the raw material for intelligence production. They receive intelligence information distributed to them by RCAs. Within the intelligence producing organization, a distribution system allows intelligence information to reach the individual producers.

In addition to the information routinely distributed to the producers, needed data may also be available within organization files. Production agencies can store previously collected and reported information and retrieve it as necessary.

EVALUATING INTELLIGENCE INFORMATION.— During the evaluation period collected information is appraised in terms of the reliability of the source, the accuracy of the individual facts in the report, and the credibility of the report as a whole.

When intelligence information is evaluated, attention must be paid to considering several crucial issues carefully or the information maybe improperly appraised. Certain information is considered more intrinsically reliable as a basis for making certain conclusions. For instance, actual specimens of a particular type of aircraft would obviously be the best possible source to use when attempting to determine the performance characteristics of that aircraft.

In the absence of pertinent information from an unimpeached, intrinsically reliable source, the coherence theory of truth should be used to determine what items of information are most likely to be true. The coherence theory of truth, or information evaluation, is based on the premise that information confirmed the most often by independent sources is more likely to be true than any conflicting information confirmed by a lesser number of sources.

Sometimes it is not possible to either directly confirm or deny the truthfulness of intelligence information. If the information in question is all that is available, the intelligence producer has little choice other than either to avoid a conclusion in hopes of getting more information or to base a conclusion on the sole piece of available information,

At times, all information pertinent to a particular intelligence problem conflicts. When more than two sources have been exploited, it is occasionally possible to assume that all information from one source reported at one time is likely to be of the same degree of truthfulness and choose information from the best source. The best of several sources should be chosen by comparing all information from those several

sources. The best source is the one having the greatest proportion of confirmed intelligence information.

CONDUCTING PRODUCTION ANALYSIS.—

The next step in the production phase is called analysis. Analysis is similar to evaluation in the sense that an attempt is made to determine the accuracy of the facts in the report. During analysis, however, the producer tries to relate significant facts in the report to information in other reports.

INTEGRATING INTELLIGENCE INFORMATION.—

In the next step of the production phase, the analyst takes analyzed information and tries to form an intelligence pattern on a larger subject. This step is called *integration*. During the integration step, the analyst assembles into a unified whole the facts and relationships identified during analysis.

Much intelligence is determined by reasoning inductively to form general conclusions from many pieces of evidence. If we link true pieces of intelligence information together with sound logic, we can develop intelligence that is true. The problem we encounter, however, is that there is seldom any way we can be absolutely certain that the intelligence we have is true. Even when we evaluate intelligence information in the most careful manner, the best we can do is determine the information that is most likely to be true. Upon this information, we base our intelligence estimates.

Dissemination

Intelligence is of no use if it is not disseminated to users when they need it. Disseminating is communicating.

Some intelligence is disseminated directly to vendors by its producer. When time is very short or the organization is simple, intelligence may be disseminated directly to its users.

Strategic intelligence is usually sent by its producer to an RCA. The RCA may send intelligence to many different intelligence vendors and other RCAs. Each vendor may, in turn, disseminate intelligence to users.

Intelligence may be communicated *orally*, in *writing*, by *graphics*, or by means of models. Electrical telecommunication conveys oral, written, and graphic intelligence great distances with speed. The most effective dissemination uses a combination of these means simultaneously so that the recipient is more likely to retain the information.

ORAL DISSEMINATION.— Oral dissemination might seem to be the best way to distribute intelligence,

but it has certain disadvantages. First, telling an intelligence conclusion to a prospective user is rapid, but it may involve miscommunication. Second, usually there is no permanent record that the intelligence was disseminated to its recipient. Despite its disadvantages, oral dissemination is routine in operational situations when intelligence must be communicated quickly or to many people simultaneously.

Intelligence is often disseminated orally in the following situations:

- In commander's briefings;
- In aircrew briefings;
- By voice radio (usually encrypted);
- By telephone (usually encrypted).

WRITTEN DISSEMINATION.— Obviously, it takes longer to write an intelligence conclusion than it does to say it. Once written, however, intelligence does not usually change in content when it is transmitted from one person to another, as often happens during oral communication.

Written intelligence can be reproduced and sent to many prospective users who may be geographically separated. Electrical transmission of written intelligence helps communicate it rapidly but introduces an added chance of error caused by garble. Another disadvantage of electrical transmission is that it increases the opportunity for the message to be intercepted by unintended listeners.

Intelligence is often disseminated in written form in the following formats:

- Electrical messages;
- Periodicals;
- Standard reference documents;
- Printed electronic data processing output;
- The intelligence annex to an operations plan or order.

GRAPHIC DISSEMINATION.— The adage that "a picture is worth a thousand words" is as true a guide to intelligence dissemination as to other communications. A graphic can communicate best if it is carefully designed and constructed for its purpose. Almost all oral dissemination of intelligence should be accompanied by appropriate graphics. Most often, graphics include writing to draw attention to specific features or to explain individual items.

Intelligence is often disseminated graphically in these forms:

- Maps and charts;
- Graphs, diagrams, and sketches;
- Situation maps;
- Annotated imagery.

DISSEMINATION CRITERIA.— Choosing the most effective means, or combination of means, for disseminating intelligence should depend primarily upon the need for clarity, accuracy, urgency, and security. The choice should be made by weighing all of these factors.

Clarity is always a major goal of intelligence dissemination. However, lack of time may prevent the preparation of ideally complete and neat graphics.

In many instances, accuracy of details included in intelligence is crucial to its use. If possible, long lists of geographic coordinates should not be communicated orally since the likelihood of oral-aural misunderstanding is so great.

Intelligence must always be communicated to its prospective user in a timely manner, preferably before he/she needs the information to make a decision. Time requirements differ in various circumstances. When long-range plans are being formulated, time is not usually so critical. There is generally more time available in which to produce strategic intelligence and prepare it for dissemination. During tactical operations, however, there is usually less time available. Consequently, tactical intelligence ordinarily must be disseminated as quickly as possible.

To benefit the country whose forces produce intelligence, the intelligence must be kept secure. A major advantage of intelligence is that the opponent is unaware of the exact extent and accuracy of our knowledge. Therefore, an effort should always be made to prevent possible opponents from gaining the ability to accurately assess our precise intelligence capabilities. The extent of security measures employed should depend on the importance of the particular intelligence as compared to the ability and cost of various protection means.

Record of Dissemination.— A record of dissemination is a listing of the recipients of the intelligence. Sometimes records of dissemination are called dissemination lists, tables of distribution, or lists of recipients. Often, producers will include a record of

dissemination with intelligence documents so that recipients of a document can determine what other organizations have copies of the document. Intelligence producers may use their records of dissemination to keep track of documents so that notices of change and updated copies can be sent to holders of the documents.

In theory, records of dissemination maybe used to control intelligence documents for security purposes. In practice, however, records of dissemination are not generally used for security purposes because other administrative procedures have been established to safeguard all classified material, including intelligence.

INTELLIGENCE IN THE OPERATING FORCES

Support to operating forces is the cornerstone of naval intelligence. Because of their mobility and forward deployment and the unique nature of their missions, naval forces have special requirements for intelligence on potential threats in both the maritime and littoral environments. Naval intelligence is designed to support operations at sea, from the sea, and ashore through an organization closely linked with joint and national intelligence centers.

Another aspect of support to operating forces is the Intelligence Preparation of the Battlespace (IPB). This is the systematic and continuous analysis of the adversary, terrain, and weather in the assigned or potential battlespace. It is a significant element in the Commander's Preparation of the Battlespace (CPB) and a key part of the decision-making process. Its goals include understanding the adversary's forces, doctrine, tactics, and probable courses of action, together with the physical and environmental characteristics of the target area.

The IPB identifies gaps in knowledge that require intelligence collection efforts. The IPB is important to all aspects of combat planning. It's not limited to the support of planning, but is a long-term, continuous effort directed against potential adversaries as well. We use the IPB to plan actions and to manage the risk to friendly forces. Risk will always be inherent in military operations, but the IPB seeks to reduce that risk. We assess risk by weighing adversary capabilities and intentions against those of friendly forces and their assigned missions. This risk is then analyzed to determine whether additional information or intelligence could alleviate it. Our management of risk thus depends on a clear understanding of both what is known and what is not known.

NAVY STAFF ORGANIZATION

Intelligence Division

A commander's staff exists to help him/her perform the administrative and operational functions that must be accomplished to achieve the mission. The primary function of the intelligence division of a Navy (N-2, see figure 2-1) or Joint (J-2, see figure 2-2) staff is to ensure the availability of sound intelligent information on the operating area and enemy locations, activities, and capabilities.

The intelligence division of a typical Navy staff is under the supervision of the intelligence officer. This officer is responsible for keeping the fleet commander, among others, informed of intelligence regarding known or potential enemies and operating areas. The intelligence division assists other staff divisions in preparing estimates and plans and in supervising and evaluating the completion of planned actions.

Specific duties of the intelligence division include

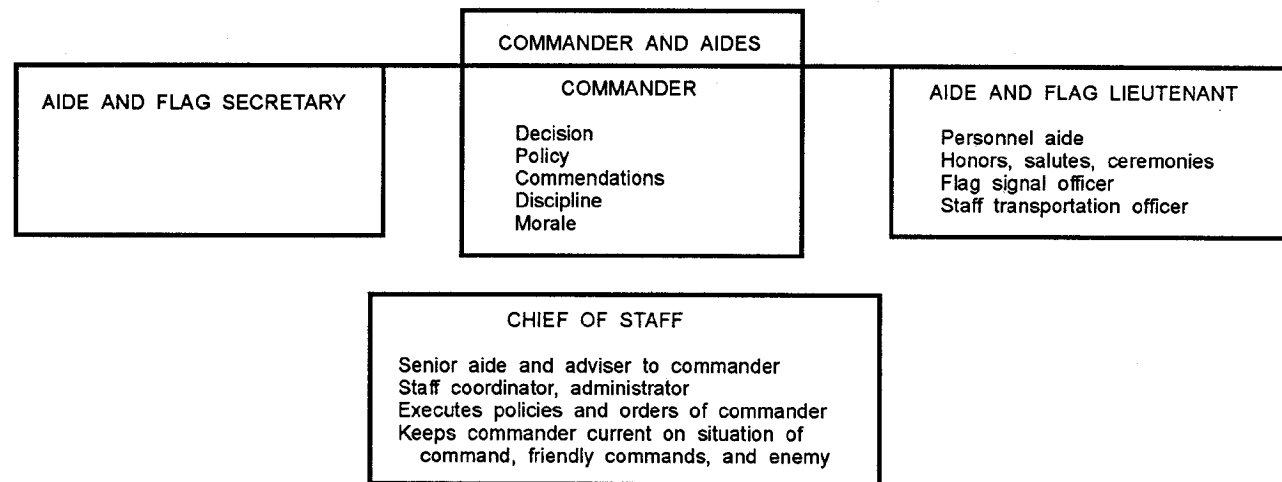

ASSISTANT CHIEFS OF STAFF				
ADMINISTRATION (N-1)	INTELLIGENCE (N-2)	OPERATIONS AND PLANS (N-3)	LOGISTICS (N-4)	COMMUNICATIONS (N-5)
Flag division officer Flag officer official correspondence postal matters classified matter custody files reports control records disposal technical publications library Medical Dental Legal Chaplain Civil affairs Military government Welfare, athletics Disposition of PWs Public affairs including censorship of public affairs releases Data processing	Collection Production Dissemination Administration Security Training	Operations surface air amphibious ASW USW electronic warfare search and rescue Training and readiness Own command data flag plot anchorage bases Plans current future liaison Aerology	Supply Comptrollership Maintenance, repair, salvage Medical and dental services Personnel logistic services Transportation Construction Maintenance and Material Management (3-M)	Rapid communication Communication equipment Communication security Communication intelligence Registered publications Message center

Figure 2-1—Typical Navy staff.

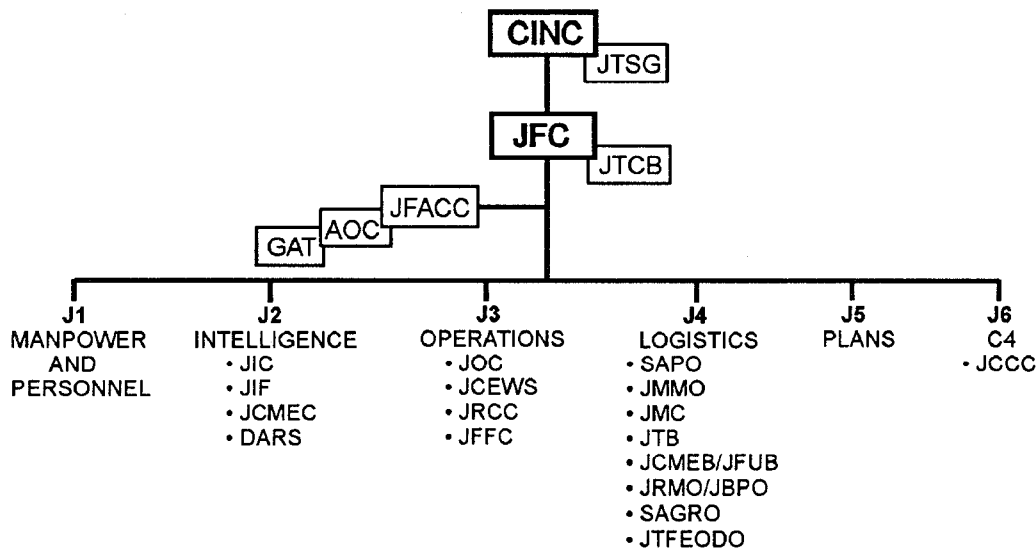

Figure 2-2.—Typical Joint staff

- planning, coordinating, and supervising activities related to collecting, evaluating, and disseminating intelligence about known or potential enemies, or known or potential enemy operating areas (including port, air, and surface targets);
- formulating fleet intelligent studies;
- conducting photographic interpretation;
- providing technical and counterintelligence;
- conducting censorship;
- maintaining a situation plot; and
- providing internal and external security measures.
- Keeping the commanding officer, executive officer, and operations officer informed of intelligence materials held and of requirements for procuring additional material;
- Ensuring that all intelligence material, maps, charts, and publications are on hand as required by current instructions;
- Conducting briefs on a need-to-know basis concerning intelligence information, and routing items of general interest to unit officers;
- Supervising photographic intelligence; and
- Providing a secure stowage for intelligence material as prescribed by *Department of the Navy Information and Personnel Security Program Regulation, OPNAVINST 5510.1*, and other pertinent directives.

The Intelligence Officer

The intelligence officer, who is generally under the direction of the operations officer, is responsible for the collection and dissemination of intelligence. In the discharge of his/her duties, the intelligence officer is responsible for the following:

- Ž Maintaining a suitable classified file of all incoming intelligence matters and becoming thoroughly familiar with its contents;
- Ž Taking advantage of every opportunity to collect and report information of intelligence value, as set forth in various national, fleet, force, and unit intelligence collection plans;

The intelligence officer normally reports to the operations officer in the performance of assigned duties and coordinates all intelligence matters with the operations officer. Assistant intelligence officers, as may be assigned, report to the intelligence officer.

Leading Chief or Division Petty Officer

The individual designated by the division officer as the leading chief or division petty officer will normally be the senior chief petty officer or petty officer in the division. He/she assists the division officer in the administration, supervision, and training of intelligence division personnel.

You will find that intelligence organizations differ somewhat from ship to ship and from station to station. But regardless of the particular organization, your job is to assist the intelligence officer in accomplishing the division's assigned tasks. For every responsibility the intelligence officer has, you have an equal responsibility to assist him/her to the best of your ability.

JOINT INTELLIGENCE CENTERS

A highly successful Navy operational intelligence (OPINTEL) community built around Ocean Surveillance Information System (OSIS) nodes and Fleet Intelligence Centers was established in the early 1970s to focus primarily on the then-Soviet naval threat. At that time, there were limitations on the ability of afloat forces to perform all-source analysis and provide OPINTEL support. This was due in part to the lack of shipboard space, communications limitations, and the lack of automated correlation systems. The OSIS nodes performed the vital service of distilling and integrating the intelligence for the afloat units.

Although organizations and threats have changed, Navy OPINTEL expertise still exists and is properly focused on naval operations support but has made a transition to the Joint Intelligence Centers (JICs). Meanwhile, afloat capabilities have improved such that tactical data processors using greater communications bandwidth allow afloat forces to build dynamic, integrated operations and intelligence pictures.

There now exists a balanced sharing of the fusion and analysis between afloat and ashore elements of naval and joint intelligence. Generally:

- Ashore processing (JIC) should provide information/intelligence for the planning decision-oriented domain, where time and space are expanded and the decisions involve the allocation and movement of forces.
- Afloat processing should provide information/intelligence for the tactical decision domain, where time and space are compressed and decisions involve the release of weapons on target.

One of the major sources of intelligence support for the fleet in any naval operation is the JIC. Each theater will have a designated JIC serving the intelligence needs of all theater elements, including the naval component commander. This support consists of long-term studies and strategic and planning

intelligence for operational commanders concerning their areas of responsibility, tailored specifically to any unique needs they may have.

The theater JIC processes, analyzes, produces, and disseminates intelligence to meet its core responsibilities. Those core functions or responsibilities may include

- theater I&W;
- target folder production;
- current, operational, and technical electronic intelligence;
- political, military, and regional intelligence analysis;
- unconventional threat analysis (including narcotics trafficking, combating terrorism, and counterintelligence);
- general military intelligence and distributed production;
- escape and evasion studies;
- combat intelligence applications (targeting, target materials production, battle damage assessment, cruise missile support, and expeditionary forces support);
- biographical information for consumers in the area who need information on foreign military and political figures;
- imagery exploitation and secondary imagery dissemination.

The JICs receive their information from both the national level and the various operating units in their area of responsibility. Periodically, naval intelligence Reserve units work on various projects, such as beach, port, and transportation studies. They then report their findings to the JICs under the Fleet Project Program, and carry out other projects in coordination with ONI and DIA.

INTELLIGENCE FOR AIR OPERATIONS

Air intelligence is defined as intelligence pertaining to the offensive and defensive capabilities of foreign countries and their vulnerability to air attack. Commanders require air intelligence to plan, train for, and execute operations involving or affected by air power.

Mission of Air Intelligence

Air intelligence is key to the proper employment of air assets. Air power today has tremendous range, speed, mobility flexibility, and striking power. The mission of air intelligence is to provide information that will make possible the most effective use of this power, to direct flights to any part of the world and, once there, to achieve the maximum results.

Air intelligence has both strategic and operational applications. On the strategic side, you must identify information that impacts the commander's decision-making processes and policies. On the operational side, you must also concentrate on indications of probable hostilities without neglecting information on the capabilities and vulnerabilities of a potential enemy.

The mission of operational air intelligence is to

- procure, process, and disseminate information on the actual or potential enemy forces, the area of air operations, and any other information that will assist the air commander in arriving at timely and sound decisions in support of existing plans;
- brief aviation personnel prior to all flights, on the type of flight, objectives, operating areas, targets, flight route, expected air opposition, types of hostile aircraft, surface-to-air missile sites, communication procedures, search and rescue procedures, evasion and escape information, aerology, and any other information considered pertinent to the success of the flight; and
- debrief returned aviation personnel on all aspects of the completed flight, such as hostile ships and aircraft in the area, results of air-to-air and air-to-ground combat, ground installations observed, and troop movements and bomb damage observed.

Carrier Air Operations

The major fighting ship of the fleet is the aircraft carrier. If limited war occurs, the deployed aircraft carrier has the capability to

- maintain control of the air over the fleet and landing forces;
- defend itself against or elude attacks by aircraft, submarines, or missiles;

- support and protect amphibious landings;
- provide close air support to ground troops;
- interdict enemy lines of communications; and
- mount air attacks precisely tailored to the objective.

Information collected by carrier-based aviation personnel through observation and photography covers many components of both operational and strategic intelligence, as follows:

- Enemy aircraft in the area (numbers, types, performance data);
- Air installations and missile sites (location, size and capacity, and possibility of expansion);
- Ports and port facilities;
- Troop movements and ground installation; and
- Ships and ship movements, both naval and merchant.

Strike Warfare

Strike warfare is the destruction or neutralization of enemy targets ashore. The mission is to plan and execute strike warfare missions in support of joint and combined coordinated offensive operations against land targets, including support of contingency operations through effective integration or federation of assigned forces. For detailed information on strike warfare, you are encouraged to consult chapter 4 of *Intelligence Specialist 3 & 2 (U)*, Volume 2, NAVEDTRA 12805, and the *Naval Component Intelligence Tactics, Techniques, and Procedures (NCITTP)* handbook.

Air Patrol Operations

Because of their greater size and range, patrol aircraft, such as the Navy's P-3C, are better equipped than carrier-based aircraft to engage in certain air operations that do not necessarily require great speed. The missions of antisubmarine warfare (detection barriers against submarine and air attack, search and patrol, and shipping surveillance) can be accomplished better by patrol aircraft, which can operate for many hours and at great distances from their bases.

Helicopter Operations

The full potential of helicopter-borne forces can be realized only if accurate and detailed information of enemy dispositions and terrain is available during planning. Required intelligence includes

- location, strength, type, and disposition of enemy ground forces in the objective area, with particular attention to the location of antiaircraft defenses, artillery, and mechanical units;
- location, strength, and type of enemy air forces capable of attacking the helicopter-borne forces;
- enemy reinforcement capability;
- detailed characteristics of the terrain in the objective area, particularly concerning potential helicopter landing zones (HLZ);
- location of suitable approach and retirement routes and their relation to cover and concealment from the enemy;
- landmarks and navigational checkpoints along approach routes and near landing areas;
- detailed weather information on the area of operation; and
- information needed for escape and evasion in the event of a forced landing.

Obstacles to helicopter landings maybe emplaced very quickly. It is essential, therefore, to obtain last-minute confirmation of earlier reports on helicopter landing zones and approach lanes. This proof may be obtained by aerial reconnaissance or by using reconnaissance teams to precede the first wave of the main body.

INTELLIGENCE FOR AMPHIBIOUS OPERATIONS

An amphibious operation is a military operation launched from the sea against a hostile or potentially hostile shore. It is directed by the combatant commander subunified commander, or joint task force (JTF) commander delegated overall responsibility for the operation. An amphibious operation normally requires extensive air participation and is characterized by closely integrated efforts of forces trained, organized, and equipped for different combat functions.

Purpose and Planning

Amphibious operations are conducted to establish a landing force on a hostile shore in order to achieve the following results:

- Prosecute further combat operations;
- Obtain a site for an advanced naval or air base;
- Deny use of an area or facilities to the enemy; and
- Fix and deceive enemy forces, providing opportunities for other combat operations.

The amphibious operation is a complete operation within itself. It includes planning, embarkation of troops and equipment, rehearsals, movement to the objective area, final preparation of the objective, landing of assault troops and accompanying supplies and equipment, and support to the landing force until termination of the amphibious phase of the operation.

Although the majority of intelligence requirements are defined in the planning phase of an amphibious operation, intelligence is a continuous cycle and goes on throughout the entire operation. It is very important to establish requirements early because organic assets needed to satisfy these requirements are lacking within the task force. Early identification of EEIs is critical to allow time for external agencies to be able to address those requirements.

Types of Amphibious Operations

The principal type of amphibious operation is the amphibious assault. Its unique feature is that it involves establishing a force on a hostile or potentially hostile shore. Other types of amphibious operations are as follows:

- **Amphibious withdrawal**— an operation involving the extraction of forces by sea from a hostile or potentially hostile shore.
- **Amphibious demonstration**— an operation conducted to delude the enemy into an unfavorable course of action by a show of force.
- **Amphibious raid**— an operation involving swift incursion into or a temporary occupation of an objective followed by a planned withdrawal. Raids are conducted for such purposes as:
 - Inflicting loss or damage;

- Securing information;
- Creating a diversion;
- Capturing or evacuating individuals and/or material;
- Executing deliberate deception operations; and
- Destroying enemy information-gathering systems to support operations security (OPSEC).

Not all amphibious operations can be included in the four types just mentioned. Forces may be called upon to conduct conventional amphibious operations that may closely parallel one of the four types (for example, noncombatant evacuation operations [NEOs] may closely parallel an amphibious raid). In these situations, the command relationships prescribed for conventional types of amphibious operations are used.

ANTISUBMARINE WARFARE (ASW)

Because of the higher speed and longer underwater range of which submarines are now capable, special attention must be given to tactical ASW, that is, the location and destruction of submarines at sea.

At present, the major weakness of ASW is the initial detection and pinpoint location of submerged submarines. Unless its approximate location is known or suspected, a submerged submarine, or even a snorkeling submarine in a high sea, is practically undetectable.

By definition, location is an intelligence problem. Every possible means must be used to keep track of every enemy submarine from the time it is built or launched. Intelligence on enemy submarines, including strengths, tactics, and locations, is a big part of ASW.

Two closely related systems are used for processing antisubmarine data. The naval intelligence departments process operational intelligence, and the operational departments process operational information. Each system furnishes information to the antisubmarine commander, who must correlate the data in order to estimate the situation as it affects him. The definitions of operational intelligence and operational information as used in ASW are given below:

- **Operational intelligence**— Antisubmarine operational intelligence is knowledge of both enemy and neutral submarines, their operations,

their operating areas, and their supporting facilities. It is knowledge obtained by logical analysis and integration of all available data that is potentially significant to operational planning or operational decisions. Antisubmarine intelligence may be of a standing nature (having a degree of permanence) or of an immediate nature, that is, becoming available during the conduct of operations.

Standing intelligence deals with such matters as the characteristics of submarines, submarine facilities, the probable tactics submarines will use, and the probable area of operations. This intelligence is derived from the analysis of accumulated data gathered from any and all sources.

Immediate intelligence is related to the current activities of enemy submarines, their positions, movements, and intentions. It is obtained during naval operations, usually by contact with the enemy, by operating forces, and by chance observers, such as aircraft, fishermen, and commercial shipping.

- **Operational information**— Antisubmarine operational information is knowledge of the composition, location, movements, characteristics, intentions, and other pertinent data of our own and allied forces, noncombatant shipping, and aircraft.

Intelligence organizations continually send up-to-date intelligence to the various ASW platforms concerning possible submarine locations, their capabilities, limitations, and destinations. The ASW operational forces take this intelligence information and commence to search for the enemy boat. This initial phase of the ASW operation is known as the search phase.

The search phase continues until one of the searching units makes a contact. This initial contact is not yet a submarine classification; it remains a contact until the submarine is classified. Upon making contact, the contacting unit commences classification procedures. In times of international tension, emphasis is on identification, which may involve application of holddown tactics until the submarine is forced to surface and identify itself. Contact made on a submarine during wartime entails immediate classification.

On the basis of information developed concerning them, submarine contacts are classified as certain submarine, probable submarine, possible submarine, or nonsubmarine. The term finally judged to be correct

for the contact depends on the amount of information known about the contact available through the various sensors used by the ASW forces in pursuit.

Once the mission commander makes the classification decision, and reports to the operational commander, any subsequent changes in the classification because of additional tactical information must also be reported. When more than one ASW unit is in contact, the scene of action commander (SAC) coordinates all information from the units in contact and makes the final decision.

When a contact is classified as a possible, probable, or certain submarine, the ASW ship, submarine, or aircraft then makes every effort to gain the advantage and exploit it by attacking until the submarine is destroyed. This final phase of ASW operations is called the attack phase. Complete information on classification and attack methodologies can be found in the *P-3 Tactical Manual (U)*, NWP 55-2-P3, and in *Tactical Airborne Information Document (U) (TACAID) for ASW Aircraft*, NWP 55-2-2.

NAVAL SPECIAL WARFARE (NSW)

NSW encompasses naval operations generally accepted as being nonconventional, in many cases covert or clandestine in character. These operations include the use of specially trained forces assigned to conduct unconventional warfare (UW), psychological operations, beach and coastal reconnaissance, coastal and river interdiction, and certain tactical intelligence collection operations, in addition to those intelligence functions normally retained for planning and conducting special operations in a hostile environment. A Naval Special Warfare Task Group (NSWTG), Task Unit (NSWTU), or SEAL team is typically assigned to the Commander, Amphibious Task Force (CATF), battle group commander, or a numbered fleet commander.

NSW forces perform special operations in support of fleet and joint commanders; however, they become part of the joint structure as soon as a mission is assigned and JTF formed. NSW mission areas applicable to strike warfare are special reconnaissance (I&W, battle damage assessment [BDA]); direct action (standoff or

close combat); laser target designation; beacon emplacement; and combat search and rescue (CSAR.) Deployed SEAL platoons may be assigned to a CATF, a battle group (BG), or an ashore NSW unit.

NSW forces offer division of labor, real-time intelligence, maritime and riverine target specialization, and a naval low-intensity conflict interface. They are limited by available insertion assets, intelligence requirements, geographic location, communications, and the necessity to deconflict SEAL targets from the strike groups.

Intelligence must assist commanders in identifying relevant, clear, and attainable special operations objectives that will further overall objectives. In the process of identifying and nominating military objectives, you should understand the command's responsibilities, the commander's mission and intent, the means available, and the characteristics of the theater or joint operations area. Intelligence should provide the commander with an understanding of an enemy in terms of enemy goals, objectives, strengths, weaknesses, values, and critical vulnerabilities. Once objectives are determined, intelligence must continuously review them to see whether they remain relevant to the commander's intent.

SUMMARY

The objective of this chapter was to acquaint you with the function of intelligence in the operating forces and to familiarize you with the various aspects of intelligence with which you may come into contact.

Intelligence is an ever-changing art, and continuing improvements in technology and methods will contribute to even more advanced data systems and processes than those currently in operation. With the advent of new equipment designs and new warfare techniques, intelligence must change and adapt accordingly to perform its function properly. Therefore some of the concepts and organizations that existed when this chapter was written may have been changed or modified by the time you study this material. You are encouraged to always keep yourself informed on the latest developments in all fields of intelligence.

CHAPTER 3

TECHNICAL ADMINISTRATION

LEARNING OBJECTIVES

Upon completing this chapter you should be able to do the following:

- *Describe the procedures for procuring and stowing supplies used in the intelligence office.*
 - *Identify basic office equipment found in the typical intelligence office and state its primary uses.*
 - *Identify the basic audio-visual equipment found in the typical intelligence office and state its primary uses.*
 - *Explain the procedures for handling office files and records.*
 - *Describe the procedures for properly disposing of files, records, publications, directives, and so forth.*
 - *Discuss the basic requirements for managing the Naval Warfare Publication Library (NWPL).*
 - *Explain the Directives Issuance System and identify the three types of directives.*
 - *Identify the types of naval correspondence used in the intelligence office and the basic formatting requirements of each type.*
 - *Identify the classes and types of naval messages and their basic formatting requirements.*
 - *Explain the security procedures involving the accountability, control, and proper destruction of classified material.*
-

As an IS, you will perform a wide variety of administrative and clerical tasks, such as those listed below:

- Typing, forwarding, routing, and filing correspondence, reports, and directives;
- Maintaining publications;
- Performing duties associated with personnel administration;
- Performing Special Security Officer (SSO) or security manager duties associated with personnel and physical security;
- Operating office and reproduction equipment;
- Operating classified mail rooms;
- Maintaining a Naval Warfare Publication Library;
- Requisitioning supplies; and
- Stowing and disposing of obsolete records.

This chapter is intended to help you to effectively accomplish these administrative functions.

A very important duty area for an IS is the intelligence office. The intelligence office serves a dual purpose:

- Disseminates information to authorized recipients, such as the commanding officer, air group, and staff; and
- Serves as an intelligence information processing facility

In the intelligence office, the IS collects, processes, and forwards a variety of information to other agencies, as directed by higher authority.

There are many factors that make an intelligence office effective: size, type, mission, availability of space, equipment, and personnel; but the most important factor is the initiative, industry, and ingenuity of the intelligence personnel.

The intelligence office should be as comfortable and inviting as circumstances permit. Within the function of disseminating intelligence information, the intelligence office must attempt to present the information so that it can be easily absorbed. Displayed information should be presented in a logical, readable, and neat manner to ensure ease of understanding.

In the following section, we will discuss how to requisition and care for the supplies used in the intelligence office.

PROCURING AND CARING FOR SUPPLIES

Your office job may include keeping necessary supplies on hand, stowing them properly, and distributing them as needed. You need to know what kinds of stationery, blank forms, filing materials, pencils, and other equipment are used in your office; where and how to procure them; and how to take care of them. When you see that your stock of a certain item is becoming low, order it. Do not wait until the supply is exhausted.

REQUISITIONING SUPPLIES

Ordering supplies is not difficult. You will use the Military Standard Requisitioning and Issue Procedures (MILSTRIP) for ordering all materials (except those items listed in chapter 3, section 3022, of *Afloat Supply Procedures*, NAVSUP Publication 485) from the Navy Supply System, other military installations, the Defense Logistics Agency, and the General Services Administration.

Requisitioning is based upon the use of a coded single line item document for each supply transaction.

Depending on the situation, you will use one of the following forms for MILSTRIP requisitions:

- DOD Single Line Item Request System Document (Manual), DD Form 1348;
- Single Line Item Consumption/Requisition Document (Manual), NAVSUP Form 12501;
- DOD Single Line Item Request System Document (Mechanic), DD Form 1348M;
- Non-National Stock Number (NSN) Requisition (4491), NAVSUP Form 1250-21;
- DOD Single Line Item Requisition System Document (Manual-Long Form), DD Form 1348-6.

In this section, we will discuss only the DD 1348 and NAVSUP 1250-1. Refer to NAVSUP Publication 485 for complete instructions and examples of all the forms listed above. You may also refer to the *Coordinated Shipboard Allowance List (COSAL)*, SPCCINST 4441.170, for additional information on supply procedures.

The DD Form 1348 is used by nonautomated ships without card-punch facilities. The form is available in two-, four-, and six-part sets, depending on the requirements of your local supply center. Take all parts of the form to your supply department.

They will finish filling in the form and send you a copy of the completed form along with the item you have requisitioned. Figure 3-1 is an example of DD Form 1348.

If you are operating under manual supply procedures, use a NAVSUP Form 1250-1 (see figure 3-2). Take all parts to your supply department. They will finish filling in the form and send you a copy of the completed form along with the item you have requisitioned.

Future developments include the use of CD-ROM technology to completely automate the requisition and upkeep of supplies.

Check your supplies at regular intervals so you won't be out of something when it is needed. Examine regularly the desks of personnel you support to see that they have the necessary materials. Avoid stockpiling; the supply department normally maintains the stocks you require. An oversupply will be hard to stow and will encourage wasteful habits.

DOC. IDENT. 1	ROUT. IDENT. 2	FSC 3	NIN 4	ADD. USE 5	QUANTITY 6	SERV. REQUISITIONER 7	DATE 8	SERIAL 9	D. SUPPLEMENTARY ADDRESS 10	S. FUND 11	DISTRIBUTION 12	PROJECT 13	PRIOR. TRY 14	REQ. DEL. DATE 15	ADV. STAT 16							
SEND TO:										REQUISITION IS FROM:												
A	B	C	D	E	F	G	H	I	J	K	L	M	N	O	P	Q	R	S	T	U	V	
DD FORM 1348 (6-PT) 1 MAR 74	EDITION OF 1 AUG 61 MAY BE USED UNTIL EXHAUSTED	D	USE TYPEWRITER OR BALL POINT PEN	PRESS HARD	TO ASSURE LEGIBILITY ON ALL COPIES	S/N 0102-LF-501-3490	ISNP0004															

Figure 3-1.—DD Form 1348.

STOWING SUPPLIES

Keep supplies nearly stowed where they will be out of the way and kept in good condition. Closed cabinets are preferable to open shelves because they protect the supplies from dust and damage. Closed cabinets prevent the supplies from becoming disarranged by drafts or by random handling or jostling. They also tend to prevent waste and misuse by making the supplies less accessible to casual passersby.

Keep related items in one place, and keep the most used supplies in the handiest places.

Open only one package of each kind of material. Label the contents of wrapped packages with a colored

pencil on the wrappings. This will prevent personnel from tearing into the packages to find out what they contain.

AVOIDING WASTE

Avoid all forms of wastefulness. All departments are allotted quantities of supplies that are expected to last a given time. If you are wasteful, your office may find itself without needed supplies and with no replenishment in sight for sometime.

OFFICE EQUIPMENT

The use of personal computers, typewriters, photocopiers, and facsimile machines has become an

1. REQ. DATE	2. DEPT. NO.	3. URGY	4. RDD	5. LOCATION	6. SIM	NON-SIM	7. ISSUE DATE	A. REQN. QTY	B. REQN. NO.																																																																		
8. NOUN NAME OR REF SYM	9. FPR	10. APL/AELCID	11. INVQTY	12. NIS	NC	C. OBL AMT	D. POSTED	S/R (REQN O/S)	OPTAR LOG																																																																		
13. UIC	14. WC	15. USN	16. EIC	17. EQUIP COSAL SUPPT'D	YES	NO	E. URG	MART	S/R (ISSUE)																																																																		
18. SC	19. COG	20. MCC	21. FSC	22. NIN	23. ADD	24. QUANTITY	25. UNIT PRICE	26. EXTENDED PRICE	27. FUND																																																																		
29. REMARKS	30. APPROVED BY:	31. RECEIVED BY:	1	2	3	4	5	6	7	8	9	10	11	12	13	14	15	16	17	18	19	20	21	22	23	24	25	26	27	28	29	30	31	32	33	34	35	36	37	38	39	40	41	42	43	44	45	46	47	48	49	50	51	52	53	54	55	56	57	58	59	60	61	62	63	64	65	66	67	68	69	70	71	72	73
DOC IDENT	RTG IDENT	M & S	SVC	UIC	JUL DATE	SERIAL	D E M	S V C	SUPPL ADDRESS	S I G	FUND	DIST	PROJ	PRI	RDD	ADV																																																											

SINGLE LINE ITEM CONSUMPTION/REQUISITION DOCUMENT (MANUAL)
NAVSUP FORM 1250-1 (7 PT) (REV.12/76) S/N 0108-LF-501-2506

Figure 3-2.—NAVSUP Form 1250-1.

integral part of the efficient intelligent office. You should have a basic knowledge of how to give proper, routine care to all of these machines. This does not involve complicated repairs or major fixes; however, you may have to make some minor adjustments to ensure that the equipment operates properly.

You should already be acquainted with the Planned Maintenance Subsystem of the Navy Maintenance and Material Management (3-M) System, since it is discussed thoroughly in *Military Requirements for Petty Officer Third Class*, NAVEDTRA 12044. Therefore, we will not go into detail about the mechanics of the system.

AUTOMATED INFORMATION SYSTEMS (AIS)

Automated information systems include computer hardware and software designed to make the handling of data as simple as possible. The type of systems available will depend on your command as well as the type of job you will be required to do. Types of software include but are not limited to:

- Word processing;
- Database management; and
- Spread sheets.

Other systems designed to accomplish a specific function are also available. For example, the Shipboard Nontactical Automated Data Processing Program II (SNAP II) provides automated supply and financial functions for shipboard use. Of particular interest to you is the Maintenance Data Subsystem (MDS), which provides support to the ship's 3-M System.

We will address AIS extensively in chapter 7 of this manual. We will discuss the creation, transfer, and manipulation of data files, graphics, and databases. We will also discuss scanning text and graphics into data files and the importance of running virus-checking software to protect your systems.

TYPEWRITERS

Although the typewriters in your office may have had little use since the advent of word processing systems, they may still serve as a back-up system. In fact, they must be used in many cases to complete certain nonautomated forms and correspondence. Typewriters range from those with extensive computer electronics and software to the basic electric type. They may be heavy and rugged looking, but they are, in fact, delicate instruments. Treat them properly and give

them daily care. A machine in first-class condition is easier to operate and will turn out better quality work.

If operating instructions for your typewriter are available, they will help you identify its parts and give you additional information about its care. If you believe your typewriter needs to be oiled or repaired, turn it over to a typewriter mechanic.

Examine your typing at the beginning of each day to see if it contains any faults. If you find a fault and it persists after you have taken corrective action, call your service representative. When you are located in a remote area (base or ship) and are not able to have your typewriter repaired, continue to use it as long as the type is readable. When the type becomes unreadable, type your documents on any available typewriter. As soon as possible, have your typewriter repaired or exchanged.

MICROFICHE

A microfiche is a sheet of microfilm containing multiple microimages in a grid pattern and a header information area that can be read without magnification. Most microfiche readers have a variety of lenses that provide varying degrees of magnification. Typical uses for microfiche are:

- Service records;
- Technical publications;
- Library indexes; and
- Supply listings.

Readers

If you are involved in the purchase of microfiche reader equipment, some things to consider are:

- Microfilm flexibility;
- Frequency of use;
- Portability; and
- Light conditions.

To evaluate all subjective factors properly, you should if possible, try your own microfiche on any prospective equipment.

Reader-Printer

The reader-printer provides a fast, simple method of viewing microfiche records, as well as making a

permanent copy in seconds. Since most reader-printers have different operating instructions and designs, we will not cover their care and operation. In all cases, you should familiarize yourself with the appropriate operating procedures established by your command.

COPY MACHINES

Copy machines are used throughout the Navy. Letters, drawings, and forms can be reproduced in minutes, and with some models, in seconds. Because there are so many of these machines, all differing slightly, it is impractical to describe any of them here. If you have a machine of this type in your office, you should also have the appropriate operating manual to study.

Control of Copy Machines

A potential problem that concerns everyone in your office is usage control of copy machines. Increased availability of these machines and their widespread use have created security problems and increased operating costs. These machines permit quick, easy reproduction of classified material, leave latent impressions on reproduction equipment, and create excessive waste material that can contribute to the compromise of classified information. A few of the many misuses and abuses that contribute to high operating cost are:

- Copying blank forms or publications that are available from the stockroom;
- Making more copies than are needed on the mere possibility that extras may be required; and
- Using a copier for long runs that should have been done by a print shop.
- Controls should be established to prevent unnecessary costs and to prevent security abuses in the use of these fast-copy machines.

FACSIMILE MACHINES (FAX)

A facsimile, or fax, machine is an electronic device that allows correspondence and graphics to be transmitted over a telephone or other communication line. It has significantly cut down on the amount of time spent waiting for information to be either mailed or hand delivered.

Fax machines can be used over both secure and nonsecure telephone lines. Therefore, before you declare a line or link to be secure, you must take the

proper care and consult the command security manager to ensure that all the requirements have been satisfied.

Fax machines, depending on the model, can have a wide variety of options and features. These options and features allow you to choose exactly how a document will be transmitted, received, or copied.

AUDIO-VISUAL PROJECTION EQUIPMENT

Intelligence briefings in many instances use audio-visual equipment to support the brief. On some occasions, you may be required to set up and possibly operate such equipment for the briefing officer. You should therefore be familiar with the general operating instructions and also the preventive maintenance of such equipment that your command has available.

OVERHEAD PROJECTOR

The overhead projector shown in figure 3-3 is used to project an image from a transparency. A desirable

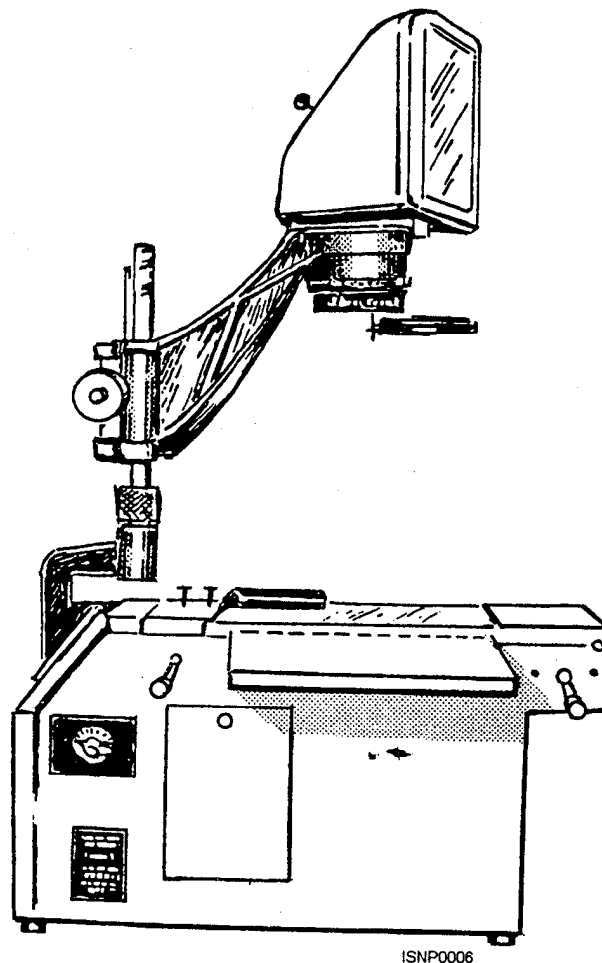

Figure 3-3.—Overhead projector

feature of the overhead projector is that it can be used in a room without turning off the lights. Additionally, the size of the transparency is large enough to allow the instructor or briefer to work directly on it as he or she is talking. By writing on clear acetate with a grease pencil, the instructor can create a transparency while instructing the class.

The overhead projector can be set up on either side of the screen. For classroom use, the projector is normally located in front of the screen, allowing the instructor to operate it while instructing the class. For command briefings, the projector is usually placed behind the screen so that it offers no interference to the audience.

Placement of the projector requires the operator to consider the best possible arrangement for each situation. Several points to keep in mind areas follows:

- Place the projector on a table or stand at such an angle that the projected image will be nearly a perfect rectangle. Projectors not properly placed will result in an image that is keystoned (wedge-shaped).
- Make every effort to ensure that each member of the audience will be able to see all of the projected image. However, keep in mind that the farther you move the projector from the screen, the less intense the projected image will be.
- Projected images should be viewed without having to shift the eyes over too wide a range. Seating the audience at a distance no closer than twice the width of the image will take care of this requirement.

The location of the projector in relation to the screen will also affect the manner in which the transparencies are placed on the device. The bottoms of the transparencies are always placed toward the screen. Front projection, where the projector is located on the audience side of the screen, requires the transparencies to be placed so that they are readable to the operator. Rear projection, where the projector is located behind the screen, requires the transparencies to be placed face down so that they are unreadable to the operator. Operation of this projector is simple. It involves nothing more than turning on the projection lamp, focusing the image, and positioning the image on the screen.

SLIDE PROJECTORS

Briefings that are formal, rather than operational, and use graphics that may not be changed rapidly, may use 35mm slides to project images. Since the time and expense involved in preparing 35mm slides are considerable, 35mm slides are seldom used in tactical briefings. Slides may be most helpful in recognition training and formal briefings where size of the graphic materials must be considered. The slides may be black and white or color, either negatives or film positives, depending upon the information being presented and the requirements of the briefer.

Slide projectors (fig. 3-4) in use today are available in a wide range of sizes and models. The design of the projector, with the slide tray on top, ensures jam-proof operation. Even though a bent or broken slide may "hang up" in the gate, the slide tray can always be lifted off and the defective slide removed.

The forward and reverse buttons located on the side of the projector control the direction of movement of the slide tray. Momentarily pressing the forward or reverse button changes the slides in either direction at any desired time interval.

The device also can be completely remote controlled. The remote control unit has both FOR (forward) and REV (reverse) buttons for controlling the slide tray and a focusing lever for power-focusing the lens. Momentarily pushing the focus lever forward or

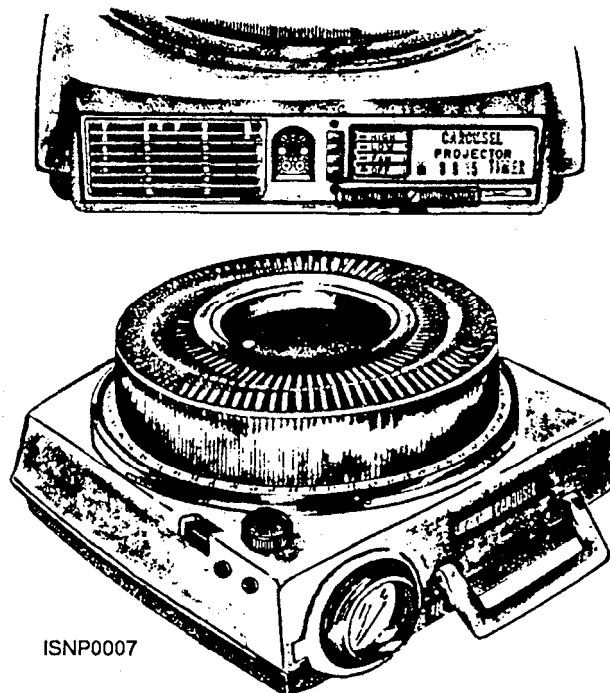

Figure 3-4.—Slide projector.

backward causes the projection lens to move forward or backward, respectively, to adjust focus.

VIDEO CASSETTE RECORDER (VCR)

Whether you are attached to a ship, squadron, or Joint Intelligence Center, you will be hard pressed to find an intelligence office without its own VCR. VCRs are especially useful in “red-time” situations, such as Incidents at Sea or any in-flight confrontation. Consider for example the incident involving USS *John F. Kennedy* -embarked F- 14s and two Libyan MiGs. Video tape recordings of the event proved crucial in the justification of the shoot-down of the MiGs. Video also allowed for expeditious dissemination of the tapes to the theater- and national-level commanders.

The VCR is also an excellent briefing and training aid. There are many different makes and models used in the Navy today, but once you understand the operation of one VCR, you will have little or no difficulty with any others. Each has its own distinct characteristics and advantages, but all are similar in operating principle. Consult your user’s manual for specific instructions in operating your VCR.

For VCRs, preventive maintenance is of the utmost importance. The usefulness of the equipment depends upon its being ready to operate at top efficiency when needed. Keep all recording components clean at all times. Also keep all exposed surfaces free of dust, dirt, and oil vapor deposits. Be sure that all surfaces that come in contact with the film are kept clean.

FILES

One of your frequent tasks will be to file correspondence completed forms, reports, and so on. Constant changes in intelligence office personnel because of transfers, leave, and discharges create a greater than usual need for a reliable, easy to use, single subject classification system. The present standard Navy-wide system fills that need. A person who knows the subject filing system of one ship or station can operate that of another with little decrease in efficiency. This does not mean that each office has the same number of file folders. Rather, it ensures that a standard system is used in assigning subject codes (numbers) and in designating the various types of naval activities, that all general files have the same basic arrangement, and that certain sets of files are kept by all activities.

Details of file arrangement within any intelligence activity depend upon the mission of the activity and on the volume of its official correspondence. There is no

limit to the possible expansion under the standard subject numbering system, yet the system is equally adaptable to the needs of small offices. Files of the components of the Navy Department, or a large systems command for instance, occupy hundreds of cabinets; those of a small ship or station may be kept in two or three. Yet, the same general headings are used for both. The difference in size lies in the number of the subdivisions under each major group.

Department of the Navy Records Management Program, SECNAVINST 5210.8, is the directive that assigns responsibility for establishing, maintaining, and disposing of official subject and other specialized records. *Department of the Navy Standard Subject Identification Codes*, SECNAVINST 5210.11, sets forth the Navy standard file maintenance procedures. *Navy and Marine Corps Records Disposition Manual*, SECNAVINST 5212.5, provides standards and procedures for disposing of records.

STANDARD SUBJECT IDENTIFICATION CODES (SSIC)

The Standard Subject Identification Codes, contained in SECNAVINST 5210.11, provide the basic classification structure for identifying and filing records. They cover most subjects found in general correspondence and other subject files and reflect the functions and major organizational components of the Navy. These same numbers are used for numbering other naval documents, such as reports and forms, directives, and so forth, by subject category. They also provide the basis for a single coordinated Navy-wide subject numbering system.

Numerical Subject Groups

There are 14 major numerical subject groups under the Navy’s standard numerical table. Each group is identified by a four- or five-digit numeric code as follows:

- **1000 Series**— Military Personnel;
- **2000 Series**— Telecommunications;
- **3000 Series**— Operations and Readiness;
- **4000 Series**— Logistics;
- **5000 Series**— General Administration and Management;
- **6000 Series**— Medicine and Dentistry;

- **7000 Series**— Financid Management;
- **8000 Series**— Ordnance Material;
- **9000 Series**— Ships Design and Material;
- **10000 Series**— General Material;
- **11000 Series**— Facilities Ashore;
- **12000 Series**— Civilian Personnel; and
- **13000 Series**— Aeronautical and Astronautical Material.

These major groups are subdivided into primary, secondary, and sometimes tertiary (third level) breakdowns. Primary subjects are designated by the last three digits (the hundreds group) of the code number, secondary subjects by the last two digits, and tertiary breaks by the final digit. For example:

3000 Operations and Readiness
 3800 General Intelligence
 3820 Intelligence Collection
 3821 Human
 3822 Photographic
 3860 Joint and Combined Intelligence
 3880 Intelligence Support Functions

Some of the smaller subject groups are not subdivided below the primary breakdown, whereas larger groups may have secondary and tertiary divisions, as needed.

Construction of SSICs

Refer to section 2 of SECNAVINST 5210.11 for the proper guidance in assigning arranging files, and, if necessary, subdividing SSICs.

TRACKING THE MATERIAL

Unless you have a system to keep track of material that has been removed from your files and the name of the person who withdrew it, your files may be lost or misplaced. You will appreciate the value of a good check-out system when your commanding officer asks for a specific piece of correspondence or a publication, and you cannot locate it due to improper checkout procedures. You may wish to use the procedure described below if your office currently has no check-out system.

When a publication or piece of correspondence is removed from your office, enter data identifying the material (identification code, subject, and date), the name and location of the person borrowing the material, and the date it is borrowed on a File Out Card, NAVEXOS 4178, as shown in figure 3-5. Place this 8- x 10 1/2-inch pink cardboard form into the file from which the material was removed. For checking out publications, place the File Out Card in a ready and accessible location. When the borrower returns the material, cross the borrower's name off the card, return the material to its proper place, and keep the File Out Card handy until you need it again.

Periodically, make a check of your File Out Cards to determine if correspondence or a particular publication has been checked out for an unreasonable period of time. This check may help avoid loss or misplacement of the material and possibly save you considerable embarrassment when you need to find a particular piece of correspondence or publication in a hurry.

RECORDS DISPOSAL

The contents of your files are of such significance that Congress has passed laws governing their disposition and fixing penalties for their unauthorized destruction. These laws apply to unclassified matter as well as to classified matter.

Take all tasks connected with files, including their disposal, seriously. Since you maybe responsible for the work of juniors, you may also be directly involved in the proper disposed of files that have served their purpose.

Do not simply avoid decisions to save, or not to save, all of your files. No matter how firmly you believe that disposing of a file today will mean someone will need it tomorrow, you must make a decision. You cannot continue holding files simply because someone "might" need them. If you are in doubt about disposing of certain records, avoid taking it upon yourself to either retain or dispose of them. Before you reach a decision where doubt exists, consult your superiors to decide what course of action you should take.

The *Navy and Marine Corps Records Disposition Manual*, SECNAVINST 5212.5, spells out the retention period of official files and whether they must be destroyed or forwarded to a Federal Records Center (FRC), National Archives and Records Administration (NARA), or other government agency at the end of their retention period.

DEFINING RECORDS

Your files may contain material that is not considered to be official record material. The Records Disposal Act of 1943 defines government records as "All documentary material, including books, papers, maps, and photographs, made or received by an agency of the U.S. Government in connection with the transaction of public business and appropriate for preservation." Pamphlets, books, extra copies of letters, directives, and so forth, sometimes take up space because nobody made a decision to dispose of them. Whether the materials in your files are official or unofficial, you must dispose of them at regular, specified periods. Do not allow them to remain in your files longer than necessary.

Standard Organization and Regulations of the U.S. Navy, OPNAVINST 3120.32, defines official correspondence as all written material, documents, publications, charts, messages, and so forth, addressed to or sent from a command. These regulations also prohibit persons having custody, possession, or control of official correspondence, forms, or records knowingly to deliver them or reveal their contents to any person not authorized to receive them. Nor may they sell, barter, or trade official correspondence for monetary gain or other consideration.

Nonrecord material, then, may be defined as any material that serves no documentary or record purpose. In other words, it is material that is not needed except for a limited time. Within this category are such things as rough drafts; extra copies of letters kept for convenience of reference or for tickler purposes; some forms of publications received from other than government agencies and commercial firms (catalogs, trade journals); items of only temporary value, which serve no purpose once action is completed; and other reproduction materials.

It isn't always easy to draw a neat distinction between record and nonrecord material and apply a hard-and-fast rule to each item. Each should be matched with a retention standard from SECNAVINST 5212.5 and regularly disposed of by destruction or transferred to a records center. On rare occasions, you may decide that because of some special circumstance, some items normally scheduled for destruction should be retained longer or indefinitely. In such cases, you should transfer the items to a records center for further retention rather than destroying them. But if you are as familiar with the business of your office as you should be, you won't have much trouble in applying the right

disposed provision to the records as they accumulate. Normally, you should dispose of records promptly, as scheduled.

METHODS OF DISPOSITION

The two official methods for disposed of records are:

- Local destruction; or
- Transfer to a FRC, NARA, or other government agency for later destruction, or, if the materials have permanent value, for eventual preservation.

Destruction

Most unclassified records are destroyed locally at the end of their retention periods. Large quantities of unclassified matter may be sold for wastepaper or scrapped. Classified material must be destroyed by burning or other authorized method as outlined in Chapter 13 of the *Department of the Navy Information Security Program Regulation*, OPNAVINST 5510.1 (the Security Manual).

When a state of war exists or hostile action is imminent, a commander may destroy records as an emergency measure. The commander must, however, inform the Chief of Naval Operations that the records have been destroyed. If you are at sea, your unclassified and classified records should be destroyed by burning or shredding, or in an emergency, by jettisoning.

At ashore activities, unclassified records may be scrapped or sold as wastepaper provided the records are either treated to destroy word content (by shredding), or by inserting a contract clause that prohibits the resale or use of the records or documents.

Transfer

Few records are actually transferred for preservation. Those records that have a retention value are transferred to the appropriate records center, unless permission for an exception is granted by SECNAVINST 5212.5.

A Records Transmittal and Receipt form (SF 135) is used to forward retention material to the appropriate records center. One copy of this form is returned to your activity by the record center as acknowledgement of receipt. This copy bears a record center shipment number, which you use when requesting service on transferred records.

Preservation

Indefinite or permanent retention of official records is known as *preservation*. This does not include those records retained at the local level, but is composed of all official records retained at an authorized Federal records center.

Federal law makes it mandatory that, except in extenuating circumstances, records scheduled for destruction must be destroyed. This doesn't mean, however, that every item must be disposed of on THE DAY authorized for destruction. Individual commands may set up any destruction program they wish, such as once every 3 months, semiannually, or annually. What the law intends is that records no longer having value must not take up valuable space over long periods of time. This is especially important aboard ship where every square foot of space has an allotted purpose. Remember, though, you must not destroy records before their scheduled destruction date, except in case of emergency.

REVIEWING

SECNAVINST 5212.5 specifies whether files are to be retained, destroyed, or retired to a records center. Using that instruction as your guide, you will be able to alert the appropriate reviewing officer as to the disposition, retention, or destruction of the material in your files.

One way to ensure that records are disposed of within a reasonable time of the scheduled disposed date is to show the retention periods or disposed date on the file label. Then at intervals, check the files to see what material should be removed for destruction, retention, or transfer.

One word of caution: Even though a disposition date may have passed, do not dispose of material on which action is pending.

Forward records designated in disposed instructions for transfer to a records center as scheduled or earlier. Transfer records designated for permanent or indefinite retention, and records for which you cannot find a disposed authority when they are of no further value to your activity.

PUBLICATIONS AND DIRECTIVES

Much of the efficiency of any Navy office depends upon the currency of its official publications and directives, their accessibility, and how well the people in the office know how to use them.

Another of your routine IS duties will be to handle, correct, and use official publications and directives. You will be expected to identify various publications by title and appearance and to have a general idea of their content and associated procedures. You should stow properly and be able to produce on request all publications issued to your office. If your office checks out publications, you should have a system that allows you to locate any publication at any time. If a publication is classified or registered, follow the instructions outlined in OPNAVINST 5510.1 (the Security Manual) for its handling.

Changes and corrections to publications and directives are made by inserting new pages, removing obsolete pages, or making pen-and-ink changes in the existing book. A publication that is not up-to-date, or one that has been changed incorrectly, may be worse than useless because it can give wrong directions.

When a list of effective pages is included with a change, check all pages of the publication or directive against the checklist to determine if your publication is current.

You will use various publications and directives increasingly as you learn your job. They are the references to which you will turn for information about correct procedures. In any billet, you will need the answers to numerous questions. You cannot possibly remember all these answers, and, in fact, you should *not* try to do so. Instead, you should know *where* to locate them. The better you know your official publications and directives, the quicker you will be able to find what you need.

ORDERING PROCEDURES

As we discussed in chapter 1, you should consult the *Naval Intelligence Products Register* (NIPR), produced through the Office of Naval Intelligence, for proper guidance in ordering publications. You may have to refer to other publications from the Defense Intelligence Agency (DIA) for additional information. Usually, these pubs are controlled through the use of a DIA account number.

INVENTORY PROCEDURES

Inventory procedures are dictated by the types of material that your command holds. OPNAVINST 5510.1 (Security Manual) provides complete information on inventory requirements for the levels of classified material you hold. The type of material held dictates how often an inventory must be done.

Inventories of nonclassified publications and directives depend on the type of operations in which you are involved. For example, if your ship or unit is preparing for a deployment, you will be required to hold certain pubs and directives that pertain to the region or theater in which you will be operating. In this case, you should conduct an inventory, determine your deficiencies, and order the necessary materials.

NAVAL WARFARE PUBLICATION LIBRARY (NWPL)

The NWPL is the central control point for the administration and maintenance of tactical warfare publications. Responsibility for the management of the NWPL is normally assigned to an officer, a senior petty officer, or a civilian as a collateral duty. As an IS, you could be assigned the duties of the NWPL Publications Clerk. In a very small unit, you *might* also be custodian. In either case, you will need to meet the following basic requirements:

- Ensure that the required allowance of publications is on board and readily available for use ;
- Maintain the publications correctly and keep them up to date; and
- Handle classified publications according to applicable security directives.

To ensure that these requirements are met, use the current allowance list and status list to verify that your unit has the necessary naval warfare publications. *U.S. Navy Distribution Procedures for COMTAC and Joint Doctrine Publications*, OPNAVINST 5605.19, provides guidance on required allowance and publication lists, changes and instructions for procurement, and allowance list changes.

NWP FORMAT

NWP 1-01, *The Naval Warfare Publication System*, defines the organization and procedures governing publications that contain naval and Navy service-specific doctrine and tactics, techniques, and procedures (TTP) for use by the U.S. Navy and U.S. Marine Corps. It defines relationships among commands and programs involved in tactical development, assigns responsibilities for developing and maintaining tactical and doctrinal publications, and contains guidance for maintaining the tactical library. NWP 1-01 also addresses joint doctrine and joint TTP (JTTP) and those allied publications (APs) used by U.S. naval forces.

This document provides guidance on doctrine and TTP development through the following stages:

- Project proposal;
- Proposal validation;
- Project development;
- Initial and final drafts;
- Test publications and evaluation;
- Final approval; and
- Maintenance.

NWP 1-01 delineates staffing and coordination requirements for NWPL maintenance.

BINDERS

NWPs are normally bound in hinged, translucent plastic binders and assembled with screw-post fasteners. The title pages are color-coded by security classification:

- Blue indicates Unclassified;
- Yellow indicates Confidential;
- Red indicates Secret; and
- Pink indicates Top Secret.

APs normally have white binders or title pages, regardless of classification. Commands may rebind NWPs to suit individual needs, provided security and accountability requirements are met.

YOUR WORK IN THE NWPL

The tasks listed below are the responsibility of the custodian. However, you will probably perform most of them to one extent or another. Whatever your unit's size or mission, you should use the resources available (such as computer databases, OPNAV forms, hand-written cards) to structure the library's records to meet your unit's specific needs. When a tactical warfare publication arrives on board, you should

- conduct a page check of the publication(s) received. If the check reveals an incomplete publication, submit a report as directed by NWP 1-01 and order a replacement copy (or photocopy/print replacement pages);
- prepare an NWPL Catalog Card, OPNAV Form 5070/1 1 (fig. 3-6), for the custody record tile or update the equivalent records;

- update the inventory (see figure 3-7 for an example);
- apply any stamps or other special markings required by the command; and
- route a publication notice to all interested personnel.

When you issue a publication for subcustody, obtain the signature of the recipient on the catalog card. Each time the publication is returned to the NWPL sign the catalog card in the presence of the person returning it. If the publications are returned to the NWPL for destruction, you may also use the catalog card for the destruction record. When you use the catalog card as a record for security purpose retain it as required by OPNAVINST 5510.1 (Security Manual).

ENTRY OF CHANGES

When you receive changes or corrections (printed or message), conduct a page check to ensure that the change or correction is complete. If your check reveals an incomplete change or correction, submit a report as required by NWP 1-01 and order a replacement copy, photocopy, or a print from a CD-ROM.

For each publication held in the NWPL, you should

- enter the change when it becomes effective; and
- annotate the change in all appropriate records.

If a subcustodian holds the affected publication, you may either recall it and enter the change, or have

the subcustodian enter the change. You may use OPNAV 5070/12 to record entry of changes.

INVENTORIES

You, or the custodian, must conduct an inventory periodically to account for all NWP's classified Secret and above. Treat Confidential materials according to your unit's specific requirements. These inventories are required, at a minimum, annually and upon relief of the commanding officer. When you have finished an inventory, send a report to your commanding officer. You can generate these reports easily by using a computer database program. A sample inventory is provided in figure 3-7.

Whenever the NWPL custodian is relieved, an inventory of all classified publications assigned to his or her custody must be conducted. When the inventory is complete, send a report to your commanding officer. There is no requirement to inventory unclassified publications.

DIRECTIVES ISSUANCE SYSTEM

The day-to-day operation of the Navy depends on information distributed through documents known as *directives*. Directives can be used for any of the following purposes:

- To prescribe or establish policy, organization, conduct, methods, or procedures;

SHORT TITLE	LONG TITLE	CLASS	ALLOWANCE (PRINTED COPY OR CD-ROM SET)	ONBOARD	LOCATION	SUBCUSTODY OR HOLDER	REMARKS	CHANGE STATUS
NWP 1-01	The Naval Warfare Publication System	U	2	1	1. NWPL		Replacement copy ordered	Through I/C 0/3
NWP 3-01.01 (Rev. B)	Antiair Warfare Commanders Manual	C	1	1 paper	1. Ops	Subcustody LT Jones		Change 2
NWP 3-03.32	F/A-18 Tactical Manual	C	2	2	1. Ops 2. NWPL	Subcustody LCDR Thomas		Change 4 through UC 4/5 Change 5 pending
NTIC SERIES B SEP 94 ISSUE	NTIC Series B CD-ROM	S	2 sets of 4 disks each	2 sets of 4 disks each	1. NWPL 2. CIC	Holder LT Jones	2 DISKS UNCLASS 1 DISK CONF 1 DISK SECRET (S-0123-94)	
NWP 3-03.01	Antiair Warfare	S	0	1	NWPL		Locally produced in excess of allowance. (S-034-92)	Change 1

ISNP000T

Figure 3-7.—Sample inventory sheet.

- To require action or set forth information essential to the effective administration or operation of activities concerned; or
- To issue authority or information formally.

The Department of the Navy Directives Issuance System, SECNAVINST 5215.1, provides a standard method of issuing directives by all activities in the Navy. The system contains two parts and two tables:

Part I— Definitions, Criteria, and Responsibilities

Part II— Preparation and Maintenance of Directives

Table 1— Preparation of Letter-Type Directives

Table 2— Preparation of Special-Type Directives

TYPES OF DIRECTIVES

Directives can be divided into three basic types: INSTRUCTIONS, NOTICES, and CHANGE TRANSMITTALS.

Instructions

Instructions are directives that contain authority or information that either requires continuing action or is used continually for reference purposes. An instruction that has not been revised within 7 years from the date it was issued must be either revised or canceled, unless directions indicate otherwise. Extensions of 1 year for required revision or cancellation maybe authorized by appropriate authority, as indicated below:

- The first extension may be approved by the issuing authority.
- The second extension, except for SECNAV and OPNAV instructions, must have the approval of the next higher echelon. No more than two extensions will probably ever be necessary. Joint interservice instructions and publication-type directives are excluded from the 7-year revision or cancellation requirement. Regardless of the age of an instruction, addressees must not consider the instruction canceled unless they receive a positive notification of cancellation.

Notices

Notices are directives of a one-time nature, or ones that contain information or action for a brief time only. A notice usually remains in effect for less than

6 months, but may remain in effect for up to 1 year. A notice has a self-cancellation provision. The cancellation date is always stated. When the exact length of time a notice is to remain in effect cannot be determined at the time of issuance, the specific date for record purposes is set far enough in the future to allow all necessary use of the notice. Reports and procedures covered in a notice are considered canceled when the notice is canceled, unless requirements have been issued in another document.

Change Transmittals

Change transmittals are used to transmit changes to instructions and, under special circumstances, to notices. Each transmittal describes the nature of the change it transmits and gives directions for making the change.

The directives issuance system contains the standard procedures and formats used to issue policy, procedural, and informational releases in the Department of the Navy.

In general, a document is issued in the directives issuance system when it does one or more of the following:

- Regulates, or is essential to, effective administration;
- Establishes policy;
- Delegates authority or assigns responsibility;
- Establishes an organizational structure;
- Assigns a mission, function, or task;
- Initiates or governs a course of action or conduct;
- Establishes a procedure, technique, standard, guide, or method of performing a duty, function, or operation;
- Establishes a reporting requirement;
- Changes, supersedes, or cancels another directive.

With certain exceptions, other issuances not falling within the scope of the above criteria maybe issued in the directives system to obtain quick and controlled dissemination. These may include

- requests for comments, approval, or information;

- directions for routinely carrying out established operations, such as matters on personnel actions or special shipments of material; and
- informative announcements, such as education or promotion opportunities, recreational activities, work improvement plans, suggestions for building morale, or changes in office locations or telephone extensions.

There are two exceptions: required and operational. Required exceptions are Navy Regulations, Top Secret documents, and Communications Security (COMSEC) publications. Operational exceptions include operations plans and orders, technical and regulatory manuals and publications, and their changes.

REQUISITIONING DIRECTIVES

If you need additional or replacement copies of directives, excluding notices, requisition them from the stocking point shown on each directive. Directives formerly stocked at the Naval Publications and Forms Center, Philadelphia, are now provided by the Aviation Supply Office, Philadelphia. To requisition them, use a computer-based program and submit your requests via a modem. Order all notices and those instructions not stocked at the Aviation Supply Office directly from the originator(s) or the stocking location listed on the signature page of the notice or instruction.

DISPOSITION OF DIRECTIVES

Each naval activity maintains directives only during the period of their effectiveness. You may destroy canceled directives, regardless of their classification, without notifying the originating office.

CORRESPONDENCE

Official correspondence in the Navy includes letters, endorsements to letters, memorandums, point papers, and messages. The intelligence office uses all types of correspondence to disseminate the information it produces. For detailed information on correspondence, refer to the *Department of the Navy Correspondence Manual*, SECNAVINST 5216.5. You should always consult this manual when you prepare any type of correspondence to ensure that you are using the proper format.

CLASSIFICATION AND SPECIAL MARKINGS

If your correspondent is classified or designated "For Official Use Only," you must follow the format requirements of chapter 9 of OPNAVINST 5510.1 (Security Manual). By ensuring that your correspondence is correctly formatted and cross-checked with the Security Manual, you will save endless man-hours and processing time. Refer to figure 3-8 for an example of a classified letter.

NAVAL LETTER

As an Intelligence Specialist, you must be able to type an official letter correctly and neatly. Occasionally, you will be required to type an official letter in the intelligence office for the commanding officer's or his or her representative's signature.

Instructions for typing naval letters are very precise to ensure uniform and rapid handling. Follow them to the last detail. Your own way of doing a particular piece of correspondence may seem better, but it will only cause problems in the long run. Take pride in what you do, and do it correctly. Figures 3-9 and 3-10 show an unclassified naval letter.

Assembling a Letter

Arrange the correspondence file that accompanies the letter to be signed according to the instructions of the signing official.

If you assemble the pages of the letter in natural order, tab the signature page to facilitate signing.

Endorsement

An endorsement is a brief form of naval correspondent that an official uses either to comment on or forward a letter that is transmitted via him or her before it reaches its destination or to redirect a misaddressed letter.

An endorsement is most effectively used for transmitting correspondence through the chain of command. It becomes part of the basic letter to which it is appended and is not subsequently treated apart from the letter. Refer to SECNAVINST 5216.5 (Correspondence Manual) for guidance on endorsement types and formats.



SECRET

DEPARTMENT OF THE NAVY
OFFICE OF THE CHIEF OF NAVAL OPERATIONS
WASHINGTON, DC 20350

1
2
IN REPLY REFER TO
5216
Ser 009D/SXXXXXX
JUN 29 1995

1
2
1
2
1
2

SECRET

From: Chief of Naval Operations
To: Commander in Chief, U.S. Naval Forces, Europe
Subj: CLASSIFICATION MARKINGS (U)

1. (S) When typing a classified letter, follow this model.
2. (S) When typing an unclassified letter that has a classified enclosure, only these three steps are necessary. First, type a statement such as the following above the from line:

CONFIDENTIAL--Unclassified upon removal of enclosure (1)

Second, show whether the title of the enclosure is classified or not when citing the document in the enclosure block:

Encl: (1) Listing of Deployed Ships (U)

Third, stamp the enclosure's classification in the center of the top and bottom margins of the letter.

3. (U) When typing a letter that is For Official Use Only, type "FOR OFFICIAL USE ONLY" above the from block at the left margin and near the bottom right margin. Also type those words at the upper left and lower right on the back of the last page.

4. (C) See OPNAVINST 5510.1 (series) and Information Security Newsletters for more on the classification markings introduced in paragraphs 1 and 2.

1
2
3
4

T. A. CLARK
By direction

CLASSIFIED FOR ILLUSTRATION ONLY

Classified by _____
Declassify on _____

SECRET

ISNP0010

Figure 3-8.—Format of a classified naval letter.



1
 2
 3
4 *DEPARTMENT OF THE NAVY
 *Name of Activity
 *Address

1
2

SSIC
 Code/*Serial
 *Date

1
2 From: Title of activity head, name of activity, location when
 needed
 To: Title of activity head, name of activity, location when
 needed (Code)
 Via: (1) Title of activity head, name of activity, location
 when needed (not numbered if only one)
 (2) Pattern of (1) repeated for next endorser
 1
2 Subj: NORMAL WORD ORDER, ALL LETTERS CAPITALIZED
 1
2 Ref: (a) Earlier communication that bears directly on subject
 at hand
 1
2 Encl: (1) Material enclosed with letter identified in same way
 as reference, single enclosure numbered
 (2) Notation added for material sent separately (sep cover)

1
2 1. This example shows all the elements that might appear on the
 original of a one-page standard letter.

2. If you omit the date when you type the letter, start the from
 block on the fourth line below the code/serial to allow for an
 oversized date stamp.

3. Other full-page examples in this chapter and later ones show
 the spacing to follow for correspondence that variously omits
 via, reference, and enclosure blocks.

1
 2
 3
4

*NAME OF SIGNER
 *By direction

1
2

Copy to:
 Short title of information addressee (see SNDL)
 Short title of second information addressee

ITALICS: OPTIONAL ITEMS
 ASTERISKS: ITEMS YOU MAY STAMP
 UNDERLINED NUMBERS: TYPEWRITER LINES

ISNP0011

Figure 3-9.—Format of unclassified naval letter (first page).

1
2
3
4
5
6
1
2

Subj: NORMAL WORD ORDER, ALL LETTERS CAPITALIZED

while this sample illustrates a file copy of a standard letter's signature page.

- a. If you use a copy-to block, type it on all copies.
 - b. If you use a blind-copy block, add it to internal copies only.
 - c. If you identify the writer and typist, do so on the file copy only.
4. A standard letter uses no complimentary close.

1
2
3
4

N. S. HALE
By direction

1
2

Copy to:
USS CLARK (FFG 11)
USS HALYBURTON (FFG 40)

1
2

Blind copy to:
387.2
967

Writer: E. Thomas, 385.6, X75366
Typist: R. Peeler, 15 Jul 95

ISNP0012

Figure 3-10.—Format of unclassified naval letter (second and succeeding pages).

BUSINESS LETTER

The business-form letter is used for corresponding with persons or agencies outside the Department of Defense who have not adopted or are not familiar with the naval form of correspondence.

Classification and Special Markings

The special requirements for a business letter that is classified or designated "For Official Use Only" are the same as prescribed for a naval letter. (Refer to the Correspondence Manual along with OPNAVINST 5510.1 (Security Manual) for guidance.)

MEMORANDUM

A memorandum provides an informal way to correspond within an activity or between several activities. Subordinates may use it to correspond directly with each other on routine business. However, it may not be used to issue directives.

There are four memoranda formats: *printed form*, *plain paper*, *letterhead*, and *memorandum for*. The choice is largely at the discretion of the originator and should be based on what suits the subject, occasion, and audience best. The first three formats are used for informal communications between subordinates, usually within the same activity. They may be directed to one or more addressees. The "memorandum for" is a more formal and often more official format used for communicating with high-level officials who themselves have adopted the format (such as the Secretary of Defense, the Secretary of the Navy, or one of their executive assistants).

POINT PAPER

A point paper is a brief summary of information and facts that provides the reader with a concise statement and presentation of points relating to its subject. Point papers are used to assist in developing or stating policy, in determining courses of action and resolving differences, and in preparing an individual for appearance before congressional committees and staffs, briefings, meetings, and conferences. The optimum point paper consists of one page upon which all key or significant information is displayed.

Types of Point Papers

There are two formats used in the preparation of point papers: the "hardware" and the "issue" or "topic"

point paper. A "hardware" point paper (see figure 3-11) could be used to provide a brief about aircraft, missiles, ships, weapons, and so forth. Figure 3-12 is the format used to brief an individual or group on a specific topic or issue.

General Form at Instructions

Although brevity is essential in point papers, it must not be achieved at the expense of clarity. Needless words and phrases should be eliminated. If necessary for brevity, phrases or clauses may be used in lieu of complete sentences, provided the thought to be conveyed is clear. Where necessary, detailed discussion, statistical tabulation, lengthy chronology, history or rationale, and so forth, should be appended as a tab.

Abbreviations and acronyms may be used freely, as long as they are either well known or introduced as follows:

- On initial use, the abbreviation or acronym is followed by the spelled-out word or phrase in parentheses. Thereafter, the abbreviation or acronym may be used.
- Unusual technical terms, phrases, code names, equipment identification, and so forth, must be clearly defined or explained, since the reader may not be as completely familiar with a subject as is the author.

Point papers should be classified according to content and marked for downgrading according to appropriate security instructions. Each title paragraph should be labeled as to its classification. Consistent with security and clarity, the title or subject of a point paper should be unclassified.

All tabs to a basic point paper should normally be listed alphabetically in the lower left-hand corner of the first page. If applicable, the codes of the offices with which coordination was actually accomplished, or which have cognizance of the subject matter of the point paper, should be listed as the last item.

MESSAGE

A message is a written thought or idea, expressed briefly and to the point, and prepared for transmission by the most suitable means of telecommunications.

(CLASSIFICATION)

Rank, name, service
Code, tel. number
Date of preparation

SUBJECT or TITLE (*)

CONCEPT/MISSION (*) - Brief, general statement. Avoid technicalities and do not include description.

DESCRIPTION/
CHARACTERISTICS - General description of major physical or performance characteristics. Identify major contractors. Tabular form preferred if appropriate. Put further details in a tab.

STATUS (*) - Summarize or outline. Where does the program stand now? List salient, factual items only. Be concise and put details in a tab.

PROBLEMS (*) - Specific, factual, concise outline of key problems or significant impact items only. List corresponding corrective actions contemplated or in progress. Compare Navy-OSD positions, if pertinent.

FORCE LEVELS (*) - Concise tabulation. Use most current data and identify source (FYDP, DPM, PCD, etc.) Show Navy-proposed vs. OSD-approved, if pertinent. Address current FY and up to six out-years.

FUNDING/
PROCUREMENT (*) - Funding data must be current, accurate, and displayed in a format which will enable the reader to clearly understand the information presented. If information is lengthy a tab may be used.

UNIT COST (*) - See explanation above.

COG/COORD - If applicable, the names of individuals or office codes with which coordination was actually accomplished, or which have cognizance of the subject matter of the point paper.

TAB A - Subject or title

TAB B - Subject or title

* Classification if point paper is NOT unclassified.

(CLASSIFICATION)

ISNP0013

Figure 3-11.—Hardware point paper format.

(CLASSIFICATION)

Rank, name, service
Code, tel. extension
Date of preparation

TITLE or SUBJECT (*)

- CONCEPT/MISSION (*) - A brief, (one or two sentences) statement of the concept, idea, or purpose of the paper.
- BACKGROUND (*) - Brief description of issue, topic, or program and generating factors. Salient, factual information. Ensure clear understanding. Avoid lengthy discussion.
- STATUS DISCUSSION (*) - Concise, factual statement of current status. Relation to established guidelines, goals, steps, predictions; recent or proposed developments, trends, progress, changes, plans, forecasts.
- PROBLEMS (*) - Specific, concise. Impact of unresolved problems, critical decision dates, contingent requirements, etc. State specific corrective actions in progress or contemplated. Avoid broad, general, nonspecific recommendations or requests for action.
- Other paragraphs, titled as required (*) - To avoid "clutter" use minimum additional paragraph headings necessary for clarity. Every attempt should be made to include all pertinent information within standard paragraphs, above. Basic paper should be one page. Put detailed discussion, rationale, etc., in tabs, not in basic paper.
- FUNDING (*) - See figure x-xx
- COG/COORD - See figure x-yy

TAB A - Subject or title.
TAB B - Subject or title.

* Classification if point paper is NOT unclassified.

(CLASSIFICATION)

ISNP0014

Figure 3-12.—Issue or topic point paper format

Message Content and Format

A variety of message formats are used in telecommunications. The format used depends upon the method and mode of operation. For example, Automatic Digital Network (AUTODIN) message procedures and formats differ from those used in radiotelephone (R/T) and manual teleprinter communications. Although there are many types and modes of communications, the basic naval message must conform to a standard format.

Common Message Elements

Before covering the basic format of military messages, we will first discuss the time system, precedence categories, and speed-of-service objectives used in naval communications.

DATE-TIME GROUP.— The date-time group (DTG) is assigned for identification and file purposes only. The DTG consists of six digits, a time zone designator, and the month and year abbreviations; for example, 221327Z AUG 94. The first two digits represent the date, the second two digits represent the hour, and the third two digits represent the minutes. The month is expressed by its first three letters and the year of origin, by its last two digits. Our example above, 221327Z AUG 94, represents the 22nd day of August, 1994, at 1327 Greenwich mean time (GMT). Dates from the first to the ninth of the month are preceded by a zero. We will talk more about the GMT system shortly.

The zone suffix ZULU (Z), for Greenwich mean time, is used as the universal time for all messages. The exception is where theater or area commanders prescribe the use of local time for local tactical situations. To avoid confusion at midnight, never use 2400Z or 0000Z as the time of a message. Use either 2359Z or 0001Z, as appropriate.

Greenwich Mean Time.— In naval communications, the date-time group is based on a common worldwide standard. To meet the need for worldwide time standardization, the international Greenwich mean time (GMT) system was developed. The GMT system uses a 24-hour cycle instead of the two 12-hour cycles used in the normal civilian world.

Precedence

The message drafter indicates the desired writer-to-reader delivery time through the assignment

of a message precedence. Although the drafter determines the precedence, the releaser should either confirm or change it. (We will talk more about the responsibilities of the drafter, originator, and releaser later in this chapter.)

Precedence is assigned according to urgency, based solely on writer-to-reader time, not according to the importance of the subject matter or the text. For example, an unclassified message may be assigned an IMMEDIATE precedence, whereas a Secret message may be assigned a ROUTINE precedence. In this situation, the unclassified message requires fast action or response, whereas the Secret message may not require any action at all.

The following paragraphs list the various precedence categories, their indicators, and basic definitions:

ROUTINE (R)— This category is assigned to all types of traffic that justifies electrical transmission but is not of sufficient urgency to require a higher precedence.

PRIORITY (P)— This category is reserved for messages that furnish essential information for the conduct of operations in progress. This is the highest precedence normally authorized for administrative messages.

IMMEDIATE (O)— This category is reserved for messages relating to situations that gravely affect the national forces or populace and which require immediate delivery to addressees.

FLASH (Z)— This category is reserved for initial enemy contact reports or operational combat messages of extreme urgency; message brevity is mandatory.

YANKEE (Y)— In addition to the four major precedence categories, an EMERGENCY COMMAND PRECEDENCE (ECP) is used within the AUTODIN system. This ECP is identified by the precedence prosign Y and is limited to designated emergency action command and control messages.

Speed-of-Service Objectives

Many factors affect writer-to-reader delivery time. These factors include the types of facilities and systems used, traffic volume, relay requirements, message length, the number of addressees, and circuit conditions. The speed-of-service objectives in

table 3-1 provide general guidance. However, message traffic must be handled as rapidly as possible, consistent with reliability and security.

Basic Format of Military Messages

The message format is divided into three distinct parts: (1) heading, (2) text, and (3) ending. There are 16 format lines that make up these three parts. Each format line corresponds to a particular type of information and places the contents of a message in standard Sequential order.

Referring to table 3-2, you can see which format lines make up the three major parts of a message. They bear no relationship to the number of typed lines contained in each format line. For example, format line 4 is used for relaying instructions. These instructions may total several lines on a typewritten message. Format lines play a crucial role in the accountability, identification, and processing of a message.

Special-handling Markings

Certain types of messages require special handling in addition to that provided by the security classification. Markings for this special handling are placed in the classification line immediately following the classification. Some of the more common special-handling markings that you will see are:

- Ž SPECAT (Special Category);
- Ž LIMDIS (Limited Distribution); and
- Ž PERSONAL FOR.

SPECAT messages come in two variations. One type includes both the general SPECAT and the SPECAT Single Integrated Operational Plan—Extremely Sensitive Information (SPECAT SIOP-ESI).

Table 3-1.—Speed-of-Service Objectives

PRECEDENCE	PROSIGN	SPEED-OF-SERVICE OBJECTIVES
FLASH	Z	As fast as possible with an objective of less than 10 minutes
IMMEDIATE	O	30 minutes
PRIORITY	P	3 hours
ROUTINE	R	6 hours

This type of SPECAT message is associated with code words or projects. For example, a Secret message whose subject matter deals with a special project entitled "TACAMO" would have a classification line reading SECRET SPECAT TACAMO. SPECAT SIOP-ESI messages are always classified Top Secret. SPECAT (less SIOP-ESI) messages must be classified at least Confidential

SPECAT messages are handled only by personnel who are authorized to view them by written approval of the commanding officer.

LIMDIS messages are associated with special projects, cover names, or specific subjects. These messages require limited distribution within the addressed activity to personnel with a need to know and who are specifically authorized by the command to have access to the information. Only classified messages qualify for the special-handling marking LIMDIS. However, the classification is still assigned according to the subject matter. The classification line of a Secret LIMDIS message would read SECRET LIMDIS.

PERSONAL FOR messages may be unclassified or classified and are reserved for flag rank and command status officers. Distribution of these messages is limited to the named recipient (who may direct further distribution). In PERSONAL FOR messages, the classification line always shows the name or title of the intended recipient and may show the name or title of the originator. For example:

C O N F I D E N T I A L PERSONAL FOR ADM W. T. DOOR
//N00000//

(CONFIDENTIAL FOR TRAINING, OTHERWISE UNCLASSIFIED)

or

UNCLAS PERSONAL FOR ADM W. T. DOOR FROM ADM J. R. FROST
//N00000//

PERSONAL FOR messages are used only by and addressed only to Navy commands.

Restricted Data and Formerly Restricted Data Markings

Some types of information are defined as Restricted Data or Formerly Restricted Data. This means that the information falls into one of the Several categories of nuclear-oriented subject matter under the Atomic Energy Act of 1954.

Table 3-2.—Basic Message Format

BASIC MESSAGE PART	FORMAT LINES CONTAINED	GENERAL FORMAT-LINE CONTENT
HEADING	1	Used in automated systems and TTY relay
	2	Station(s) called and exempted station(s)
	3	Prosign DE (or from) and calling station
	4	Instructions; for example, T (relay)
	5	Precedence and DTG
	6	Prosign FM (the originator of this message is) and originator
	7	Prosign TO and action addressees
	8	Prosign INFO and the information addressees
	9	Prosign XMT and the exempted addressees
	10	Accounting symbol, group count, SVC (service), and PDC
Separation	11	Prosign BT (Break)
TEXT	12	Basic idea of originator
Separation	13	Prosign BT (Break)
ENDING	14	Time group (where appropriate)
	15	Final instructions (where appropriate); for example, Prosign B more to follow
	16	Ending sign; for example, K or AR

When such information appears in the text of a message, the symbols RD or FRD are added to the classification markings. For example, if a paragraph of a message is classified Secret and is also Restricted Data, the paragraph must be marked S-RD. If the paragraph is classified Confidential and is also Formerly Restricted Data, it would be marked C-FRD. These markings are spelled out after the security classification in the subject line.

CLASSES AND TYPES OF NAVAL MESSAGES

As an Intelligence Specialist, you will handle and process various classes and types of naval messages. Therefore, you *must* know the various categories of messages. How you handle and process a message depends upon its type and classification. For example, messages designated as SPECAT require that only personnel designated by the commanding officer be allowed to process them.

CLASSES OF NAVAL MESSAGES

Messages are placed in different classes to aid in administration and accounting, especially where tolls and charges are involved. In general, there are five classes of message: A, B, C, D, and E. Of the five classes, A, B, and C are U.S. Government messages. Classes D and E are non-U.S. Government (private) messages.

Class A messages makeup the largest volume of message traffic handled by the Navy. Messages of this class are originated by Department of Defense (DOD) activities and sent to DOD activities. This includes the Coast Guard when it is operating as a part of the Navy.

Class B traffic includes official messages originated by and destined for U.S. Government agencies other than the DOD. When the Coast Guard is not operating as a part of the Navy, Coast Guard traffic falls into the class B category.

Class C messages consist of broadcast traffic in special forms and available to ships of all nationalities; for example, hydrographic data, weather, time signals, and so forth.

Class D messages are private messages for which the Navy collects tolls. This group includes radiotelegrams and press messages sent by correspondents aboard ship.

Class E messages are personal messages sent to and from naval personnel, handled free of charge over naval circuits. Charges are collected from the sender only when a commercial communications company, such as Western Union, handles the message over part of its route. The class E message privilege is used mainly to enhance morale. It provides a means of communicating urgent personal matters for personnel at sea. This privilege is not available between points on shore within the United States.

TYPES OF MESSAGES

Naval communications enable naval commanders to make their will known and, as such, are the voice of command. Naval messages speak for and with the authority of the commanders who originate them.

All official messages, whether classified or not, contain privileged information. No person is entitled to knowledge or possession of either classified or unclassified communications solely by virtue of grade,

position, office, or clearance. There must be a need to know before a person can have knowledge of the contents or possession of a message. The contents of all personal and commercial messages handled by naval communications are revealed only to the person(s) to whom they are addressed and to the communications personnel who must handle them.

Commercial messages concerning emergencies, such as death, serious illness, and injury, must be processed with adequate precautions to prevent their contents from being disclosed to the addressee in a rash manner. Normally, local instructions clarify these particular methods.

You must remember that there are many types or categories of naval message. Each type or category receives different treatment with reference to internal routing and distribution. However, there are certain categories of message traffic that are common in communications. These message categories are usually similar in format and are easily recognizable. When not similar in format, they are usually recognizable by content. Although space precludes a total discussion of all the various message categories, the following is a discussion of the most common.

General Messages

General messages provide a standard distribution to a large group of addressees and are identified by a repetitive short title (for example, ALNAV, NAVOP, JAFPUB).

All commands to whom general messages are distributed are action addressees. However, each command receiving a general message is responsible for determining what action, if any, it needs to take on the message.

Although general messages have a wide, standardized distribution, all addressees may not need to take action. However, commands are required to keep a continuous numerical file of all general messages for which they are on the distribution list and receive. Consequently, the general message files should contain every general message received during the calendar year, in numerical order. The general message files are separate from all other files and are subdivided according to identifying title or type. Figure 3-13 shows a typical heading of a general message.

```

P 171731Z MAY 94
FM CNO WASHINGTON DC//094//
TO ALCOM
BT
UNCLAS //NO2300//
ALCOM 026/94
SUBJ: GENERAL ADMINISTRATIVE (GENADMIN) MESSAGE TEXT FORMAT (MTF)

```

Figure 3-13.—Typical heading of a general message.

In this example, the line immediately before the subject line is used to inform the reader that this is the 26th ALCOM message of 1994. The designation ALCOM indicates the message is intended for wide distribution throughout the Navy.

General messages are canceled in the following ways:

- The first general message of a calendar year lists those messages of the previous year(s) (by number) that remain in effect. Messages not listed are automatically canceled. If necessary, interim cancellation messages may be sent at other times during the year.
- An individual general message may include its own cancellation date within the text. Additionally, a subsequent message of the same general message series may cancel a message.
- General messages that do not have a yearly cancellation message and are not assigned particular cancellation dates are automatically canceled 90 days from the DTG.

American Red Cross Messages

The American Red Cross (AMCROSS) may use the facilities of naval communications, free of charge, for sending and receiving emergency and administrative traffic as prescribed in *U.S. Navy Regulations, 1990*. However, in each case, this privilege is subject to the approval of the commanding officer, who may refuse to extend this service if it would interfere with naval administration or operations.

Red Cross messages are handled as class B traffic and are normally in plain text. Most Red Cross

messages are assigned a precedence of ROUTINE; however, critically important ones may be assigned up to IMMEDIATE precedence over naval circuits. When the Red Cross is assisting during a civilian disaster, message traffic may be given equal precedence with military traffic (over naval circuits) at the discretion of the senior officer present at the scene of the disaster.

As a rule, Red Cross traffic is not accepted if it cannot be handled entirely over naval or Defense Communications System (DCS) circuits. The exception to this rule is traffic that is related to emergencies or disasters involving relief.

Since AMCROSS messages contain information that is very personal to the recipient, communications personnel are not to discuss the contents of the message with anyone. Distribution of AMCROSS messages is limited to the executive officer or appointed alternate only. Local command policy dictates filing and handling procedures for AMCROSS messages.

Commercial Messages

Sometimes a class A or B message must be sent over commercial communications circuits. When a commercial communications company is involved in a portion of the handling or in the final delivery of a class A or B message, the company is paid for the charges incurred out of government funds. For detailed information on handling commercial messages, refer to *Commercial Communications Instructions, NTP 9*.

Pro Forma Messages

Pro forma messages are messages whose subject matter and sequence of textual content are preset and

cannot be changed by the originator. Figure 3-14 is an example of a pro forma message used to update a previously reported electronics casualty report (CASREP). Notice that the textual sequence of information follows a preset format and that it does not have a subject line. Also notice that classification markings are not applied to paragraphs or subparagraphs. The message assumes the overall classification given in the classification line.

Pro forma messages enhance the standardization of repetitive message subject matter and ensure less ambiguity in these areas. They encompass a large variety of messages, such as publication change recommendations, hydrographic information, and movement reports. Pro forma messages reduce the chance of error through interpretation. This is important, especially in movement reporting where misinterpreted information could mean an at-sea collision or result in communications personnel copying the wrong broadcast, thereby missing their traffic.

Many pro forma messages are computer-generated and computer-processed. A number of automated systems, such as the Worldwide Military Command and Control System (WWMCCS) and those used in Tactical Support Centers (TSCs), are capable of automatically generating messages with varying degrees of required message formats. These types of messages are normally destined for a communications central processor designed to accommodate and route such traffic. They may also simply be processed directly into normal communications channels.

Minimize Messages

Military telecommunications systems tend to become overloaded during an emergency. Naturally, it becomes necessary to reduce unnecessary traffic volume to clear user circuits for essential traffic. This reduction in traffic is accomplished by use (usually by message) of the word "MINIMIZE." Minimize means **"It is now mandatory that normal message and telephone traffic be reduced drastically so that vital messages connected with the situation indicated will not be delayed."**

A message ordering minimize consists of the word "MINIMIZE," followed by the area affected (scope), reason, and duration of the minimize condition (when known).

The Chief of Naval Operations (CNO), fleet commanders-in-chief, and area coordinators are

authorized to impose minimize conditions on users of naval communications systems. Subordinate commanders may impose minimize over elements of their commands only with prior permission from one of the three authorities just mentioned.

During minimize conditions, FLASH and IMMEDIATE traffic should be restricted to a maximum of 100 and 200 words, respectively. Message releasers are also kept to a minimum and must be specifically designated in writing. *Basic Operational Communications Doctrine (U)*, NWP 6-01, contains information pertaining to the types of normal, environmental, and supply traffic that may be sent over normal channels and circuits during minimize.

Service Messages

Service messages are short, concise messages between communications personnel. These messages have the authority of an official communication and must receive prompt attention. If the action requested in a service message cannot be accomplished within a reasonable time, the station originating the service message should be notified. Service messages are normally assigned a precedence equal to the message being serviced.

Service messages deal with many topics. You will find that most deal with corrections, repetitions, broadcast reruns, and misrouted or missent messages. You must remember that a service message should be dealt with promptly and retained until all actions concerning it have been completed. Once action is complete, it is good practice to attach a copy of the service message to the serviced message when it is filed, or mark it with the DTG of the service(s).

Requests for information through service messages should be as brief, concise, and accurate as possible. Careful attention to detail and the use of proper operating techniques by communications and crypto personnel will reduce the number of service messages required.

Service messages are normally prepared in abbreviated plaindress format and may be assigned sequential reference numbers. (We discuss plaindress messages later in this chapter.) The service message number immediately follows the abbreviation "SVC" in the message text. If used, sequential service reference numbers may continue throughout the calendar year. When you reply to a service message received with a reference number, refer to the reference number in the text of the reply. For example:

P 010914Z JUN 94

FM USS KITTY HAWK

(1) TO COMSECONDFLT

CTG TWO ZERO PT TWO

COMNAVAIRLANT NORFOLK VA//00//01//31//

NAVSSSES PHILADELPHIA PA//46//48//03P//

INFO AIG SIX EIGHT FOUR THREE

NUSC NEWPORT RI//JJJ//

COMSPAWARSYSCOM WASHINGTON

DC//02//31//32//34//38//

NAVSHIPWPNSYSENGSTA PORT HUENEME CA//JJJ//

NAVSHIPWPNSYSENGSTA NORFOLK

VA//00//01//02//63//67//

BT

C O N F I D E N T I A L

(2) MSGID/CASREP/CV 63 KITTY HAWK/29//

(3) POSIT/PHILADELPHIA/010800ZJUN94//

(4) REF/CASUALTY/SARATOGA/131744ZMAY94//

(5) CASUALTY/CORRECT-86012/NO. 1 OXYGEN ANAL/EIC:F300/CAT:2//

(6) AMPN/TEN HOUR DELAY IN RECEIPT OF PARTS. 138 MANHOURS
EXPENDED TO CORRECT. 2100 HOURS SINCE LAST FAILURE-
CONTINUOUS USE. PARTS RECEIVED LIST: DLO1 132044ZMAY94
DL02 132044ZMAY94 DL03 142230ZMAY94 DL04 142230ZMAY94

(7) DWNGRADE/DECL 01DEC94//

BT

(CONFIDENTIAL FOR TRAINING, OTHERWISE UNCLASSIFIED)

Figure 3-14.—Example of a pro forma message.

UNCLAS SVC //N00000// ZUI SVC
0245 RUEDCSA1234 1921600

This example is a service message inviting attention (ZUI) to a previous service message with a reference number of 0245. Occasionally, you will see the acronym COSIR in a service message text, which means "Cite Our Service in Reply." Authorized operating signals are used to the greatest extent possible in service messages, but clarity must not be sacrificed for brevity.

The security classification is the first word of all service message text. This is followed by the abbreviation "SVC." If the service message requires special handling, the special-handling designator follows the security classification. For example:

UNCLAS SVC or SECRET SPECAT SIOP
ESI SVC

A service message may quote the textual content of a classified message or refer to the classified message in a manner that reveals textual content. In this case, the service message must be assigned the same classification as the classified message being serviced.

Tracer Message

Tracer messages are special types of service message. Tracers are sent to determine the reason for excessive delay or nondelivery of a message previously sent. Normally, tracer requests are initiated by a message originator or addressee. However, a situation may dictate that tracer action be initiated by the originating communications station, the relay station, or the communications station of the addressee.

Tracer action continues on a station-to-station basis until the cause of delay has been determined. Upon receipt of a tracer, a station examines its records for the time of receipt and transmission of the message being traced. It compiles this information and transmits it with the tracer action to the preceding station(s) and to the station that originated the tracer. The station that caused the delay or nondelivery must cite the reason and provide a summary of corrective action in the report.

Tracer action requests must be initiated as soon as the discrepancy is discovered. Action must be initiated no later than 4 days after the original time of transmission for a tactical addressee. For nontactical addressees, action must be initiated no later than 30 days

from the original time of transmission. In-station records, files, logs, and tapes must be retained beyond the required retention limit if tracer action is in progress prior to the expiration date. You can find detailed information concerning tracer action in *Automated Digital Network (AUTODIN) Operating Procedures*, JANAP 128.

Communications Guard Shift Messages

Communications guard shift (COMMSHIFT) messages are required when a command shifts its guard (monitoring) from one broadcast or servicing communications center to another. When possible, the shift takes effect at 0001Z of the new radio day. When broadcasts are shifted, an overlap period before and after the effective time is observed to ensure continuity of traffic. The command guards both broadcasts during the overlap period.

COMMSHIFT messages are sent to the NCTAMS of the communication areas from which the old and the new broadcasts originate. COMMSHIFT messages are necessary because of operational considerations or changes in the deployment schedule of a ship. These messages are necessary when a command needs to make a shift at a time other than that indicated by its movement report. Detailed information concerning communications guard shift messages and formats is contained in *Fleet Communications (U)*, NTP 4 (NOTAL).

Broadcast Screen Requests

Broadcast screen requests (BSRs) are service messages to request the rerun (ZDK) of missed or garbled messages. BSRs are sent to the Broadcast Keying Station (BKS) or to the designated broadcast screen ship that is responsible for the broadcast channel. NTP 4 provides detailed information and prescribes the proper format for drafting a BSR.

COMMSPOT Reports

COMMSPOT reports are used to advise of any situation that might cause significant disruption of tactical communications. All ships submit these reports when they encounter unusual communications difficulties. Any ship experiencing unusual communications difficulties must send a COMMSPOT report as soon as possible to minimize further deterioration of the communications situation.

JCS Emergency Action Messages

Joint Chiefs of Staff (JCS) Emergency Action Messages (EAMs) contain key instructions or information from high-level authority and have predetermined formats (pro forma). Such messages are transmitted by various communications systems and normally carry FLASH (Z) precedence. They are vital messages of an extremely time-sensitive nature, and rapid processing is mandatory to achieve the fast reaction required by their content. Usage and handling procedures are issued by the JCS to those who have a need to know.

Movement Reports

Many naval ships are deployed at any given time. For command and administrative purposes, it is necessary to have up-to-the-hour information on unit locations. The dissemination of movement report information is the function of the Movement Report (MOVREP) system. The MOVREP system provides the Worldwide Military Command and Control System (WWMCCS) with ship location information.

The controlling agency of the MOVREP system is the Navy WWMCCS Data Control Center located in Washington, D.C. The agency is designated NWDC WASHINGTON DC. There are two movement reporting centers (MRCs): CINCLANTFLT Headquarters (MRC NORFOLK VA) and CINCPACFLT Headquarters (MRC PEARL HARBOR HI).

MRCs coordinate the MOVREP system within their assigned geographic areas, monitor reports submitted for timeliness and accuracy, and issue corrective messages as necessary. They also act as contact point for all matters concerning the reporting of the location of U.S. Navy forces.

A U.S. Navy vessel sends a MOVREP message 24 to 48 hours before getting under way. This message states the time of departure, destination, route, speed of advance and any other significant information.

The message enters the system through the MRC controlling the area in which the ship is located. The MRC then disseminates the ship's movement information to commands that have a need to know. Such activities include other MRCs that a ship will pass en route, supply centers, fleet post offices, NCTAMS, and fleet weather facilities. Movement reports are prepared according to *Operational Reports*, NWP 1-03.1.

Q Messages

Allied nations have navigational warning systems that are used primarily during wartime. Certain portions of these systems are used to distribute classified information of a sensitive nature. An example would be information concerning minefield and open channels. Classified portions of allied navigational warning messages are identified as "Q" messages. Occasionally, the Q system is used in peacetime fleet exercises at the discretion of the officer conducting the exercise (OCE).

Submarine Check Reports

Submarine check reports (figure 3-15) are used to ensure the safety and accountability of submarines. Check reports are unclassified and are assigned an IMMEDIATE precedence. These reports can be identified by the word "CHECK" as the first word of the text. When check reports are received, they are given proper and expedient handling. Delays and nondelivery of these reports can result in the initiation of SUBMISS/SUBSUNK procedures. The words "TWO FOUR" contained in the text of the message in figure 3-15 indicate that the submarine is on a 24-hour check schedule.

```
0 190810Z DEC 94

FM      USS FRANCIS SCOTT KEY

TO      COMSUBRON EIGHTEEN

INFO    COMSUBGRU SIX
        COMSUBLANT NORFOLK VA

BT

UNCLAS

CHECK TWO FOUR SUBMARINE
FRANCIS SCOTT KEY.

BT
```

Figure 3-15.—Example of a submarine check report

Notices to Airmen

Notice to Airmen (NOTAM) messages are originated by military activities and civil agencies concerned with the safety of aircraft. The NOTAMs concern aerological facilities, services, and hazards to aircraft.

Hydrographic Messages

Hydrographic messages provide navigational warnings to ships. These message reports may include such information as casualties to various types of navigational aids; marine, air, or submarine disasters; and searches for survivors. They may also include selected exercises and hazardous operations conducted by units of the Armed Forces. Hydrographic messages are identified as "HYDROLANT" or "HYDROPAC," followed by a serial number.

Message Cancellations

In naval communications, many types of messages have self-contained cancellation dates. Others, such as those in the Navy directives system, are automatically canceled after 30 days except when:

- Ž The text provides for an earlier cancellation;
- Ž A subsequent message extends the cancellation date; or
- Ž The directive is reissued by the originator in standard format within 30 days of the original release date.

In all cases, you should remember that only the originator has the authority to cancel a message. To do this, the originator drafts and releases an entirely separate message that refers to the message to be canceled. Messages can NOT be canceled by service messages.

When a message contains information that becomes obsolete by a certain time, it is indicated by the statement THIS MESSAGE IS CANCELED AT (TIME/DATE).

MESSAGE AND ROUTING ADDRESSEES

Most messages have at least one addressee responsible for taking action on their contents and for originating any necessary reply. Addressees who have an official concern in the subject of the message, but

who do not have primary responsibility for acting on it, receive the message for information. Although information addressees are usually concerned only indirectly with a message, they occasionally must take action of some kind within their own commands. Some messages contain only information addressees.

Messages may be divided into types, according to the way they are addressed, as follows:

Single-Address— A message that has only one addressee, which may be either for action or information.

Multiple-Address— A message that has two or more addressees, which may be either action or information, and where each addressee is informed of all other recipients.

Book— A message destined for two or more addressees but where the drafter considers it unnecessary that each addressee be informed of other addressee(s). Book messages are routed according to each addressee's relay station. All unnecessary addressees are deleted from the face of the message before the message is sent to the addressee(s) served by that particular relay station.

General Message— A message that has a wide, predetermined, standard distribution. General messages are normally titled with a sequential number for the current year; for example, ALCOM 28/94, NAVOP 30/94. The title indicates distribution and serves as the address designator.

ADDRESS GROUPS

Address groups are four-letter groups assigned to represent a command, activity, or unit. In military communications, address groups can be used in the same manner as call signs to establish and maintain communications. Generally speaking, the Navy uses address groups in the same way as call signs. Address groups never start with the letter N, hence, they are easily distinguishable from naval radio call signs. Address groups, however, follow no distinctive pattern, and the arrangement of the four letters that constitute them conveys no significance whatsoever.

Afloat commands (except individual ships) and shore-based commands or activities not served by their own communications facilities are assigned address groups. For example:

- Senior commands and commanders ashore, such as the Secretary of Defense and the Secretary of the Navy;
- Navy bureaus, systems commands, and district commandants; and
- Elements of the Shore Establishment having a need for direct addressing and receipt of message traffic (such as weather centrals).

Among other uses, address groups make delivery of message traffic easier when a communications center serves so many activities that its own call sign is insufficient to identify the addressee. Like call signs, address groups are divided into the following types:

- Individual activity;
- Collective;
- Conjunctive;
- Geographic;
- Address indicating; and
- Special operating.

Individual Activity Address Groups

Individual activity address groups represent a single command or unit, either afloat or ashore. For example:

DTCI—COMNAVSURFLANT, and
SSMA—CHIEF OF NAVAL OPERATIONS (CNO).

Collective Address Groups

Collective address groups represent two or more commands or activities. Included in this group are commanders and their subordinate commanders. For example:

JTBC—DESRON 6; and
YQHV—SUBRON 16.

Conjunctive and Geographic Address Groups

Conjunctive and geographic address groups are discussed together because they are interrelated in their usage.

Conjunctive address groups have incomplete meanings and must have geographic address groups added to them to denote a specific command or location. For this reason, conjunctive address groups are used

only with one or more geographic address groups. For example, the conjunctive address group XZKW means “All ships present at _____.” To complete the meaning, it must be followed by a geographic address group.

Geographic address groups are the equivalent of geographical locations or areas. They are always preceded by conjunctive address groups. For example, the address group DEXL could represent Newport, R.I. Therefore, all ships present at Newport would be addressed XZKW DEXL.

Address Indicating Groups

Address indicating groups (AIGs) represent 16 or more specific and frequently recurring combinations of action or information addressees. The purpose of AIGs is to increase the speed-of-traffic handling. They shorten the message address by providing a single address group to represent a large number of addressees. This eliminates individual designators for each address used in the heading.

Messages that are repetitively addressed to a constant group of 16 or more addressees can effectively be processed by an AIG address designator. For example, let’s assume that a hypothetical AIG (AIG 31) is used to address SUBMISS/SUBSUNK message traffic by COMSUBLANT to 30 action addressees and 35 information addressees. Since a single AIG (AIG 31) is used, 65 call signs and address groups are eliminated from the heading of the message.

AIGs are normally created when particular types of message traffic become repetitive enough (at least 12 times a year) and are addressed to enough of the same addressees to warrant it. Among such message traffic are:

- Alerts, air defense warnings, operational or emergency actions, and so forth;
- Destructive weather warnings, such as hurricanes and typhoons;
- Logistical transactions and reports;
- Intelligence summaries;
- Movement reports, such as aircraft, ships, and personnel; and
- Notices to airmen (NOTAMs).

A point for you to remember is that an AIG will not be established for groups of addressees numbering less than 16. A complete listing of AIGs by number,

cognizant authority, and purpose are contained in *U.S. Navy Address Indicating Group (AIG) and Collective Address Designator (CAD) Handbook, NTP 3 SUPP-1*. A partial listing of AIGs, along with specific action and information addressees, can be found in *U.S. Call Sign and Address Group System—Instructions and Assignments (U.S. Supplement No. 1)*, ACP 100 U.S. SUPP 1.

In a multiple-address message, sometimes not all addressees are required to have all the references listed in the message. References that may not be held by all addressees are indicated by the acronyms NOTAL (not to or needed by all) and PASEP (passed separately). These acronyms, when used, are added after the reference. They may also be used together for the same reference.

Special Operating Groups

Special operating groups (SOGs) are four-letter groups that are identical in appearance to address groups. SOGs are provided for use in the headings of messages to give special instructions. However, SOGs are not used unless specifically authorized by CNO. They must always be encrypted. SOGs may be used singly or with encrypted or unencrypted call signs or address groups.

COLLECTIVE ADDRESS DESIGNATOR

The collective address designator (CAD) is a single-address group that represents a set of four or more activities, including the cognizant authority, linked by an operational or administrative chain of command. Examples of CADs, their cognizant authorities, and purposes are shown in table 3-3.

Table 3-3.—Collective Address Designators

CAD	AUTHORITY	PURPOSE
ALL SSBNS PAC	COMSUBPAC, PEARL HARBOR HI	Promulgate information of an operational/gen- eral nature to all SSBNs PAC
ALL AFLOAT UNITS ATLANTIC COMMAREA	NCTAMS LANT, NORFOLK	Promulgate communications matters to afloat units

CALL SIGNS

Call signs are made up of letters, letter-number combinations, or one or more pronounceable words. Call signs are used to identify communications activities and to establish and maintain communications. They are used in both military and civil communications and are divided into several categories, with some call signs belonging to more than one category.

International Call Signs

International call signs are assigned to radio stations of all countries, both civilian and military, afloat and ashore. These call signs are assigned according to international agreement. The United States is assigned the first half the A block (A through ALZ) and all the K, W, and N blocks. The call signs are assigned as follows:

A block	Army and Air Force;
K and W blocks . . .	Commercial and private stations, merchant ships;
N block	Navy, Marine Corps, Coast Guard.

Naval shore communication stations have three-letter N calls. For example, NAM is the call sign for NCTAMS LANT Norfolk. The exception to the three-letter N calls for naval shore communication stations is NAVCOMTELSTA Spain (AOK).

Call signs for fixed and land radio stations are listed in *Allied Call Sign and Address Group System—Instructions and Assignments*, ACP 100, and in its U.S. Supplement 1. International call signs assigned to U.S. Navy ships are four-letter N calls and are used for all nonmilitary international communications. For example, NJFK is the call sign for the USS *John F. Kennedy (CV-67)*.

International call signs for USN, USMC, and USCG aircraft are composed of N, NM, and NC, respectively. These letters are followed by the last four digits of the serial or systems command number of the aircraft.

Military Call Signs

Most ships of allied nations are assigned military call signs in addition to their international call signs.

When used to address messages, military call signs are always encrypted. Both international and military call signs are listed in *Call Sign Book for Ships*, ACP 113.

Collective Call Signs

Collective call signs pertain to two or more facilities, commands, or units. For example, NIMK . . . “All U.S. submarines copying this broadcast.” Collective calls are listed in ACP 113 and in the ACP 100 series.

ROUTING INDICATORS

Routing indicators identify stations in a communications relay network and are composed of from four to seven letters. It is easy to distinguish routing indicators from call signs and address groups. Routing indicators always begin with the letter *R*.

MESSAGE ADDRESSES

Absolute consistency in the format and spelling of each plain language address (PLA) was not critical before the implementation of automated message-processing systems. Because communications personnel processed all messages, deviations in address spelling were tolerated. This is no longer true. Message drafters must now verify the PLA for each addressee in the *Message Address Directory* (MAD) and not rely on memory or copy PLAs from incoming messages.

Message Address Directory (MAD)

The MAD contains authorized message addresses and is divided into five sections. The Navy section, “U.S. Navy Plain Language Address Directory (USN PLAD 1),” includes message addresses for Marine Corps and Coast Guard activities. MAD UPDATES are published four times a year to ensure that all addresses are current.

Plain Language Addresses

The plain language addresses (PLAs) listed in USN PLAD 1 are the only designators authorized for use in message addressing to Navy, Marine Corps, and Coast Guard activities. Deviation from USN PLAD 1 in spelling, spacing, or formatting cannot be tolerated because automated message-processing systems are keyed to USN PLAD 1 entries. These systems will reject (for operator intervention) any message that

contains an address designation in format lines 7 and 8 not constructed according to USN PLAD 1.

Plain Language Address Spelling

The MAD lists the authorized command short titles and geographical locations in message addressing. NTP 3 and the MAD contain the basic rules for proper spelling of numbers and geographical locations in message addresses. Some of the basic rules are:

- The use of any punctuation or other extraneous characters is prohibited.
- The numbers 10 through 19 are written as one word; for example, COMSUBRON SIXTEEN. Numbers 20 and above are spelled out digit for digit; for example, AIG SIX FOUR.
- The names of cities and towns are not abbreviated. States and country abbreviations are contained in the MAD.
- When the words “SAINT,” “MOUNT,” “POINT,” or “FORT” are used as a part of a geographic location, they are abbreviated as ST, MT, PT, and FT, respectively. When these same four words are used as a part of an activity short title they are not abbreviated; for example, USS MOUNT HOOD. The word “POINT,” when used as part of a task organization’s PLA, will be abbreviated; for example, CTG SEVEN ONEPT ONE.

Use of an ADMIN PLA

The word “ADMIN” is normally used in message traffic between flag rank commanders who are temporarily detached from their headquarters location and their staff. For example, when the flag rank commander is temporarily detached from the headquarters location, the FROM line of a message addressed to the staff would show the commander’s complete plain language address (PLA). The TO line would show the word “ADMIN” followed by the commander’s complete PLA, as in the following example:

FM COMSUBLANT NORFOLK VA TO ADMIN COMSUBLANT NORFOLK VA
--

When the commander is absent, the commander’s staff may use the proword ADMIN in the FROM line

of messages originated by the staff and destined to the activity maintaining the commander's communications guard with appropriate special delivery instructions. The following example illustrates the use of ADMIN:

FM ADMIN COMSUBLANT NORFOLK VA
 TO CNO WASHINGTON DC
 UNCLAS //N02310//CNO NOT AN ADDEE,
 PASS TO ADM BOAT FOR ACTION

USN PLAD 1 provides procedures for establishing an ADMIN PLA.

Office Codes

Office codes are required for all Navy shore activity PLAs. Office codes follow the PLA and are enclosed in double slants; for example, CNO WASHINGTON DC//094//. There is no limit on the number of office codes that can be used with a PLA. When multiple office codes are used with a PLA, the first code is the action code. A single slant separates multiple codes; for example, CNO WASHINGTON DC//094/611//. If an office code is not known, the code //JJJ// is used after the PLA. Office codes are not used with AIGs, CADS, or PLAs in pro forma messages. NTP 3 has further information concerning office codes used with PLAs.

PROSIGNS

Procedural signs, or prosigns, are letters or combinations of letters that convey frequently sent orders or instructions in a simple, standard format. Although some prosigns may seem to be abbreviations of their assigned meanings, prosigns are never referred to as abbreviations. Since you will be using prosigns, it is helpful to have a command of them. A recommended method of learning them is to prepare cards with a prosign on the front and its meaning on the back, and use them for self-drill. The following is a complete list of authorized prosigns:

- Precedence Prosigns:
 - Z FLASH
 - O IMMEDIATE
 - P PRIORITY
 - R ROUTINE
- Prosigns that identify portions of a transmission:

- AA All after
- AB. All before
- WA Word after
- WB Word before
- Ending prosigns:
 - K. Go ahead; or, this is the end of my transmission to you and a response is invited.
 - A R . . . : . . . End of transmission; no receipt required.
- Pause prosigns:
 - AS I must pause for a few seconds.
 - AS AR I must pause longer than a few seconds; will call you back.
- Separation prosigns:
 - BT Break. (Separates text of message from heading and ending.)
 - II (Written in messages as a short dash.) . . . Separative sign. (Used to separate certain elements of message headings. Not to be used as punctuation to represent a hyphen or dash in message texts.) Used in CW.
- Prosigns always followed by one or more call signs and/or address groups:
 - DE From (in call).
 - FM Originator's sign.
 - TO The addressee designations immediately following are addressed for action.
 - INFO The addressee designations immediately following are addressed for information.
 - XMT Exempt. (Used to exempt addressees from a collective call or address.)

- Prosigns used in transmission instructions of a message:

T Transmit this message to all addressees or to the addressee designations immediately following.

G Repeat this entire transmission back to me exactly as received.

F Do not answer.

- Group count prosigns:

GR (plus numerals) Group count.

GRNC The groups in this message have not been counted.

- Prosigns used with the Executive Method:

IX Action on the message or signal that follows is to be carried out upon receipt of "EXECUTE." IX plus 5-second dash. "EXECUTE"—Carry out the direction of the message or signal to which this applies.

- General:

AA Unknown station.

B More to follow.

C Correct.

EEEEEEEE. Error (At least eight Es).

EEEEEEEE

AR This transmission is in error. Disregard it.

HMHMHM. . . . Emergency silence sign.

IMI Repeat.

INT Interrogative.

J Verify with originator and repeat.

NO Station serial number.

R I received your last transmission satisfactorily.

MESSAGE USER RESPONSIBILITIES

A message user is any individual authorized to draft, release, or process electronically transmitted messages. There are certain responsibilities associated with the origination of a message. These responsibilities are separate and distinct and concern the following parties:

- Originator;
- Drafter; and
- Releaser.

Occasionally, the responsibilities may overlap, especially if one person is serving a dual capacity. For example, communications officers may occasionally draft and release messages, thus making them both drafters and releasers.

ORIGINATOR

The originator is the authority (command or activity) in whose name the message is sent. The originator is presumed to be the commanding officer of the command or activity. Most often, the originator and the releaser are one and the same.

In some cases, the drafter, releaser, and originator are all the same person. For example, if the commanding officer drafts a message for transmission, he or she is the drafter as well as the releasing authority for the activity in whose name the message is sent.

DRAFTER

The drafter the person who actually composes the message. According to NTP 3, the drafter is responsible for:

- Properly addressing the message and using PLAs correctly;
- Using clear, concise composition;
- Selecting the precedence;
- Ensuring the proper format;
- Assigning the proper classification; and
- Ensuring the application of proper downgrading and declassification instructions to classified messages, except those containing Restricted Data or Formerly Restricted Data.

RELEASER

The releaser is a properly designated individual authorized to release messages for transmission in the name of the command or activity. The releasing individual ensures that the drafter has complied with the requirements contained in NTP 3. In addition to validating the contents of the message, the signature of the releaser affirms compliance with message drafting instructions. The signature of the releaser authorizes the message for transmission.

After a message has been properly released, it is delivered to the telecommunications center (TCC) for transmission. The DTG is normally assigned at the TCC. Proper transmission, receipting, and filing procedures are done by the communications personnel.

An important point to remember about the DTG is that it is assigned for identification and file purposes only. It is not used to compute message processing time.

VERIFICATION OF MESSAGES

Before your message is sent, someone at the comm center will check or verify that it is ready for transmission. For your part in this process, check the message for completeness and accuracy and ensure that it has been properly released. Ensure that the PLAs are written according to the MAD. If the message is classified, be sure it has downgrading instructions at the end of the text. Finally, check the precedence, and note if any special-handling procedures are required.

MESSAGE FORMAT

General administrative (GENADMIN) is the format used for most narrative messages. The exceptions are narrative messages for which a publication, instruction, or other directive requires a different format. In our discussion, we will be using the GENADMIN format.

There are other formats for special-purpose messages. These messages include casualty reports (CASREPs), movement reports (MOVREPs), and Status of Resources and Training System (SORTS). Instructions for preparing these messages are found in appropriate publications or instructions, such as naval warfare publications (NWP).

MESSAGE TEXT FORMAT (MTF)

The unique message identifier (MSGID), GENADMIN, distinguishes this message format from all other formatted messages. This distinction cues computer processing to the prescribed sequence and repetition of allowable *sets* within the message. Figure 3-16 shows the basic GENADMIN message format.

A set is an ordered collection of information specifically arranged to be both human readable and machine processable. A set always begins with a set identifier, which is a word, an acronym, or abbreviation. The set identifier cues the human reader or automated processor as to the set content. MSGID is a set, which means "message identification."

A field is a discrete block of information within a set. Each field within a set begins with a field marker (/) and may contain only information specified by a set map. Each set map is identified by its set identifier (MSGID, for example) and prescribes field arrangement and content.

There are two kinds of sets in the GENADMIN message: **linear** and **free text**.

A linear set consists of a set identifier and one or more data fields presented in a horizontal manner. A set identifier begins the set at the left margin and is a word, an abbreviation, or acronym that is descriptive of the information contained in the set.

A free-text set consists of a set identifier, such as AMPN, followed by a field marker and a single unformatted narrative data field. This type of set is used to explain or amplify formatted information contained in one or more of the linear sets in the message; for example:

```
AMPN/.....// (Info about preceding set only)
NARR/.....// (Info about two or more preceding sets)
RMKS/.....// (Info about the entire message)
```

```
AMPN/REF IS LETTER FROM USCINCEAST 18AUG94
RMKS/REQUEST IMMEDIATE REPLY
```

A data field is the basic element of reported information and may be formatted or unformatted. All data fields in a linear set are formatted.

Field markers (slant symbol [/]) mark the start of each field. The set identifier is separated from the first data field by a field marker, and subsequent data fields are separated from each other by field markers. Field markers are NEVER used before a set identifier, after the last field on a line, or after the final field in a set. Nor can they be used within a linear data field. Since

UNCLAS (or appropriate classification)

SUBJ:

MSGID/GENADMIN/COMNAVCOMTELCOM//

RMKS/

1. (U)

....FREE.....

.....TEXT.....

.....AS.....

2. (U).....MUCH.....

.....AS.....

.....YOU.....

3. (U).....NEED.....//

DECL/OADR// (or other DECL instruction for classified messages)

NOTES:

- DECL/ SET NOT USED FOR UNCLAS MESSAGE
- WHEN YOU REFERENCE USMTFs, USE THE MESSAGE ID TYPE "SHORT TITLE" (MSGID) OF THE MESSAGE; for example,

REF/A/RRI/J6J/xxxxxxZxxx94

Figure 3-16.—Basic GENADMIN message format.

field markers have particular significance in the automatic processing of messages, they cannot be used within formatted data fields.

REFERENCES

A reference may be any message (voice or record), document, correspondence, meeting, or telephone conversation that is pertinent to the text of the message. Figure 3-17 shows examples of various types of references using the reference (REF) set.

If there are two or more references in a GENADMIN message, each reference uses an individual REF set and is serialized alphabetically.

The AMPN (amplification) line further explains one reference and immediately follows the REF set. The NARR (narrative) line further explains more than one reference and immediately follows the last REF set.

The RMKS (remarks) set (figure 3-16) is the main body of the free text portion of a GENADMIN message.

Textual paragraphs are numbered consecutively, and each number is followed by a period. No line of text can exceed 69 characters.

SUBJECT LINE MARKINGS

The subject line of a classified message must be marked with the appropriate classification symbol if the subject line contains classified information. If the subject line itself is unclassified, it must be so marked. For both cases, the appropriate security symbol is enclosed by parentheses (table 3-4) and follows the subject line.

Table 3-4.—Security Marking Symbols

CLASSIFICATION	MARKING SYMBOL
Unclassified	(U)
For Official Use Only	(FOUO)
Confidential	(C)
Secret	(S)
Top Secret	(TS)
Restricted Data	(RD)
Formerly Restricted Data	(FRD)

PARAGRAPH MARKINGS

The *Department of the Navy Information and Personnel Security Program Regulation*, OPNAVINST 5510.1 (Security Manual), requires that each paragraph and subparagraph of classified messages be marked to show the level of classification. If unclassified, the paragraph or subparagraph should be so marked.

DOWNGRADING AND DECLASSIFICATION MARKINGS

Downgrading and declassification markings are required on all classified messages except those containing Restricted Data (RD) or Formerly Restricted Data (FRD).

MESSAGE READDRESSALS

If you receive or send a message and later determine that another activity may need to act on or know about the information in the message, you can readdress the original message to that activity. If you receive a copy of a message as an “information addressee,” you can only readdress the original for information purposes.

Use a short form or long form, depending on how long ago the original message was sent. For both the short form and long form, you must:

- Fully identify the message you are readdressing;
- Enter the new addressee(s);
- Enter the original message originator;
- Include the original date-time group;
- Use the Process Sequence Number (PSN), if contained in the original message.

If the original message was sent within the last 60 days, use the short form to readdress it. Messages are held in the message center file for up to 60 days. On the short form, enter the *from*, *to*, and *information addressees* in the fields provided. Send the short form to the message center where it will be combined with the text of the original and then sent.

The short form readdress is always unclassified. However, it must state the classification of the readdressed message.

Messages over 60 days old are routinely deleted from the message center files. If the original message to be readdressed is more than 60 days old, use the long form. Enter the *from*, *to*, and *information addressees* in

CONFERENCE

REF/A/**CON**/CDR 82ND AB DIV/20SEP94

AMPN/AIRBORNE COMMANDERS CONFERENCE, FT BENNING GA//

MEETING

REF/A/**CON**/COMNAVWEPS CTR/02NOV93//

AMPN/JOINT ORDNANCE WORKING GROUP MEETING, DAHLGREN VA//

DISCUSSION/CONVERSATION (other than telephone)

REF/A/**CON**/CINCFOR/11MAR94

AMPN/BETWEEN MAJ SMITH CINCFOR(FCJ3J) AND CDR JONES

CINCLANT(J36)//

TELEPHONE

REF/A/**TEL**/SPAWARS/08DEC93

AMPN/REF/A IS TELCON BETWEEN SPAWARS/LCDR SMITH AND CNO/CDR
JONES//

DOCUMENT (Pub, Instruction, Reg., and so forth.)

REF/A/**DOC**/JCS J7/15APR94//

AMPN/JCS PUB 1-01 CHAP II, PARA 3.//

REF/A/**DOC**/DOD/01SEP94

AMPN/DIR 5000.1, SUBJECT: MAJOR AND NON-MAJOR DEFENSE

ACQUISITION PROGRAMS, PG 3, PARA D.3.//

REF/A/**DOC**/JCS/07JAN93//

AMPN/JCS MOP 160, PG 6, PARA D (1)//

Figure 3-17.—Examples of references.

LETTER (For example, correspondence, memo, NAVGRAMs)

REF/A/**LTR**/JCS J7/18JUN94//

AMPN/TASKING LETTER TO GPO, SUBJ: PRINTING SERVICES SER J7/178//

REF/A/**LTR**/JCS J3/25SEP94//

AMPN/MEMO FOR DISTRIBUTION SER J3-202-93//

REF/A/**LTR**/JCS J6/19AUG94//

AMPN/MEMO FOR DIRECTOR, JTC3A. SUBJ: C3 INITIATIVES SER
J6-568-88//

RECORD MESSAGES (other than USMTF messages)

REF/A/**RMG**/JCS J3(JOD)/240700ZMAR94//

AMPN/ALERT ORDER: OPERATION FULL BORE (U)//

REF/A/**RMG**/JCS J7-JETD/071818ZDEC94//00194//

REF/B/**RMG**/JCS J7-JETD/071326ZJAN94//00294//

NARR/REFS ARE PREVIOUS INTELLIGENCE SITUATION MSGS FOR EXERCISE
PROUD SCOUT 93 (U)//

VOICE MESSAGE (other than USMTF voice messages)

REF/A/**VMG**/PC188/181800ZMAY94//

AMPN/AIRCRAFT POSITION REPORT TO LOS ANGELES CENTER//

REF/A/**VMG**/PAN AM 845/050615ZMAR94//

AMPN/MAYDAY RECEIVED BY USS ENTERPRISE ON 121.5 MHZ//

Figure 3-17.—Examples of references—Continued.

the fields provided. Unlike the short form, you retype the entire message. Classify the long form the same as the original message.

When a sectionalized message is readdressed, each section of the message must be readdressed separately. The headerlines and addressees must be the same on each readdress. The PSN must match that of the section being readdressed, but the respective section number is omitted. Each section of the readdressed message should have the same date-time group.

The precedence of the readdress message maybe lower than, the same as, or higher than that of the original message when deemed operationally imperative by the readdress authority.

General formatting instructions and preparation guidance are available in NTP 3. Message readdress procedures may vary slightly at different TCCs. You may verify the required procedure through the local TCC.

ACCOUNTABILITY AND CONTROL OF CLASSIFIED INFORMATION

One of your primary responsibilities is to ensure that classified information is not revealed to anyone who does not have a need to know. Security is a means, not an end. Regulations that govern security of classified information do not guarantee protection, nor do they attempt to meet every conceivable situation. Therefore, the accountability and control procedures used to protect classified information must be effective if their objective of protecting this information is to be realized.

The following procedures and requirements are written in somewhat formal language. This is because accountability for classified material is taken very seriously.

ACCOUNTABILITY FOR TOP SECRET

The command Top Secret control officer, assisted by designated Top Secret control assistants, is responsible for receiving and distributing Top Secret documents and for maintaining accountability registers. All Top Secret documents originated or received by a command for which the Top Secret control officer is responsible must be listed in the command's accountability register. The register must completely identify the Top Secret document, including changes, show the number of copies, and give the disposition of each copy. The register must be retained for 5 years

after the documents are transferred, downgraded, or destroyed.

All Top Secret documents and equipment are serially numbered at the time of origination. Additionally, each document is marked to indicate its copy number in the following manner:

"Copy No. _____ of _____ copies."

Exceptions to this rule are allowed for publications containing a distribution list by copy number and for mass-produced reproductions when costs of copy numbering would be prohibitive. In the latter case, adequate and readily available documentation is maintained, indicating the total number of copies produced as well as the recipients of the copies. Copy numbers may be applied to Top Secret microfilm by the use of adhesive stickers, adhesive stripping of headers, pin punching or marking pins.

If more than one microform is required in the microreduction of a Top Secret document or group of documents, the number of microforms used is indicated. There is, at this time, no standardized technique for reflecting the number of microforms used; any local technique that accurately provides the information is acceptable. For Top Secret microfiche, the data is indicated in the lower right portion of the header.

Top Secret documents must contain a list of effective pages, which includes a Record of Page Checks. If this is impractical, as in correspondence or messages, the pages should be numbered as follows:

"Page _____ of _____ pages."

Top Secret documents must be page-checked for completeness and accuracy by the Top Secret control officer on initial receipt and when a complete change has been entered. The change residue, including pages removed, must also be page-checked prior to destruction. Page checks by the relieving officer, upon relief of the Top Secret control officer as custodian, are only required when specifically called for by letter of promulgation. Page checks are not required for documents that are received by a distribution point for transshipment. Page checks of these documents will be conducted by receiving commands.

Top Secret documents must be physically sighted or accounted for by examination of written evidence of proper disposition, such as certificate of destruction, transfer, receipt, and so forth, at least annually, and more frequently when circumstances warrant. At the same time, each Top Secret document must be audited to

determine its completeness and accuracy. As an exception, repositories, libraries, or activities that store large volumes of classified material may limit their annual inventory to all documents and material to which access has been given in the past 12 months, and 10 percent of the remaining inventory.

Retention of Top Secret documents must be kept to the minimum consistent with current requirements. Nonrecord Top Secret documents should be destroyed as soon as their intended purpose has been served. When Top Secret is destroyed, a record of destruction must be prepared, identifying the material destroyed and the two officials who witnessed the destruction. Top Secret record documents that cannot be destroyed must be reevaluated and, when appropriate, downgraded, declassified, or retired to designated records centers.

Top Secret material must be accounted for by a continuous chain of receipts. Hand-to-hand transfer with signed receipts is required for internal distribution of Top Secret, with a record kept of each individual to whom the information is disclosed.

Top Secret message traffic, handled by naval communication stations for relay or broadcast delivery only or received by an afloat command via the fleet broadcast but not addressed to that command, must be accounted for and destroyed according to NTP 4 (NOTAL).

CONTROL OF TOP SECRET

Commands must maintain a disclosure record for each Top Secret document, attached to the document, that contains the document title, names of all individuals, including stenographic and clerical personnel, who have been afforded access to information contained in the document, and the date(s) of access. Individuals within an activity who may have had access to containers in which Top Secret information is stored, or who regularly administratively handled a large volume of such information need not be included in the disclosure records. These personnel are considered identifiable by roster as having had access to such information on any given date. Disclosure records must be retained for 5 years after the documents are transferred, downgraded, or destroyed. OPNAV Form 5511/13 (Record of Disclosure) maybe used for this purpose.

There are two exceptions to the requirement for attaching the disclosure record form:

- Mailrooms, file rooms, communication and message centers, and printing and reproduction activities that process large volumes of Top Secret material usually do not use the disclosure record form if access to the area is limited to permanently assigned personnel and if these individuals are identifiable by roster as having access on any given date.
- Oral discussions within committees or conferences involving the disclosure of Top Secret information are also subject to accounting requirements. This requirement is considered satisfied if the minutes of the conference or meeting show a summary of the information discussed or furnished and a complete listing of all persons present.

Note that the disclosure record form is used in addition to the continuous receipt system required for Top Secret material that we discussed earlier in this chapter.

The control of Top Secret information is maintained by the Top Secret control officer (if one is designated), or the command security manager. You may be required to assist either of them.

ACCOUNTING FOR SECRET

Administrative procedures must be established for managing Secret material, and must include records of material

- originated or received by the command;
- distributed or routed to components of, or activities within, the command; and,
- disposed of by transfer of custody or destruction.

The RECORD may be a mail log, a communications log, file of route slips, serial file or other administrative record. Accounting for Secret material may or may not be centralized. Records must be retained for at least 2 years.

CONTROL OF SECRET

The control procedures for Secret material must be determined by the practical balance of security and operating efficiency. Signed receipts are not required for material distributed or routed within the command. Receipts are required when Secret material accountability is transferred from one custodian to another, whether or not within the command.

Normally, Secret material must be hand delivered from one accountable person to another within a command.

ACCOUNTING FOR AND CONTROL OF CONFIDENTIAL

Procedures for protecting Confidential information are less stringent than those for Secret information. In addition, only one witness is required for destruction. There is no requirement to maintain records of receipt, distribution, or disposition of Confidential material. Administrative provisions are required, however, to protect Confidential information from unauthorized disclosure by access control and compliance with the regulations on marking, storage, transmission, and destruction.

ACCOUNTING FOR AND CONTROL OF CODE WORDS

The Joint Chiefs of Staff allocate blocks of code word material to agencies of the Department of Defense. Within the Department of the Navy, only the Chief of Naval Operations, CINCLANTFLT, CINCPACFLT, and CINCUSNAVEUR may assign code words. The CNO annually accounts to JCS for code words assigned to the Department of the Navy. Strict accountability, therefore, must be maintained over the use of code words. The CNO should be promptly informed whenever a code word is activated or canceled. Meanings of words should be sent separately from activation notices whenever possible.

ACCOUNTING FOR AND CONTROL OF WORKING PAPERS

Working papers are documents and material accumulated or created in the preparation of finished documents or material. Working papers containing classified information must be

- dated when created;
- marked on each page with the highest classification of any information they contain;
- protected according to the classification assigned; and
- destroyed, by authorized means, when no longer needed.

The accounting, control, and marking requirement prescribed for a finished document must be followed

when working papers contain Top Secret information or are

- released by the originator outside the command, transmitted electrically or through message center channels within the command;
- filed permanently; or
- retained more than 90 days from date of origin.

Refer to chapter 10 of OPNAVINST 5510.1 (Security Manual) when requesting a waiver of accountability, control, and marking for working papers containing Top Secret information.

CLASSIFIED MICROFORM

The policy and procedures for controlling and safeguarding classified documents apply equally to classified microforms.

CLASSIFIED AIS MATERIALS

Classified AIS storage media and output must be controlled and safeguarded in a manner equivalent to that provided classified documents of a similar classification. Specific procedures are contained in the *Department of the Navy Automatic Data Processing Security Program*, OPNAVINST 5239.1.

A deck of classified accounting machine cards may be considered a single document. Only the first and last cards need classification markings as prescribed for other classified documents of the same classification. An additional card, however, must be added to identify the contents of the deck and the highest classification involved. Cards removed for separate processing or use and not immediately returned to the deck after processing must be protected to prevent compromise of any classified information they contain. Cards must be marked individually as prescribed for any classified document.

CUSTODY OF CLASSIFIED MATERIAL

Classified material must not be removed from the physical confines of a command without the knowledge and approval of the commanding officer or his or her authorized representative. When classified material is removed, a complete list is prepared, signed by the individual removing the material, and appropriately filed until the material is returned.

This procedure is apart from the normal procedure of transmission discussed later in this chapter.

CARE DURING WORKING HOURS

Every IS must take the necessary precautions to prevent access to classified information by unauthorized persons. These precautions include:

- When removed from storage for working purposes, classified documents must be kept under constant surveillance or face down or covered when not in use.
- Preliminary drafts, carbon sheets, plates, stencils, notes, work sheets, and all similar items containing classified information require special precautions. They must be either destroyed immediately after they have served their purpose or given the same classification and safeguarded in the same manner as the classified material produced from them.
- Typewriter ribbons used in typing classified material must be protected in the same manner as the highest level of classification for which they have been used. Fabric typewriter ribbons may be considered as unclassified when both the upper and lower sections have been recycled through the machine five times in the course of regular typing. Ribbons that are classified must be destroyed as classified waste.

CARE AFTER WORKING HOURS

All classified material must be locked in an approved security container. A system of security checks at the close of each working day is the best method to ensure that all classified material held is properly protected. Whether your watch section is being relieved by the oncoming watch or you are securing an office space, you should make an inspection to ensure as a minimum that:

- All classified material is properly stored;
- Burn bags are properly stored or destroyed;
- Wastebaskets do not contain classified material; and
- Classified notes, carbon paper, carbon and plastic typewriter ribbons, rough drafts, and similar papers have been properly stored or destroyed. As a matter of routine, such items

should be placed in burn bags immediately after they have served their purpose.

When classified material is secured in security containers, the dial of combination locks should be rotated at least four complete turns in the same direction.

Identification of the individual responsible for the contents of each container of classified material must be readily available. The individual responsible for a container will be contacted if it is found open after working hours.

TRANSMISSION

The term *transmission* refers to any movement of classified information or material from one place to another. Unless a specific kind of transportation is restricted, the means of transportation (car, bus, train, ship, or plane) is not particularly significant.

During transmission, classified information must either be in the custody of an appropriately cleared individual or an approved system or carrier.

The carrying of classified material across national borders is not permitted unless arrangements have been made that will preclude customs, postal, or other inspections. In addition, foreign carriers may not be used unless the United States (U.S.) escort has physical control of the classified material.

TOP SECRET

Transmission of Top Secret is allowed only by one of the following methods:

- The Defense Courier Service (DCS);
- The Department of State Courier System (if appropriate);
- Cleared and designated personnel traveling on a conveyance owned, controlled, or chartered by the government or cleared contractor;
- Cleared and designated U.S. military personnel or government civilian employees by surface transportation;
- Cleared and designated U.S. military personnel or government civilian employees on scheduled commercial passenger aircraft within and between the United States and its territories, and Canada;

- Cleared and designated DOD contractor employees within and between the United States and its territories, provided the transmission has been authorized in writing by the appropriate contracting officer or a designated representative;
- A cryptographic system authorized by the Director, NSA, or through a protected distribution system designed and installed to meet the standards included in the National COMSEC and Emanations Security (EMSEC) Issuance System.

SECRET

Secret information must be transmitted only by these means:

- Any of the means approved for the transmission of Top Secret, except that Secret material (excluding sensitive compartmented information and COMSEC material) may be introduced into the DCS only when U.S. control of the material cannot otherwise be maintained.
- Appropriately cleared contractor employees within and between the United States and its territories. In other areas, appropriately cleared DOD contractor employees may transmit Secret material only when the material is not transported across international borders, time limitations do not permit the use of U.S. Government channels, the transmission is begun and completed during normal duty hours of the same day, and surface means only are used.
- United States Postal Service registered mail within and between the United States and its territories.
- United States Postal Service registered mail through Army, Navy, or Air Force Postal Service facilities, outside the United States and its territories, provided that the material does not pass out of United States citizen control and does not pass through a foreign postal system or any foreign inspection.
- United States Postal Service and Canadian registered mail with registered mail receipt between United States Government and/or Canadian Government installations in the United States and Canada.

- Other carriers under escort of appropriately cleared personnel. Carriers included are government and government contract vehicles, aircraft, ships of the United States Navy, civil service-manned United States naval ships, and ships of U.S. registry. Appropriately cleared operators of vehicles, officers of ships, or pilots of aircraft who are United States citizens maybe designated as escorts provided the control and surveillance of the carrier is maintained on a 24-hour basis. The escort must protect the shipment at all times, through personal observation or authorized storage to prevent inspection, tampering, pilferage, or unauthorized access until delivered to the consignee. Observation of the shipment, however, is not required during the period it is stored in an aircraft or ship in connection with flight or sea transit, provided the shipment is loaded into a compartment not accessible to any unauthorized persons, or loaded in specialized containers, including closed cargo containers. Use of specialized containers aboard aircraft requires that:

- Appropriately cleared personnel maintain observation of the material while it is being loaded aboard the aircraft and that observation of the aircraft continues until it is airborne.
- Observation by appropriately cleared personnel is maintained at the destination while the material is being off-loaded and at any intermediate stops. Observation should be continuous until custody of the material is assumed by appropriately cleared personnel.

- Electrical means over approved communication circuits to which safeguards have been applied to protect unencrypted classified information. Commanding officers are authorized to certify as "approved circuits" any circuits that meet the criteria of *Communications Instructions—Security (U)*, ACP 122, for the transmission of Secret and Confidential information in the clear. On request, COMNAVSECGRU will provide guidance in cases not covered by ACP 122.

CONFIDENTIAL

Confidential material may be transmitted by any means allowed for Secret material. Requirements for

transmitting Confidential material through the United States Postal Service are listed in chapter 15 of the Security Manual.

RESTRICTED DATA

Restricted Data documents may be transmitted in the same manner as other material of the same security classification.

COMSEC MATERIAL

COMSEC material must be transmitted according to *Communications Security Material System (CMS) Policy and Procedures Manual, CMS 1*.

Information on the transmission of Confidential, classified material to foreign governments, and consignor-consignee responsibility for shipment of bulky material is covered in chapter 15 of the Security Manual.

PREPARATION FOR TRANSMISSION AND SHIPMENT

Classified material must be properly prepared for transmission to protect it from unauthorized disclosure. When classified material is transmitted, it must be enclosed in two opaque, sealed envelopes or similar wrappings, where size permits. Procedures are listed below:

- Classified written material must be folded or packed so the text will not be in direct contact with the inner envelope or container.
- The inner envelope or container must show the address of the receiving activity, highest classification of the material enclosed including, where appropriate, the "Restricted Data" marking and any special instructions. It must be carefully sealed to minimize the possibility of access without leaving evidence of tampering. The receipt required for Top Secret and Secret material must be attached.
- The outer cover must not bear a classification marking, a listing of the contents showing classified information, or any other unusual data or marks that might invite special attention to the fact that the contents are classified. The outer cover of Confidential material being transmitted by United States Postal Service First-Class Mail must be marked "FIRST CLASS" and be

endorsed, "Postmaster: Do Not Forward, Return to Sender."

Whenever the classified material being transmitted is too large to prepare as described above, it must be enclosed in two opaque, sealed containers, such as boxes or heavy wrappings, or prepared as follows:

- If the classified material is an internal component of a packageable item of equipment, the outside shell or body may be considered as the inner enclosure.
- If the classified material is an inaccessible internal component of a bulky item of equipment that is not reasonably packageable, such as a missile, the outside or body of the item may be considered as the outer enclosure provided the shell or body is not classified.
- If the classified material is an item of equipment that is not reasonably packageable and the shell or body is classified, it must be draped with an opaque covering that will conceal all classified features. The coverings must be capable of being secured to prevent inadvertent exposure of the item.
- Specialized shipping containers, including closed cargo transporters, may be used. The container is then considered to be the outer wrapping or cover.

Material used for packaging must have enough strength and durability to provide security protection while in transit, to prevent items from breaking out of the container, and to help detect any tampering with the container. The wrappings must conceal all classified characteristics. Activities must provide for the stocking of several sizes of cardboard containers and corrugated paper. Packages must be sealed with tape that will retain the impression of any postal stamp. Bulky packages must be inspected to determine whether the material is suitable for mailing or whether it should be transmitted by other approved means.

Closed and locked compartments or vehicles must be used for shipments of classified material except when another method is authorized by the consignor. In any event, individual packages weighing less than 200 pounds gross may be shipped only in a closed vehicle.

During transfers at sea, classified material must be placed in weighted bags to ensure prompt sinking in case of loss into the sea during transfer.

ADDRESSEES

Classified material must be addressed to a recognized activity and not to an individual. Office code numbers or office or division titles, such as "Training Division" or similar aids in expediting internal routing, may be used in addition to the organization address.

For correct mailing addresses, consult the *Standard Navy Distribution List (SNDL)*, OPNAV PO9B2-105. Part 1 contains the official list of fleet and mobile units. Part 2 contains the official list of shore activities.

The inner envelope or container must show the address of the receiving activity.

An outer envelope or container must show the complete and correct address and the return address of the sender. However, the address may be omitted from the outer enclosure for shipment in full truckload or carload lots.

Care must be taken to ensure that classified material intended only for the U.S. elements of international staffs or other organizations is addressed specifically to those elements and that the correct address for classified mail is used for overseas locations.

Receipt System

As we mentioned earlier, Top Secret material is covered by a continuous chain of receipts. Secret material, as a minimum, is covered by a receipt between commands and other authorized addressees. Receipts for Confidential material are not required except when transmitted to a foreign government (including embassies in the U.S.). The receipt form is attached to or enclosed in the inner cover.

Postcard receipt forms, such as the Record of Receipt (OPNAV Form 5511/10), or a computer-generated receipt may be used for this purpose. Receipts should be unclassified and contain only the information necessary to identify the material being transmitted. Receipts are retained for a minimum of 2 years.

In those instances where a flyleaf (page check) form is used with classified publications, the postcard receipt is not required.

STORAGE

Classified material is stored only at locations where facilities are available for its secure storage or

protection and where unauthorized personnel are prevented from gaining access to the material. To the extent possible, the areas in which classified information is stored will be limited.

Valuables, such as money, jewels, precious metals, and narcotics, may not be stored in containers used for the storage of classified material.

Restricted Data is stored according to the storage requirements for the classification assigned.

TOP SECRET

Top Secret material must be stored in:

- A Class A or B vault, a strongroom that meets the standards prescribed in exhibit 14B of the Security Manual, or a General Services Administration-approved security container. When located in a building, structural enclosure, or other area not under U.S. Government control, the vault, strongroom, or security container must be protected by an alarm system or be guarded by U.S. citizens during nonoperating hours.
- An alarmed area, provided such facilities afford protection equal to or better than those prescribed above.

SECRET AND CONFIDENTIAL

Secret and Confidential material maybe stored in the manner authorized for Top Secret, in a Class B vault, a vault-type room, strongroom, or secure storage room that has been approved for storage of material of these classifications.

DISPOSITION OF CLASSIFIED MATERIAL

Procedures for forwarding documents to the naval archives or GSA Federal records centers are established by the Secretary of the Navy. Classified documents forwarded for storage are safeguarded according to their classification categories. The procedures for transferring records are defined in SECNAVINST 5212.5. Extra copies and nonrecord material should be destroyed after their period of usefulness has ended.

When military or civilian personnel are separated from the Department of the Navy, they must turn in all classified material they hold to the source from which they received it, to their commanding officer, or to the nearest naval command, as appropriate, before they receive their final orders or separation papers.

A person being relieved must deliver to his or her successor all classified material of the command within his or her custody. Receipts should be completed, covering, as a minimum, all Top Secret material.

In the event of death or desertion or when a person is declared "missing," the commanding officer, in disposing of the personal effects, must ensure that they contain no classified material. Material not recovered or not known to have been destroyed must be reported as a possible compromise.

Classified material not required by a command should not be allowed to accumulate. It should be either destroyed or sent to storage at a Federal records center or other official depository.

DESTRUCTION OF CLASSIFIED MATERIAL

Classified material that is no longer required should not be allowed to accumulate. Destruction of superseded and obsolete classified materials that have served their purpose is termed *routine destruction*.

ROUTINE DESTRUCTION

There are specific directives that authorize the routine destruction of publications, message files, and crypto materials. As an Intelligence Specialist, you should study these directives carefully so that you may comply with them properly. Additionally, publications often contain destruction requirements in their letter of promulgation. Other materials, such as classified rough drafts, work sheets, and similar items, should be destroyed periodically to prevent their accumulation.

Top Secret, Secret, and Confidential material may be destroyed by burning, pulping, pulverizing, or shredding. Destruction must be complete, so that reconstruction of the material is impossible. The most efficient method of destroying combustible material is by burning.

DESTRUCTION PROCEDURES AND REPORTS

Top Secret and Secret material must be destroyed by two witnessing officials. Persons performing any destruction must have a clearance level equal to or higher than that of the material being destroyed. Destruction must be recorded on a record that provides for complete identification of the material being destroyed. Destruction records must include the number of copies destroyed, date of destruction, and the

names of personnel completing the destruction. These records are maintained for 2 years.

Confidential material and classified waste are destroyed by authorized means. Personnel performing destruction should hold an appropriate clearance and are not required to record the destruction.

If the material has been placed in burn bags for central disposal, the destruction record must be signed by the witnessing officials at the time the material is placed in the burn bags. Records of destruction must be retained for 2 years.

All burn bags must be given the same protection as the highest classification of material in them until they are destroyed. Since several burn bags may accumulate for burning, it is important to keep an accurate record of the number of bags to be burned. Burn bags must be numbered serially. A record must be kept of all subsequent handling until the bags are destroyed.

Burning

As an Intelligence Specialist, you will probably assist in the burning of classified material. Every member of a burn detail must know exactly what is to be burned and should double-check burn material against an inventory list before the material is burned.

To provide for accountability of the burn bags, the supervisor of a burn detail must be sure that the bags are numbered (or counted) before they are removed from the workspaces. The supervisor of a burn detail must have either a log or checkoff list that lists the number of bags to be burned. At the destruction site, each bag should be checked off the list as it is destroyed in the presence of the witnessing officials.

To ensure the complete destruction of bound publications, the pages must be torn apart and crumpled before they are placed in bags. All material must be watched until it is completely consumed. The ashes must be broken up and scattered so that no scraps escape destruction.

Shredding

Crosscut shredding machines are relatively quiet and may be used aboard ships where incinerator facilities are not available. Crosscut shredders are replacing incinerators in many areas where burning is not allowed because of the Clean Air Act. Crosscut shredding machines must reduce classified material to shreds no greater than 3/64 inch wide by 1/2 inch long. Crosscut shredding suffices as complete destruction of

classified material, and the residue may be handled as unclassified material with the exception of some COMSEC material. Not all crosscut shredders are suitable for destroying microfiche, so make sure the one you are using has that capability before attempting to shred microfiche.

Pulverizing and Disintegrating

Pulverizers and disintegrators designed for destroying classified material are usually too noisy and dusty for office use unless they are installed in a noise- and dust-proof enclosure. Some pulverizers and disintegrators are designed to destroy paper products only. Others are designed to destroy film, typewriter ribbons, photographs, and other material.

Jettisoning or Sinking

Material to be jettisoned during emergency destruction must be placed in weighted bags. The sea depth should be 1,000 fathoms or more. However, if the water depth is less than 1,000 fathoms, the material should still be jettisoned to prevent easy recovery.

EMERGENCY PLANS

Emergency plans provide for the protection, removal, or destruction of classified material. Commands holding classified material must develop an emergency plan to fit their needs. The primary requirement of an emergency plan is that it adequately provide for the rapid and complete destruction of the classified material. Emergency plans must cover three types of emergencies:

- Natural disasters, such as hurricanes;
- Civil disturbances, such as rioting; and
- Enemy action.

Emergency plans should provide for the protection of classified material in a manner that will minimize the risk of loss of life or injury to personnel.

For destruction, the command's emergency plan must do the following:

- Emphasize procedures and methods of destruction, including the place and destruction equipment required;
- Clearly identify the exact location of all classified material;
- Prioritize material for destruction; and

- Assign personnel, by billet, areas of responsibility for destruction.

Priorities

When the emergency plan is implemented, priority of destruction is based on the potential effect on national security should the material fall into hostile hands. COMSEC material is destroyed first. The priorities for emergency destruction are as follows:

- **FIRST PRIORITY**— Top Secret COMSEC material and classified components of equipment and all other Top Secret material;
- **SECOND PRIORITY**— Secret COMSEC material and all other Secret material;
- **THIRD PRIORITY**— Confidential COMSEC material and all other Confidential material.

After you have destroyed the classified for which you are responsible, you should destroy any unclassified equipment that could be of use to an enemy. You should also destroy pertinent technical, descriptive, and operating instructions.

Fire Plans

In addition to an emergency plan, a plan of action in the event of fire is also required. As with an emergency plan, it is important that all communications personnel familiarize themselves with their command fire plan. Normally, the fire plan provides for the following:

- Local fire-fighting apparatus and personnel to operate the equipment;
- Evacuation of the area, including a decision of whether to store classified material or remove it from the area; and
- Admitting outside fire fighters into the area.

Precautionary Actions

Precautionary destruction reduces the amount of classified material on hand in case emergency destruction later becomes necessary. Destruction priorities remain the same during precautionary destruction. However, when precautionary destruction is held, material essential to communications must not be destroyed. For example, communications operating procedures and publications that are to become effective in the near future should not be destroyed.

Communications operating procedures that are already effective, necessary, and being used should also not be destroyed.

The following actions should be taken daily:

- All superseded material should be destroyed according to its prescribed time frame.
- Unneeded material should be returned to the issuing agencies.
- Material should be stored so that it is readily accessible for removal during destruction.

Contrary to widespread opinion, there is no security policy requiring destruction of unclassified messages. However, some message centers with high volumes of classified and unclassified message traffic may find it more efficient to destroy all messages and intermingled files as though they were classified. Under some circumstances, units operating in foreign ports or waters and commands situated in foreign countries may take

additional precautions in disposing of unclassified material.

SUMMARY

This chapter has introduced you to the various methods and procedures used to support and maintain an intelligence office. We discussed the procurement of supplies; maintaining office and audio-visual equipment; and the handling of correspondence, records, files, publications, and directives.

We covered the basic procedures for managing the Naval Warfare Publication Library. We also identified the classes and types of naval messages and the importance of using the proper procedures and guidelines in creating and handling them. And finally, we discussed the importance of security and how classified material is controlled, maintained, and destroyed.

CHAPTER 4

SECURITY

LEARNING OBJECTIVES

Upon completing this chapter you should be able to do the following:

- *Explain the primary purpose of the Information Security Program and terms associated with the program.*
 - *Describe the two types of security clearances and the procedures used to grant them.*
 - *Identify and describe the categories of classified information.*
 - *Describe the basic procedures used to mark components of classified documents.*
 - *Define and compare original classification authority and derivative classification authority.*
 - *Describe how dissemination of classified information is controlled.*
 - *Describe typical security violations and the procedures used to investigate them.*
 - *Identify typical ploys foreign agents use in attempts to subvert military personnel and methods to counter those ploys.*
 - *Describe the requirements and procedures for sanitizing classified materials and working spaces.*
 - *Describe the proper procedures for destroying classified media.*
-

The security of the United States in general, and of naval operations in particular, depends on the safeguarding of classified information. The Intelligence Specialist must be especially vigilant since the handling of classified material will be an everyday occurrence. In this chapter, we will discuss information that will prepare you to perform your duties efficiently in handling classified material.

INFORMATION SECURITY PROGRAM

The U.S. Information Security Program has a chain of responsibility that begins with the Secretary of Defense and extends down to individual users of classified information. The chain of responsibility for the Department of the Navy (DON) Information

Security Program starts with the Secretary of the Navy. The Secretary of the Navy is responsible to the Secretary of Defense for establishing and maintaining the Information Security Program and for complying with the directives on the protection of classified information. The basic directive is the *DOD Information Security Program Regulation*, DOD 5200. IR. It is implemented by the *Department of the Navy Information Security Program Regulation*, OPNAVINST 5510.1, which contains requirements levied by Executive orders, National Security Council directives, and public laws. These documents and other directives, including U.S. Navy Regulations and General Orders, make up the Information Security Program in the Department of the Navy.

Within the Navy, the Chief of Naval Operations (CNO) is responsible to the Secretary of the Navy for policies on the security of classified information. Under the CNO, the Director of Naval Intelligence, currently CNO (N2Z), is the official primarily responsible for seeing that the Navy's Information Security Program is effective and that it follows directives issued by higher authority. Commanding officers are responsible to CNO (N2Z) for carrying out the Information Security Program within their commands. The security manager, designated by the commanding officer as his or her direct representative in all matters affecting the security of classified information, is responsible for administration of the Information Security Program within his or her command. Finally, every individual who acquires access to classified information is responsible for protecting that information according to OPNAVINST 5510.1.

PURPOSE OF THE SECURITY PROGRAM

The purpose of the security program is to ensure that official DON information on national security is protected to whatever extent and time are required. The *Department of the Navy Information Security Program Regulation*, OPNAVINST 5510.1 (hereafter called the *Security Manual*), is the basis for identifying the information to be protected. It prescribes a progressive system for classification, downgrading, and declassification; prescribes safeguarding policies and procedures to be followed; and sets up a monitoring system to ensure the effectiveness of the program throughout the Navy.

The security program deals basically with the safeguarding of information that should not be allowed to fall into the hands of foreign governments or foreign nationals because of the danger that such information might be used to cause injury to the United States.

DEFINITIONS

To give you a clear understanding of certain terms used with security, a select list of terms and their definitions is presented below:

ACCESS— The ability and opportunity to obtain knowledge or possession of classified information. Access should be limited to the minimum number of persons who require the information in the normal course of their duties.

ALIEN— Any person who is not a citizen or a national of the United States. (See definition for United States National.)

CLASSIFICATION— The determination that official information requires, in the interest of national security, a specific degree of protection against unauthorized disclosure, coupled with a designation signifying that such a determination has been made.

CLASSIFICATION MANAGEMENT— A discipline which seeks to ensure that official information is classified only when necessary in the interest of national security, is properly identified, and is kept classified only as long as necessary.

CLASSIFIED INFORMATION— Official information that requires protection against unauthorized disclosure in the interest of national security and that has been classified according to the provisions of Executive Order 12356.

CLASSIFIED MATERIAL— Any matter, document, product, or substance on or in which classified information is recorded or maintained.

CLASSIFIER— One who either

- has the authority to determine that official information, not known by him or her to be already classified, requires a specific degree of protection against unauthorized disclosure. He or she will designate that information as Top Secret, Secret, or Confidential; or
- determines that official information, known by him or her to already be classified by the government, is Top Secret, Secret, or Confidential, and designates it accordingly.

CLEARANCE— An administrative determination by a designated authority that an individual is eligible for access to classified information of a specific classification category.

COMPROMISE— A security violation that has resulted in confirmed or suspected exposure of classified information or material to an unauthorized person. Compromise is either

- confirmed, with conclusive evidence that classified material was compromised; or
- suspected, when some evidence exists that classified material has been subjected to compromise.

CUSTODIAN— An individual who has possession of or is otherwise charged with the responsibility for safeguarding and accounting for classified information.

DECLASSIFICATION— The determination that classified information no longer requires, in the interests of national security, any degree of protection against unauthorized disclosure, coupled with the removal or cancellation of the classification designation.

DOCUMENT— Any recorded information, regardless of its physical form or characteristics. A document includes, without limitation, written or printed material; data processing cards and tapes; maps; charts; paintings; drawings; engravings; sketches; working notes and papers; reproductions of such things by any means or process; and sound, voice, or electronic recordings in any form.

DOWNGRADE— To determine that classified information requires, in the interest of national security, a lower degree of protection against unauthorized disclosure than currently provided, coupled with changing of the classification designation to reflect the lower degree of protection.

FORMERLY RESTRICTED DATA— Information removed from the Restricted Data category upon joint determination by the Atomic Energy Commission and the Department of Defense that such information relates primarily to the military use of atomic weapons and that such information can be adequately safeguarded as classified defense information. Such information is, however, treated the same as Restricted Data for purposes of foreign dissemination.

HANDLING— Preparation, processing, transmission, and custody of classified information.

IMMIGRANT ALIEN— Any person who has been lawfully admitted into the United States for permanent residence under an immigration visa.

INFORMATION— Knowledge that can be communicated by any means.

LONG TITLE— A descriptive word or phrase, consisting of a name or of several words, assigned by the preparing agency to identify the subject matter of a document or a type of device.

MARKING— The physical act of showing on classified material the assigned classification,

changes in classification, downgrading and declassification instructions, and any limitations on use of the material.

NEED TO KNOW— A determination made by a possessor of classified information that a prospective recipient, in the interest of national security, has a requirement for access to, knowledge of, or possession of the classified information in order to carry out official military or other governmental duties. Knowledge of, possession of, or access to classified information may not be afforded to any individual solely by virtue of the individual's office, position, or security clearance.

OFFICIAL INFORMATION— Information that is owned by, produced for or by, or is subject to the control of the United States Government.

ORIGINAL CLASSIFICATION— An initial determination that official information requires, in the interest of national security, a specific degree of protection against unauthorized disclosure coupled with a designation signifying that such a determination has been made.

ORIGINAL CLASSIFICATION AUTHORITY— The authority to make original classification judgments that is given specifically and in writing to an official and his or her designated assistant of the Government.

RESTRICTED DATA— All data (information) covering

- the design, manufacture, or use of atomic weapons;
- the production of special nuclear material; or
- the use of special nuclear material in the production of energy, but not to include data declassified or removed from the Restricted Data category according to Section 142 of the Atomic Energy Act.

SECURITY— A protected condition of classified information that prevents unauthorized persons from obtaining information of direct or indirect military value. This condition results from the establishment and maintenance of protective measures that ensure a state of inviolability from hostile acts or influences.

SECURITY VIOLATION— Any failure to comply with regulations relative to the security of classified material.

SENSITIVE COMPARTMENTED INFORMATION (SCI)— All information and materials bearing special intelligence community controls indicating restricted handling within intelligence collection programs and their end products. These controls are formal systems of restricted access established to protect the sensitive aspects of foreign intelligence programs.

SHORT TITLE— A brief, identifying combination of words, letters, or numbers applied to specific items of classified material.

TRANSMISSION— Any movement of classified material from one place to another.

UNITED STATES NATIONAL— A person born in an outlying possession of the United States on or after the date of formal acquisition of such possession; or

- a person born outside the United States and its outlying possessions of parents, both of whom are nationals, but not citizens of the United States, and have had a residence in the United States or one of its outlying possessions prior to the birth of such person; or
- a person of unknown parentage found in an outlying possession of the United States while under the age of 5 years, unless shown, prior to reaching the age of 21 years, not to have been born in such outlying possession. (For the purposes of this regulation, U.S. Nationals are included in the use of the term “U.S. citizens.”)

UNITED STATES AND ITS TERRITORIES— The 50 States; the District of Columbia; the Commonwealth of Puerto Rico; the Territories of Guam, American Samoa, and the Virgin Islands; the Trust Territory of the Pacific Islands; and the Possessions, Midway and Wake islands.

UPGRADE— A change of the classification designation of already classified information to a higher level based on a determination that the information requires, in the interest of national security, a higher degree of protection against unauthorized disclosure than that provided by its current classification designation.

PERSONNEL SECURITY INVESTIGATIONS (PSIs)

A security clearance is an administrative determination that an individual is eligible for access to

classified information at a specified level of classification. However, simply having a security clearance does not automatically authorize an individual access to classified information. *Authorization* for access to classified information is based on a separate determination, depending on whether an individual who has the proper security clearance also has a need for access to the information in the performance of his or her official duties. An individual may remain eligible for access even though his or her present position does not require access.

Clearance and access are documented on the Record of Investigation, Clearance and Access (OPNAV Form 5520/20) and placed in the individual's official personnel record.

TYPES OF CLEARANCES

Personnel security clearances are of two types—final and interim.

Final Clearance

A final security clearance is one that has been granted upon completion of the PSI requirements specified in chapter 21 of the Security Manual for the level of clearance involved.

Interim Clearance

An interim clearance is granted temporarily, pending the completion of full investigative requirements or revalidation of a security clearance upon an individual's transfer. Interim clearances are granted by commanding officers and are recorded on OPNAV 5520/20. An interim clearance is effective for a maximum of 6 months, unless extended by the commanding officer. As a condition of the interim clearance, the PSI required for a final clearance must be requested at the time the interim clearance is granted. A final clearance must be granted upon satisfactory completion of the PSI. Refer to chapter 23 of the *Security Manual* for complete information on the issuance of an interim clearance.

TYPES OF PSIs

There are six types of personnel security investigations:

Single Scope Background Investigation (SSBI);

Periodic Reinvestigation (PR);

- Secret Periodic Reinvestigation (SPR);
- National Agency Check (NAC);
- National Agency Check and Inquiry (NACI); and
- Special Investigative Inquiry (SII).

The requirements for each type of PSI, as well as detailed instructions for requesting personnel security investigations, are contained in chapter 21 of the *Security Manual*. Since all Intelligence Specialist personnel are required to have an SSBI for access to compartmented information, we will discuss some of the details for completing the necessary SSBI forms.

Single Scope Background Investigations (SSBIs)

The Department of the Navy Central Adjudication Facility (DON CAF) is the final approval authority for SSBIs and SSBI-Periodic Reinvestigation (PRs) for access to Sensitive Compartmented Information (SCI) on all naval personnel.

As part of the Operations Department aboard ship, you may be involved with preparing the necessary forms to request SSBIs. This may be necessary for Intelligence Specialists, and possibly cryptologic personnel, requiring access to SCI. You should establish and maintain an SSBI/SSBI-PR tickler system, if such a system has not already been established. For IS personnel needing an SSBI, you should prepare and forward an investigative SSBI-PR package according to instructions contained in chapter 21 of the *Security Manual*. This package must contain the following forms:

- DD Form 1879, Request for Personnel Security Investigation (original and two copies).
- FD Form 258, Applicant Fingerprint Card (two).
- SF Form 86, Questionnaire for National Security Positions (original and four copies).

Questions that pertain to the subject's spouse or other dependent and to each member of the subject's immediate family who is a foreign national, immigrant alien, or naturalized U.S. citizen are now part of the SF 86. Additional forms are no longer necessary.

When DON CAF completes and adjudicates the SSBI/SSBI-PR, it will forward a favorable determination by message or letter to the appropriate command so that a Top Secret clearance maybe granted or continued.

We will not discuss how the forms are filled out, the requirement for personal interviews before requesting an SSBI, or other details. For this information, refer to the instructions in chapter 21 of the *Security Manual*. Just remember, the process of conducting a Single Scope Background Investigation is involved and time-consuming, even if all the SSBI forms are submitted correctly. Inadvertent omissions and errors on the forms will cause delays in response time.

CATEGORIES OF CLASSIFIED INFORMATION

Official information or material that requires protection in the interests of national security is classified in one of three categories: Top Secret, Secret, or Confidential, depending on the degree of its significance to national security. No other categories may be used to identify official information or material as requiring protection in the interests of national security (except for a few specifically provided for by statute).

Now let's take a look at each of the categories. (In our discussion, the words "information" and "material" are synonymous.) We will also discuss the designation "For Official Use Only," since it is sometimes associated with the classified categories.

TOP SECRET

Top Secret is the designation that is applied only to information or material the unauthorized disclosure of which could reasonably be expected to cause exceptionally grave damage to the national security. Examples of "exceptionally grave damage" include:

- Armed hostilities against the United States or its allies.
- Disruption of foreign relations vitally affecting the national security.
- The compromise of vital national defense plans or complex cryptologic and communications intelligence systems.
- The revelation of sensitive intelligence operations.

- The disclosure of scientific or technological developments vital to national security.

SECRET

Secret is the designation that is applied only to information or material the unauthorized disclosure of which could reasonably be expected to cause serious damage to the national security. Examples of “serious damage” include:

- Disruption of foreign relations significantly affecting the national security.
- Significant impairment of a program or policy directly related to the national security.
- Revelation of significant military plans or intelligence operations.
- Compromise of significant scientific or technological developments relating to national security.

CONFIDENTIAL

Confidential is the designation that is applied only to information or material the unauthorized disclosure of which could reasonably be expected to cause damage to the national security. Examples of “damage” include:

- Revelation of the strength of ground, air, and naval forces in the United States and overseas areas.
- Revelation of performance characteristics, test data, design, and production data on U.S. weapon systems and munitions.

FOR OFFICIAL USE ONLY

“For Official Use Only” is NOT a category of classification, but is assigned to certain official information. This marking is not within the purview of the rules for safeguarding information in the interests of national security, but the information may require protection according to law or in the public interest. See the *Department of the Navy Freedom of Information Act (FOIA) Program*, SECNAVINST 5720.42, for guidance concerning use of “For Official Use Only” markings.

PREPARATION AND MARKING

Each document or other material is classified according to the importance of the information it contains or reveals. It is important to identify individual items of information that need protection. The classification of the document or material must be the classification that provides protection for the highest classified item of information.

The markings on classified material serve the following purposes:

- Record the proper classification;
- Inform recipients of the assigned classification;
- Indicate the level of protection required;
- Indicate the information that must be withheld from unauthorized persons;
- Provide a basis for derivative classification; and
- Assist in downgrading and declassification actions.

When material is assigned a classification category, the classification is immediately marked clearly and conspicuously on all its parts that contain classified information. When possible, the markings are red in color.

A document is not required to have a front cover or title, but it must have a first page. However, if it does have a cover or title page, in addition to a first page, the markings should be placed as shown in figure 4-1. The classification is centered top and bottom. The Restricted Data (RD) or Formerly Restricted Data (FRD) caveat (if appropriate) is placed at the lower right preceded by a “classified by” line. The downgrading/declassification notation is placed at the lower left for all classified documents that do not contain RD/FRD. Other warning notices are placed at the bottom center above the classification.

A back cover is not required. If it is used, only the classification should be placed top and bottom center. Other caveats and downgrading/declassification notations are not needed. If a back cover is not used, no classified text may appear on the back of the last page.

Each inside page of a classified document is normally marked top and bottom center with the highest overall classification of the document. This procedure

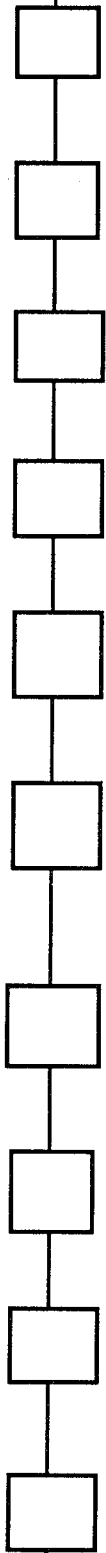

CONFIDENTIAL

UNCLASSIFIED TITLE (U)

(DATE)

SAMPLE

Commander, Naval Systems
Commander
Washington, DC 20362

Classified by OPNAVINST C5513.2B-62
Declassify on (Date) or (OADR)

CONFIDENTIAL

ISNP0015

NOTE: CONFIDENTIAL for training, otherwise unclassified
Figure 4-1.—Sample first or cover page.

SECRET

CHAPTER 5

FIRST ORDER HEADING (U)

Second Order Heading (U)

A. (U) Summary

1. (S) The classification marking of headings is illustrated above. Headings are marked according to their own classification and do not reflect the overall classification of the material which follows. Once a heading is identified by some means, it becomes a paragraph for marking purposes, e.g., "A. (U) Summary", as shown.

2. (U) The classification marking of paragraphs and subparagraphs is the same as for naval letter format (see appendix 8-C). The classification of the lead-in portion of a paragraph is shown at the beginning of the paragraph even though a subsequent subparagraph may reveal a higher level of classification.

a. (C) Subdivisions need not be marked if they do not express a complete thought. As an example, the following do not express complete thoughts:

- (1) Systematized digital projection.
- (2) Compatible organizational flexibility.
- (3) Synchronized transitional contingency.

b. (U) Individual paragraphs are classified according to the information they reveal.

c. (S-US ONLY) Control markings are indicated in full on the face of a document, that is, the front cover, or title page or first page. Additionally, each paragraph and subparagraph that contains information so caveated shall be marked with the abbreviated caveat following the classification symbol.

3. (U) The classification marking (top and bottom) should be in bold print and immediately distinguishable from the text.

SAMPLE

SECRET

NOTE: SECRET for training, otherwise unclassified

ISNP0016

Figure 4-2.—Sample interior page of a classified document.

is recommended because it's simpler, more efficient, and satisfies the security objective. See figure 4-2.

MARKING COMPONENTS

In some complex documents, the major components are likely to be used separately. In such cases, each major component must be marked as a separate document. The following are some examples of components that should be marked separately:

- Each annex, appendix, or similar component of a plan, program, or operations order;
- Attachments and appendices to a memorandum or letter; and
- Each major part of a report.

Titles and Subjects

Regardless of the overall classification of a classified document, the originator usually assigns to it an unclassified title or subject. The classification assigned to a *title, subject, abstract, index, term, or component*, for when it STANDS ALONE (outside of the document), is shown in parentheses immediately following the item, using one of the following notations: (U), (C), (S), (TS). When appropriate, the symbols (RD) or (FRD) are added for Restricted Data or Formerly Restricted Data. It is not necessary to assign one of these notations to the subject of a letter, endorsement, memorandum, or transmittal if a statement is included indicating that it is unclassified upon removal of the enclosures or basic material.

Referenced Material

When the title or subject of a classified document is referred to in another document, the classification of the title or subject must be shown. See the enclosure line of figure 4-3.

Paragraphs

Each paragraph of a classified document must be marked to indicate its classification. This requirement also applies to subparagraphs and stand-alone portions, sections, and parts. An exception to this rule is that subdivisions of a document or letter need not be marked if they do not express a complete thought (see the center of figure 4-2). The appropriate classification marking (the same as used for titles and subjects) is placed in parentheses to the left of the paragraph

immediately following the paragraph's letter or number designation (see figure 4-4) or preceding the first word if the paragraph is unnumbered.

Whenever paragraph markings are not practical, a statement must be included on the document or in its text identifying the parts of the document that are classified and their assigned classifications.

CLASSIFICATION AUTHORITY

Approximately 90 percent of the classified information produced by DON commands is derivative classification; that is, classification based on a classified source document or a security classification guide. To help you distinguish between original and derivative classification, we provide the following explanation:

ORIGINAL CLASSIFICATION AUTHORITY

Original classification is an initial determination that information requires, in the interests of national security, protection against unauthorized disclosure. For example, a missile program manager makes an original determination, while the missile is still on the drawing board, that the inventory objective (proposed number of missiles) requires a Confidential classification for a period of 6 years. The missile program security classification guide is issued with that original classification determination. The inventory objective itself may change from the originally planned number, but that does not change the fact that the inventory objective, as a result of an original classification action, is Confidential. Anytime a figure is put on paper showing the inventory objective, it is derivatively classified Confidential because of the original decision.

According to chapter 6 of the *Security Manual*, original determinations do not have to be issued in security classification guides if they do not pertain to a classified plan or program requiring a guide. These are isolated instances, however. Examples might be the origination of a new weapon concept that would require original classification determinations long before a program guide was developed or, in another case, the application of unclassified technology to a new military concept.



CONFIDENTIAL

DEPARTMENT OF THE NAVY
OFFICE OF THE CHIEF OF NAVAL OPERATIONS
WASHINGTON, D.C. 20350

5510 In reply refer to
Ser XXX/C123456
(Date)

CONFIDENTIAL--Unclassified upon removal of enclosures (1) and (3)

From: Chief of Naval Operations
To: Commander, Naval Systems Command

Subj: SECURITY CLASSIFICATION MARKINGS

Ref: (a) OPNAVINST 5510.1
(b) CNO Washington DC 012345Z Feb 82

Encl: (1) NAVSEA Report 1410, The New Torpedo (U)
(2) List of Attendees
(3) NRL Report 1592, The Principles of Radar (U)

SAMPLE

1. When titles or subjects of classified documents are included in the reference line, enclosure line or body of the letter, the classification of the title or subject follows, as shown on the enclosure line above. It is not necessary to show the classification of the reference or enclosure itself; however, each classified enclosure which must be removed before the letter of transmittal can be unclassified must be identified at the top, as shown.

2. Only the first page of an unclassified letter of transmittal carries classification markings. There would be no downgrading and declassification instructions on a letter of transmittal which is itself unclassified. If the letter of transmittal contains classified information, it will carry the appropriate downgrading and declassification instructions for the information it contains.

3. Intelligence control markings are typed out in full at the top, following the classification. If any enclosure contains Restricted Data, Formerly Restricted Data or Critical Nuclear Weapons Design Information, the words should be typed out after the classification at the top and the full warning notice placed at the bottom left. If the letter of transmittal contains information classified at the same level as the enclosure but does not, in itself, contain the information requiring the warning notice or intelligence control marking, words to the effect, "Warning notice (intelligence control marking) cancelled upon removal of enclosure (1)" should appear at the top.

R. R. GORENA
By direction

CONFIDENTIAL

ISNP0017

NOTE: CONFIDENTIAL FOR TRAINING, OTHERWISE UNCLASSIFIED

Figure 4-3.—Sample letter of transmittal.



SECRET

DEPARTMENT OF THE NAVY
OFFICE OF THE CHIEF OF NAVAL OPERATIONS
WASHINGTON, D.C. 20350

SAMPLE

IN REPLY REFER TO

5510
Ser XXX/S123456
(Date)

SECRET

From: Chief of Naval Operations
To: Recipients

Subj: PORTION MARKING (U)

1. (U) This is a sample of a fairly complex letter with multiple parts (paragraphs, subparagraphs, and a chart). It has been created for the purpose of demonstrating the proper method of applying portion classification markings in accordance with the requirements of OPNAVINST 5510.1. In this sample, paragraph 1 in its totality contains Secret information, but the lines of the opening paragraph do not, as indicated by "U" precursory marking.

a. (S) In continuing the graphic illustration of the proper techniques of applying portion classification markings, this subparagraph of the sample document contains information classified Secret as indicated by the "S" precursory marking.

(1) (S) Again, this subparagraph contains information classified Secret.

(a) (C) Every part of a classified document is to have portion classification markings applied. The text in this subparagraph contains information classified Confidential.

1. (S) The text in this subparagraph contains information that is Secret. Bear in mind that the objective of portion classification marking is to eliminate doubt as to which portions of a document contain or reveal classified information.

a. (U) This part of the sample document is unclassified as indicated by the "U" precursory marking.

b. (C) This part of the sample document is classified Confidential as indicated by the "C" precursory marking.

2. (U) This part contains no classified information.

Classified by OPNAVINST C5513.3A-17
Declassify on OADR

SECRET

ISNP0018

NOTE: SECRET FOR TRAINING, OTHERWISE UNCLASSIFIED

Figure 4-4.—Paragraph and portion markings.

DERIVATIVE CLASSIFICATION AUTHORITY

All classification decisions coming from the original determination are derivative classification actions. One element of originally classified information may generate thousands of derivatively classified documents. Using the missile program as an example again, the missile program manager originally classified the accuracy of the missile as Confidential. This accuracy information will appear in hundreds of documents during the lifetime of the missile, each one classified derivatively.

Derivative classification can be done by anyone who incorporates, paraphrases, restates, or generates in new form, information that is already classified. Derivative classification is most commonly done by marking material according to guidance from an original classification authority. Persons who apply derivative classifications must take care to determine whether their paraphrasing, restating, or summarizing of classified information has removed all or part of the basis for classification. They must also satisfy the following requirements:

- Respect original classification decisions;
- Verify the current level of classification of the information as far as practicable; and
- Carry forward to any newly created documents the previously assigned dates or events for declassification or a notation that the information cannot be automatically declassified without the approval of the originating agency.

Standard downgrading and declassification markings are covered in chapter 8 of the *Security Manual*. As an Intelligence Specialist, your responsibility extends only to the proper format and location of markings for classified correspondence and NOT the determination of security classification to be assigned. The security classification is the responsibility of the originator of the correspondence.

CONTROL OF DISSEMINATION

Organization commanders are responsible for controlling the dissemination of classified information originated or received by their commands. They are also responsible for issuing directives, as necessary, to prevent unauthorized dissemination of information under their control. The existence, nature, content, or

whereabouts of classified information must not be revealed needlessly.

Dissemination of classified information is limited to persons whose official military or other government duties require access in the interest of promoting national defense, and who have been properly cleared for access.

Responsibility for determining whether a person's official duties require him or her to possess or have access to classified information and whether the individual is authorized to receive it rests upon whoever has possession, knowledge, or control of the information, and NOT upon the person who receives the information.

RESTRICTED DATA OR FORMERLY RESTRICTED DATA

Material bearing the Restricted Data or Formerly Restricted Data warning notices (figure 4-5) may not be issued outside authorized channels without the permission of the originator or higher DOD authority.

For further information on clearances for access to and dissemination of Restricted Data or Formerly Restricted Data, see *Access to and Dissemination of Restricted Data*, DOD Directive 5210.2.

DISSEMINATION OF TOP SECRET MATERIAL

Top Secret material originated within the DOD must not be disseminated outside the DOD without the consent of the originating department or agency, or higher authority.

DISSEMINATION OF SECRET AND CONFIDENTIAL MATERIAL

Secret and Confidential material originated within the DOD may be disseminated to other departments and agencies of the executive branch of the government unless specifically prohibited by the originator.

RETIRED AND RESERVE PERSONNEL

Retired personnel and Reserve personnel in inactive status are not entitled to access to classified information merely because of their present or former status. If a commanding officer believes granting certain retired or Reserve personnel access to specific classified information will promote the interests of national security, he or she may submit a request to the



DEPARTMENT OF THE NAVY
OFFICE OF THE NAVAL OPERATIONS
WASHINGTON, D.C. 20350

TOP SECRET

IN REPLY REFER TO
Ser 009DB/T123456
1 January 1995

TOP SECRET--RESTRICTED DATA--Critical Nuclear Weapon Design Information

From: Chief of Naval Operations
To: Recipients of this Marking Guide

Subj: TOP SECRET RESTRICTED DATA DOCUMENT THAT CONTAINS
CRITICAL NUCLEAR WEAPON DESIGN INFORMATION (U)

1. (TS) This is a sample classified document that contains Top Secret information that is Restricted Data as defined in the Atomic Energy Act of 1954. Some of that information is also "Critical Nuclear Weapon Design Information" as defined in SECNAVINST 5510.28, "Access to and Dissemination of Restricted Data", which implements DOD Directive 5210.2. The classification of this paragraph would be Top Secret as indicated by the precursory marking "(TS)."
2. (TS-RD) (N) This paragraph illustrates the marking of a paragraph that contains Top Secret Restricted Data that is also "Critical Nuclear Weapon Design Information." Restricted Data is abbreviated "RD" while the symbol "N" denotes "Critical Nuclear Weapon Design Information" in portion classification marking; it is otherwise abbreviated as "CNWDI."
3. (U) See SECNAVINST 5510.28 for related requirements.

SAMPLE

R. L. WELCH
By direction

Classified by CG-W-4
RESTRICTED DATA

This material contains Restricted Data as defined in the Atomic Energy Act of 1954. Unauthorized disclosure subject to administrative and criminal sanctions.

These markings may
be stamped or typed.

CRITICAL NUCLEAR
WEAPON DESIGN INFORMATION
DOD DIR 5210.2

TOP SECRET
TOP SECRET

Copy 3 of 5 copies
Page 1 of 1 pages

ISNP0019

NOTE: Top Secret for training, otherwise unclassified

Figure 4-5.—Top Secret Restricted Data markings.

CNO (N09N2) under the provisions of chapter 23 of the *Security Manual*.

As an exception to the above limitation, an active duty flag officer or general officer may waive the requirements for a valid investigation and grant a retired flag officer or general officer temporary access to classified information if there are compelling reasons in furtherance of a DON program or mission to grant such access. This access is limited to 90 days, and the flag officer or general officer granting the access must notify CNO (N09N2) of the event by a written report within 5 days.

Reserve personnel on active duty maybe granted access to classified information, as necessary, for either active or inactive duty training, provided they hold the appropriate clearance. The need for access must be determined by the granting authority or the authority with the information to be disclosed. A record of access granted must be maintained by the appropriate authority.

Refer to chapter 24 of the *Security Manual* for additional guidance on access and requirements for Reserve and retired personnel.

SECURITY VIOLATIONS AND COMPROMISES

When classified information has been lost, compromised, or subjected to compromise, action must be initiated to:

- Regain custody of the material, if feasible, and afford it proper protection.
- Evaluate the information compromised or subjected to compromise to determine the extent of potential damage to the national security, and take action necessary to minimize the effects of the damage.
- Discover the weakness in security procedures that caused or permitted the compromise or subsection to compromise, and revise procedures, as necessary, to prevent recurrence.
- Take appropriate disciplinary action, if individual responsibility is established.

ACTION REQUIRED

The commanding officer of a command that discovers a loss, compromise, or possible compromise must ensure that it is reported immediately to the nearest

Naval Criminal Investigative Service (NCIS) field office. The servicing NCIS will undertake investigative action. Timely referral is imperative to ensure preservation of evidence.

When a DON command receiving a report of a compromise or subsection to compromise does not have custodial responsibility for the material, the command must immediately notify the command having custodial responsibility and the NCIS field office. If the command having custodial responsibility cannot be determined, the command receiving the report must, to the extent feasible, conduct the required preliminary inquiry.

The command having custodial responsibility, upon receipt of a report of compromise or suspected compromise, must conduct a preliminary inquiry. Based on the findings of the preliminary inquiry, the command will determine whether to conduct an investigation and, if so, what type of investigation to convene. Refer to chapter II of the *Judge Advocate General Manual (JAGMAN)* for complete guidance on the type of investigation required. Concurrently, the NCIS may conduct its own investigation. Typically, the NCIS investigation will focus only on determining the presence of a counterintelligence interest or a prosecutable criminal violation. Commanding officers are required to conduct their own preliminary inquires and JAGMAN investigations, regardless of whether NCIS chooses to investigate as well. The three types of investigations (preliminary, JAGMAN, and NCIS) complement, but do not substitute for, one another.

RECORD OF INVESTIGATION

The required investigation is conducted as a JAGMAN investigation of the type determined to be appropriate by the convening authority. Interested parties are designated and accorded their rights as presented by chapter II of the *Manual of the Judge Advocate General*.

The investigation includes, but is not limited to:

- Identification of the cause, date, and circumstances of the compromise.
- Complete identification of each item of classified material involved.
- A list of the command(s) involved, by name and UIC, and individuals mentioned in the report. Required information includes mentioned individuals' full name, grade/rate or civilian status, billet title or duty assignment and, for

those against whom disciplinary action is recommended or taken, social security number, and date and place of birth.

- Findings of fact in the form of a chronology of the circumstances relating to the event.
- A finding of fact or opinion, as appropriate, establishing a time during which the material was subjected to compromise.
- A finding of fact or opinion, as appropriate, concerning the person or persons responsible, if individual culpability is indicated.
- A finding of fact or opinion concerning the probability of compromise.
- By reference, enclosure, or finding of fact, a statement that the originators of the material involved were notified.
- Recommendation of remedial action to be taken to prevent recurrence.
- Recommendation (when required by the appointing order) concerning disciplinary action.
- By reference, enclosure or finding of fact, a statement that the NCIS field office servicing the command was notified in a proper and timely manner and a narrative of the action NCIS took upon notification (that is, initiated investigation, declined investigation, and so forth).

DISPOSITION OF THE RECORD OF INVESTIGATION

Upon completion of the JAGMAN investigation, the convening authority must forward the original report to CNO (N09N2), by endorsement, through the chain of command or as directed by the cognizant commander. The endorsement must accomplish the following:

- Approve or disapprove the proceedings, findings of fact, opinions, and recommendations;
- State the measures taken, directed, or recommended to prevent recurrence;
- State the disciplinary action, if any, taken or recommended.

When punitive disciplinary action is contemplated against a person believed responsible for the compromise of classified information, classification

reviews must be coordinated with CNO (N09N2) and the legal counsel of the command where the individual responsible is assigned or employed.

CRYPTOGRAPHIC MATERIAL

To counter the threat posed to secure communications by Communication Security (COMSEC) material mishandling, losses, or thefts, the National Security Agency (NSA) established the National COMSEC Incident Reporting and Evaluation System (NCIRES).

The NCIRES serves primarily to ensure that all reported incidents involving COMSEC material are evaluated so that actions can be taken to minimize their adverse impact on national security. The NCIRES is composed of NSA, the heads of departments or agencies, material controlling authorities (CAs), and equipment resource managers. Within the DON, the incident reporting and evaluation system also includes Closing Action Authorities (CAAs).

Whenever loss, compromise, or subsection to compromise occurs in the case of cryptographic material or devices, action must be taken according to the *Communications Security Material System (CMS) Policy and Procedures Manual*, CMS 1.

CRYPTOGRAPHIC KEYING MATERIAL

To assist you in assessing compromise probability, CMS 1 provides guidance for handling the most commonly encountered or reported incidents, such as:

- Lost keying material, including material believed to have been destroyed without documentation, and material that is temporarily out of control (believed lost but later recovered);
- Unauthorized access; if an individual had the capability and opportunity to gain detailed knowledge of, or to alter information or material;
- Late destruction (not performed within required time) of COMSEC material; and
- Unauthorized absence of personnel who have access to keying material. Whenever this situation occurs, all materials he/she could have had accessed must be inventoried.

SECURITY VIOLATIONS

Violations of regulations pertaining to the safeguarding of classified material that do not result in

compromise or possible compromise are acted upon by the commanding officer of the individuals involved without reference to higher authority. The fact that a security violation has occurred may, at the discretion of the commanding officer, be considered sufficient justification for some form of formal disciplinary action.

If a container in which classified material is stored is found unlocked in the absence of personnel responsible for the container, a report must be made immediately to the senior duty officer or security manager (DO/SM). The container must be guarded until the DO/SM arrives at the location of the unlocked container. The DO/SM will inspect the classified material involved, lock the container, and make a security violation report to the commanding officer.

If the duty officer believes that classified information may have been compromised, he or she will require the person responsible for the container to return to the ship or station to make a complete inventory. Appropriate further action will then be taken by the commanding officer or higher authority.

Commanding officers who receive classified material that shows improper handling by the activity from which it was received must promptly notify the commanding officer of the sending activity. When circumstances indicate the information was not subjected to compromise, security violations involving improper mailing, shipment, wrapping, packaging or transmission, or failure to mark or address inner wrappings or envelopes should be reported to the command or activity from which the information was received. OPNAV Form 5511/51 (Security Discrepancy Notice) is used for this purpose.

If a command is notified that classified material has been subjected to compromise due to improper transmission, the sending command must initiate a Preliminary Inquiry Report detailing the loss, compromise or possible compromise. If the material was not compromised, the activity transmitting the material should investigate the violation and take corrective action to prevent its recurrence.

REPORT OF FINDING CLASSIFIED INFORMATION PREVIOUSLY REPORTED LOST

When classified material previously reported as lost is subsequently recovered and proven not to have been compromised, all addressees who were notified of the loss must be notified of the safe recovery.

SUBVERSION OF MILITARY PERSONNEL

There are a number of ways in which agents of foreign governments may attempt to subvert military personnel to gain access to security information. If you understand some of the methods used by foreign agents, you can be on the alert for actions that might get you involved with subversive parties.

You should understand that cost, time, and effort are no obstacles to a foreign government that really wants vital information. Trained agents may be sent to areas near military installations where they may spend weeks, months, or even years establishing themselves and becoming friendly with military personnel.

One of the favorite methods of subversion involves obtaining embarrassing or potentially harmful information about a person who might be in a position to obtain classified information. The information can pertain to almost anything, such as:

- Excessive alcohol abuse;
- Illicit personal relationships;
- Use of unauthorized drugs; or
- Excessive indebtedness.

These are but a few of the habits or actions that have gotten people into trouble. A person with a problem of this sort is fair game for foreign agents, since he or she can be blackmailed into doing things that violate security regulations.

Trained foreign agents know how to exploit weaknesses wherever they find them. For example, consider a petty officer who has gotten deeply into debt through gambling or just poor budgeting. The agent may skillfully get the petty officer even deeper in debt, then lend him money to help him get out of trouble. Eventually, the petty officer will find himself in a position where he feels that he can't refuse to give the agent small and relatively unimportant pieces of information. The information requested is usually minor at first, but the demands increase as time goes on. The petty officer may finally become so involved and so trapped that he ends up giving vital information to the agent.

A person who is married and has family obligations is a prime target for another approach. He or she may be taken to parties or other social gatherings and introduced to individuals who, unknown to him or her, are actually foreign agents or in the pay of foreign

agents. If such military personnel become sufficiency involved with one of these individuals, all meetings and actions are recorded and photographed without the victim's knowledge. When sufficient evidence has accumulated, the victim is blackmailed into turning over information. Again, small bits of relatively unimportant information may be requested at first, but soon more vital information will be demanded.

As you should see from these examples, a person who has been selected by a foreign agent to be a source of information is in a very difficult position. The person's weak points are emphasized and played upon until he or she feels completely trapped. In desperation, he or she feels that there is no other course of action than to operate and furnish information to the agent.

However, this is not true. There is always one honorable way to get out of this kind of difficulty. If you should ever find yourself entangled in such a situation, **DO NOT ALLOW YOURSELF TO BE BLACKMAILED**. Tell the whole story to your division officer, legal officer, or security officer. Don't try to handle the situation by yourself. Your chances of being able to outwit a highly-trained foreign agent are just about zero. Tell your story fully and completely, including any wrong actions of your own, and accept the consequences. Remember, whatever wrong actions you may have committed up to this point are nothing compared to the act of actually operating with a foreign agent.

SANITIZING CLASSIFIED MATERIAL

The sanitizing of classified material encompass two distinct processes. The first involves the downgrading or declassifying of the material. The second deals with protecting classified information within work spaces. We will first address the sanitizing of working spaces and then will go into more detail for downgrading or declassifying classified material for release.

SANITIZING WORKING SPACES

The principle behind sanitizing a working space is to protect any classified information or material from inadvertent disclosure. The basic actions involved are covering or putting away all classified materials and stopping discussions involving classified information. You should take these actions if, for example, an uncleared individual has to enter your space to repair, replace, or modify a particular system or item. The

individual should remain under escort and you must position all classified information to provide the maximum amount of protection from unauthorized disclosure. Particular situations may differ from command to command. In all cases, refer to your command SOP regarding the protection of classified information and take all steps necessary to prevent a possible compromise.

SANITIZING MATERIAL

Information classified by the DON must be declassified as soon as national security considerations permit. Decisions concerning declassifying or downgrading must be based on the loss of sensitivity of the information with the passage of time or the occurrence of an event that permits declassifying or downgrading.

Authority

The following officials are authorized to declassify and downgrade classified information:

- The Secretary of the Navy, with respect to all information over which the DON exercises final classification authority;
- The original classification authority, his or her successor, or a superior of either;
- The Deputies or Chiefs of Staff to the original classification authorities for the information within their functional areas;
- The Director of Naval History and Director of Marine Corps History and Museums, in coordination with other original classification authorities, for historical records in their custody.

The officials listed above are the only ones who may decide that specific information no longer requires the protection originally assigned; that is, only they can modify the original classification determination with a change in the classification guidance for that information. Do not confuse the authority to downgrade or declassify with the administrative responsibility of a holder of classified information to downgrade or declassify it as directed by a classification guide, the continued protection guidelines, or the instruction on a document.

Requirement

Navy and Marine Corps commands are no longer required to conduct a systematic review for declassification, but may want to review records in the interest of reducing classified holdings. There are, however, other options in which classified material is reviewed for declassification. They are:

- **Systematic declassification review**— The Archivist of the United States is responsible for systematic review for declassification of classified permanently valuable records in the National Archives as they become 30 years old.
- **Mandatory declassification review**— A U.S. citizen, immigrant alien, federal agency, state or local government may request a review for declassification of DON information. Information originated by a President, the White House staff, by committees, commissions, boards appointed by a President, or others specifically providing advice and counsel to a President is exempt from these provisions.
- **Requests for mandatory declassification review**— These requests are distinct from requests for records made under the Freedom of Information Act (FOIA). These requests for review of information and material originated by the Navy or Marine Corps must be submitted to the command originating the material or to the authority responsible for the subject. If neither of these is known, requests should be submitted to the CNO (Attn: N09B30).

DESTRUCTION OF CLASSIFIED ADP MATERIAL

Classified material on automatic data processing (ADP) media must be destroyed as soon it is no longer required. Chapter 17 of the *Security Manual* prescribes two procedures for destroying, or erasing, the material: *clearing* and *declassifying*. Normally, the medium on which the material is stored (floppy disks, hard drives, etc.) can be reused after the material has been destroyed. However, if the classified material cannot be destroyed completely, then the medium itself must be destroyed.

CLEARING AND DECLASSIFYING ADP MEDIA

Clearing and declassifying are similar, but they have different purposes and requirements. Both procedures are described below.

The clearing procedure is used when the media will remain within the processing facility and will be reused. The declassifying procedure maybe used for the same reason (in the case of magnetic tapes and disk packs) but it must be used when the media will be released outside the facility. For example, magnetic tapes or disks that will be released to another facility and equipment containing permanently installed ADP media (hard disk drives, and so forth) that will be sent out for repair or transferred to another facility must be treated with the declassifying procedure.

Cleared ADP media must still be marked, safeguarded, and controlled at the highest level of classification recorded on them before they were cleared. When a medium has been declassified, the classified information has, in effect, been destroyed. All markings identifying previous source, use, and classification must be removed. A record of declassification/destruction is required for media controlled as finished documents. Completing the record involves deleting the medium from the master list by lining through the item and entering the disposition, date of disposition, and the initials of the individual deleting the item. These records must be maintained for 2 years. Media considered to be working papers and those at the confidential level do not require a record of destruction.

The procedures for declassifying do not apply to media containing COMSEC keying material marked CRYPTOGRAPHIC. Those media are safeguarded as required for the highest classification ever recorded on them until they are physically destroyed. The procedures for clearing and declassifying magnetic media are as follows:

- **Magnetic tape**— Clear by overwriting one time with any one character. Declassify by degaussing with equipment approved by the National Security Agency. This equipment is available through the National Supply System.
- **Disks and disk packs**— Clear with one overwrite. Declassify by completely overwriting at least three times, once with the binary digit “1,” once with the binary digit “0,” and once with any other alphanumeric or special

character that will be left on the media. Verify the last overwrite, by attempting to read and print all characters other than the character used for the last overwrite.

- **Analog and video**— Use the same procedures described above, except use analog signals instead of digital signals.
- **Internal memory**— Clear by using a hardware clear switch, a power-on reset cycle, or a program designed to overwrite the storage area. Verify periodically to make sure the method is working correctly. Verification may be by random sampling or program read and compare. To declassify internal memory, refer to guidance specified in chapter 17 of the *Security Manual*.

INTRUSION DETECTION SYSTEMS

Intrusion Detection Systems (IDSs) provide a means of detecting and announcing proximity or intrusion that endangers or may endanger the security of a command. These systems are used for one or more of the following purposes:

- To permit more economic and efficient use of manpower by substituting mobile responding guard units for larger numbers of fixed guards or patrols;
- To take the place of other elements of physical security that cannot be used because of building layout, safety regulations, operating requirements, appearance, cost, and so forth; and
- To provide additional controls at vital areas as insurance against human or mechanical failure.

The use of IDSs in the protective program of a command may be required because of the critical importance of a facility or because of the location or the layout of the command. In some instances, their use may be justified as a more economical and efficient substitute for other protective measures,

When a command considers using IDSs as part of its protective program, its ultimate decision will be affected by the following conditions and situations:

- **Location and layout**— In certain cases, IDSs are necessary to take the place of the more usual protective elements, such as fences, lighting, and patrols.

- **Other considerations**— IDSs are justified only where their use results in a commensurate reduction or replacement of other protective elements without loss of protective effectiveness.

Intrusion detection systems are generally based on three types, or levels, of detection: *penetration*, *motion*, and *point*. Penetration detection is concerned with detecting unauthorized entry into a facility. Motion detection is concerned with detecting motion inside the facility. Point detection is concerned with detecting attempts to remove protected items from the facility. The degree of protection an IDS can provide depends on these factors:

- Internal and external threat;
- Location; and
- Primary points of attack, as described below.

Doors— Doors are a primary point of intrusion. An intruder can be expected to attempt entry by cutting, breaking, or otherwise defeating the lock or hinges, or by breaking through the door.

Alarm transmission lines— A knowledgeable intruder will probably first attack telephone or other transmission lines between the protected room and the monitoring area.

Walls, ceiling, floors— Windows in these structures, like doors, are a primary point of intrusion and are the hardest of all room features to protect.

Apertures— Any opening with its smallest dimension more than 6 inches and a cross-sectional area greater than 96 square inches, or any circular opening with a diameter greater than 10 inches, in walls, ceilings, floors, or doors must be considered a possible point of entry.

Personnel— Guards and personnel working within the secure area may be put under duress, allowing access to the secure area.

In-depth security can be achieved by equipping a secure area with at least two levels of detection, as shown in exhibit 14F of chapter 14 of the *Security Manual*. Remember, IDSs are designed to detect, not prevent, an attempted intrusion. Thus, a comprehensive physical security plan must contain enough physical security measures along with procedures for an effective reaction force.

ACTIVATION AND DEACTIVATION

Procedures to activate and deactivate any alarm system depend on the type of IDS you have. There are motion detection, point detection, and duress sensor type systems available. Always refer to your command's Standard Operating Procedures (SOPs) and the operating instructions of your particular IDS for complete guidance on the use of your alarm system.

TESTING

All alarm systems must be adjusted and maintained at the highest attainable sensitivity that will provide optimum performance and reliability without false or nuisance alarms. A record of the monthly test must be maintained and must reflect the date of each test, the names of persons completing the test, the results of the test, and any action taken in the event of malfunction. Refer to exhibit 14F of chapter 14 in the *Security Manual* for sample test procedures. Also, check with your security personnel periodically, as new types of systems are in development and the procedures for using and testing these systems may vary from those listed in chapter 14.

Additionally, periodic unannounced openings of a facility should be performed to test alarm responses by the monitoring guard force. These exercises determine the actual alarm response time and the ability of the guard to implement alerting procedures. The tests should be conducted in the spirit of assisting the guards in bettering their performance, thus increasing security. However, these tests should not be so frequent as to be considered a nuisance to the guard force. Testing must be coordinated with guard personnel who monitor the alarm system.

COMBINATIONS

A security container, vault, or strongroom must be fitted with a lock that resists opening by unauthorized persons. Manipulation-resistant and manipulation-proof locks are tested by the Underwriters Laboratory (UL) and must have the UL label attached to their back. As we stated in chapter 3, only persons whose official duties require access to a container for classified information may know its combination.

CHANGE PROCEDURES

Combination locks are available with two methods of combination change: hand change or key change. Changing the combination in a hand change lock requires removing the wheel pack from the lock and changing each wheel to the new combination. Changing the combination of a key change lock requires using a change key that is inserted into the lock case, permitting a new combination to be set. The type of combination lock desired is specified when the container is ordered.

The combination to a security container must be changed under any of the following circumstances:

- When the container is placed in use after procurement;
- Whenever an individual knowing the combination no longer requires access;
- The combination or record of combination has been compromised or the security container has been discovered unlocked and unattended;
- At least every two years, unless more frequent change is dictated by the type of material stored in the container.

When a container is taken out of service, the built-in combination lock must be in the locked position when the container is secured.

RECORD OF CHANGE

A record for each vault, secure room, or container used for storing classified material must be maintained, showing the location of the container, the names, home addresses, and home telephone numbers of persons knowing the combination. Standard Form 700, Security Container Information, must be used for this purpose (see figure 4-6). The security manager, duty officer, or other person designated by the command, must keep the records on file.

SUMMARY

Security is more than a matter of being careful; it requires both study and practice. A thorough understanding of this chapter will not provide full knowledge of all the finer points concerning security, but it will provide you a good fundamental background upon which security is built.

U.S. GOVERNMENT PRINTING OFFICE: 1986-06-068 ★	CLASSIFICATION																
	SECURITY CONTAINER INFORMATION																
	INSTRUCTIONS																
	1. COMPLETE PART 1 AND PART 2A (ON END OF FLAP).																
	2. DETACH PART 1 AND ATTACH TO INSIDE OF CONTAINER.																
	3. MARK PARTS 2 AND 2A WITH THE HIGHEST CLASSIFICATION STORED IN THIS CONTAINER.																
	4. DETACH PART 2A AND INSERT IN ENVELOPE.																
	5. SEE PRIVACY ACT STATEMENT ON REVERSE.																
	10. Immediately notify one of the following persons, if this container is found open and unattached.																
	<table border="1" style="width: 100%; border-collapse: collapse;"> <thead> <tr> <th style="width: 33%;">EMPLOYEE NAME</th> <th style="width: 33%;">HOME ADDRESS</th> <th style="width: 33%;">HOME PHONE</th> </tr> </thead> <tbody> <tr> <td>JOHN DOE</td> <td>8623 Georgia Ave., Silver Spring</td> <td>(301) 427-5969</td> </tr> <tr> <td>B. JOE SMITH</td> <td>1224 Oak Hill Rd., Olney</td> <td>(301) 555-1234</td> </tr> <tr> <td> </td> <td> </td> <td> </td> </tr> <tr> <td> </td> <td> </td> <td> </td> </tr> </tbody> </table>			EMPLOYEE NAME	HOME ADDRESS	HOME PHONE	JOHN DOE	8623 Georgia Ave., Silver Spring	(301) 427-5969	B. JOE SMITH	1224 Oak Hill Rd., Olney	(301) 555-1234					
EMPLOYEE NAME	HOME ADDRESS	HOME PHONE															
JOHN DOE	8623 Georgia Ave., Silver Spring	(301) 427-5969															
B. JOE SMITH	1224 Oak Hill Rd., Olney	(301) 555-1234															
<table border="1" style="width: 100%; border-collapse: collapse;"> <tr> <td style="width: 33%;">1. ATTACH TO INSIDE OF CONTAINER</td> <td style="width: 33%;">700-101 NSN 7540-01-214-5372</td> <td style="width: 33%;">STANDARD FORM 700 (8-85) Prescribed by GSA/ISOO 32 CFR 2003</td> </tr> </table>			1. ATTACH TO INSIDE OF CONTAINER	700-101 NSN 7540-01-214-5372	STANDARD FORM 700 (8-85) Prescribed by GSA/ISOO 32 CFR 2003												
1. ATTACH TO INSIDE OF CONTAINER	700-101 NSN 7540-01-214-5372	STANDARD FORM 700 (8-85) Prescribed by GSA/ISOO 32 CFR 2003															
CLASSIFICATION																	

WARNING
 WHEN COMBINATION ON PART 2A IS ENCLOSED, THIS ENVELOPE MUST BE SAFEGUARDED IN ACCORDANCE WITH APPROPRIATE SECURITY REQUIREMENTS.

DETACH HERE

CLASSIFICATION	
CONTAINER NUMBER	
13	
COMBINATION	
4	turns to the (right) (left) stop at <u>28</u>
3	turns to the (right) (left) stop at <u>77</u>
2	turns to the (right) (left) stop at <u>46</u>
1	turns to the (right) (left) stop at <u>0</u>
WARNING	
THIS COPY CONTAINS CLASSIFIED INFORMATION WHEN COMBINATION IS ENTERED	
UNCLASSIFIED UPON CHANGE OF COMBINATION	
2A	INSERT IN ENVELOPE
SF 700 (8-85) Prescribed by GSA/ISOO 32 CFR 2003	
CLASSIFICATION	
ISNP0020	

Figure 4-6.—Sample Standard Form 700.

CHAPTER 5

MAPPING, CHARTING, AND GEODESY

LEARNING OBJECTIVES

Upon completing this chapter you should be able to do the following:

- *Identify the six types of projections and how each is used to develop a map.*
 - *Explain how map scale is used in developing and reading maps and charts.*
 - *Explain the procedures used to plot geographic coordinates on maps and charts.*
 - *Explain the development and use of grid coordinates.*
 - *Identify and explain the use of marginal information on maps and charts.*
 - *Explain the development and use of Greenwich mean time (GMT).*
 - *Explain the methods used to indicate elevation and contours on maps and charts.*
 - *Identify and explain the use of the basic types of maps and charts.*
 - *Explain how to develop and use map overlays.*
 - *Describe the mission and functions of the map and chart development agencies.*
 - *Explain the basic procedures for procuring and stowing maps and charts.*
 - *Explain how to mount and annotate maps and charts.*
-

Maps and charts are frequently called “tools of the trade” in intelligent circles. There is certainly a great deal of truth to that statement. Maps and charts are to the IS what hand tools are to the aircraft mechanic. A MAP is a graphic illustration of selected features of the Earth’s surface drawn to scale; a CHART is a graphic illustration of one particular area especially designed for use in navigation. All intelligence functions are related directly to maps and charts. Without these graphic aids, Intelligent Specialists would be unable to answer questions, such as, “Where or how far is it?” Without maps and charts, a pilot couldn’t navigate an aircraft to the target, nor could a Navy skipper plot his ship’s course. Without maps and grid systems, a Navy gunner would be unable to aim his guns effectively.

Three-dimensional air warfare uses maps to a greater extent than does two-dimensional ground warfare. Because of the greater distances involved, the

wider distribution of forces, and because air attacks are made upon man-made objects (cities, steel mills, and the like), the maps we use *must be* accurate. In addition, we *must* know and understand them thoroughly.

To perform your **IS** duties effectively, you must have a thorough working knowledge of many different types of maps. This is not a difficult task. Once you have mastered the basic mechanics of map reading, your speed and accuracy will increase with practice.

MAP PROJECTIONS

Before describing how maps are made, we should first consider the characteristics desirable in a good map. These characteristics are:

- The scale should be constant over the whole map.

- The map should be conformal; that is, the map should show its angles equal to angles on the Earth, having the meridians and parallels intersect at right angles.
- The distance scale must be nearly constant in all directions from a given point to preserve the shapes of small areas on the Earth.
- Great circles should be shown as straight lines.
- A rhumb line, or line with constant direction, should be shown as a straight line. This is the line that an aircraft or ship tends to follow when it is navigated by a compass.
- Exact features join where adjacent maps sheet meet. There are many more desirable features, but these are the most important.

Taken together, these might be called the characteristics, or requirements, of a perfect map. However, a perfect map is impossible to construct. Therefore, all of these desirable characteristics can't be combined in one map. It is possible, however, to construct a map that fully satisfies a specific, especially important, requirement. Also, it is possible, by compromise, to construct a map that satisfies several of these requirements.

A spherical surface can't be spread out on a plane; it is said to be *nondevelopable*. We can't flatten a complete orange peel without tearing, stretching, or wrinkling it. Likewise, the surface of the Earth can't be perfectly represented on a flat surface.

However, we can flatten a small piece of orange peel with comparatively little tearing, stretching, or wrinkling because the piece is nearly flat to begin with. Likewise, a small, nearly flat area of the Earth can be represented on a map with little distortion. Distortion becomes a serious problem in mapping large areas in which the curvature of the Earth is evident.

Distortion can't be avoided entirely, but it can be controlled in drawing a map. Numerous systems, known as *projections*, have been devised to represent the Earth's surface on a plane. For any particular projection, a network of lines corresponding to geographic coordinates is established. This network of lines, known as a *graticule*, enables mapmakers to place each detail according to the projection used. The accuracy of measurements on a projection is based on a concept called *conformality*. A projection is said to be *conformal* if the distance measurements around the point or along the line on which the projection is based

are accurate. However, other measurements on the projection vary, according to their location. We will explain this in greater detail as we describe the various projections. To use a map effectively, we must understand the projection on which it was constructed, and the projection's purpose and good and bad features. The next paragraphs identify and describe the primary projections used in map and chart development.

MERCATOR PROJECTION

The Mercator projection (figure 5-1 [page 1 of 2]) is derived mathematically, but it may be described simply as a projection on a cylinder surrounding the globe and tangent to the globe at the Equator. After parallels (east-west lines) and meridians (north-south lines) have been projected onto the inside of the cylinder, the cylinder is cut vertically from bottom to top and laid flat.

The Mercator projection is a conformal projection. Distances along the parallels of latitude are accurate. However, the distance between the parallels becomes greater the farther they are from the Equator. This causes considerable distortion in the high latitudes, making the use of a constant scale for the entire chart impossible. For example, on a Mercator projection of the world, Greenland appears slightly larger than South America, although it is about one-ninth the size. To measure distances on a Mercator projection correctly, you must use as a linear scale the length of a minute of latitude measured midway between any two points in question.

Examples of charts constructed using the Mercator projection are the antisubmarine warfare plotting charts (ASWPCs).

LAMBERT CONFORMAL CONIC PROJECTION

The Lambert conformal projection (figure 5-1, page 1 of 2) is widely used in making aeronautical charts, as well as in constructing road maps and maps for classroom geographic studies. This projection is particularly adapted to air navigation since it affords maximum accuracy of distances and direction, thus increasing the speed and accuracy with which navigational problems can be solved.

Scale

The scale of a Lambert chart is practically constant. Therefore, any part of a graduated meridian maybe used

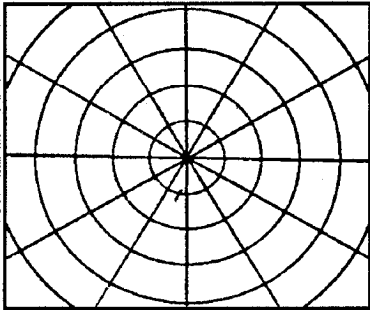
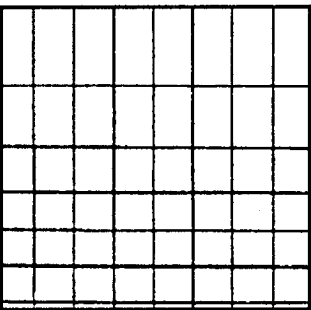
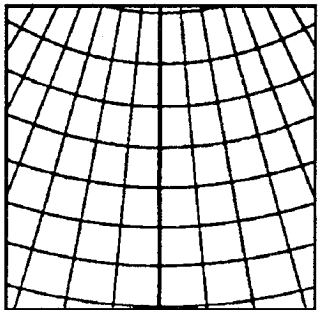
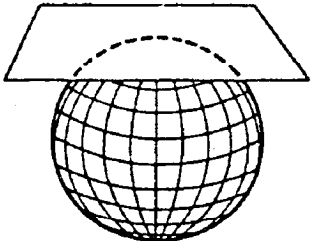
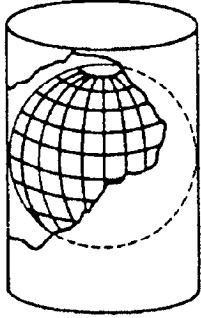
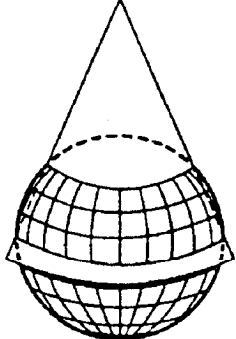
CHARACTERISTICS	POLAR STEREOGRAPHIC	MERCATOR	LAMBERT CONFORMAL
PARALLELS	CONCENTRIC CIRCLES UNEQUALLY SPACED	PARALLEL STRAIGHT LINES UNEQUALLY SPACED	ARCS OF CONCENTRIC CIRCLES NEARLY EQUALLY SPACED
MERIDIANS	STRAIGHT LINES RADIATING FROM THE POLE	PARALLEL STRAIGHT LINES EQUALLY SPACED	STRAIGHT LINES CONVERGING AT THE POLE
APPEARANCE OF PROJECTION			
ANGLE BETWEEN PARALLELS & MERIDIANS	90°	90°	90°
STRAIGHT LINE CROSSES MERIDIANS	VARIABLE ANGLE (APPROXIMATES GREAT CIRCLE)	CONSTANT ANGLE (RHUMB LINE)	VARIABLE ANGLE (APPROXIMATES GREAT CIRCLE)
GREAT CIRCLE	APPROXIMATED BY STRAIGHT LINE	CURVED LINE (EXCEPT EQUATOR AND MERIDIANS)	APPROXIMATED BY STRAIGHT LINE
RHUMB LINE	CURVED LINE	STRAIGHT LINE	CURVED LINE
DISTANCE SCALE	NEARLY CONSTANT EXCEPT ON SMALL SCALE CHARTS	MID-LATITUDE	NEARLY CONSTANT
GRAPHIC ILLUSTRATION	PLANE TANGENT AT POLE 	CYLINDER TANGENT AT EQUATOR 	SECANT CONE 
ORIGIN OF PROJECTORS	OPPOSITE POLE	CENTER OF SPHERE (FOR ILLUSTRATION ONLY)	CENTER OF SPHERE (FOR ILLUSTRATION ONLY)
DISTORTION OF SHAPES & AREAS	INCREASES AWAY FROM POLE	INCREASES AWAY FROM EQUATOR	VERY LITTLE
METHOD OF PRODUCTION	GRAPHIC OR MATHEMATICAL	MATHEMATICAL	MATHEMATICAL
NAVIGATIONAL USES	POLAR NAVIGATION, ALL TYPES	DEAD RECKONING AND CELESTIAL (SUITABLE FOR ALL TYPES)	PILOTAGE AND RADIO (SUITABLE FOR ALL TYPES)
CONFORMAL	YES	YES	YES

ISNP0021

Figure 5-1.—Projections (page 1 of 2).

as a graphic scale of nautical miles. In fact, distortion in scale on a Lambert chart is so small that a constant scale of measurement maybe used throughout the entire chart with negligible error. This makes possible the representation of large areas, such as the United States, by many small sections that maybe perfectly joined in any direction to form A large chart.

Development of a Lambert Projection

Like the Mercator projection, the Lambert projection is mathematically derived. Follow along on figure 5-1 as we describe the Lambert's development. As the name implies, the projection is developed on a cone. This cone intersects the surface of the Earth along two standard parallels. Since the Earth and the cone coincide at standard parallels, the Earth is projected inward upon the cone and is somewhat compressed. Thus, the scale of the cone is slightly smaller than the scale of the Earth. Beyond the limits of the standard parallels, the Earth's surface is projected outward on the cone and distortion increases rapidly if the chart extends for any great distance.

Advantages of a Lambert Projection

The primary advantage of the Lambert conformal projection lies in its accurate portrayal of physical features. A further advantage of this projection is that a straight line closely approximates the path of a great circle. A great circle is the circle formed on the Earth's surface when a plane is passed through the center of the Earth. The shortest distance from one point to another point on the Earth's surface is along a great circle. Therefore, for all practical purposes, a straight line on a Lambert conformal projection may be regarded as the shortest route between two points.

Disadvantage of a Lambert Projection

The main disadvantage of the Lambert projection to the pilot or navigator is that a rhumb line is not represented as a straight line. A rhumb line is a straight line that crosses two or more meridians at the same angle. The meridians on a Lambert projection converge toward the apex of the cone of development. This convergence on the chart requires the pilot or navigator to make frequent minor course changes in order to fly the desired path over the ground.

Some examples of charts constructed from the Lambert conformal conic projection are the USAF Pilotage Chart/Tactical Pilotage Chart, the Sectional

Chart, the Operational Navigation Chart (ONC), and the Jet Navigation Chart (JNC).

POLAR STEREOGRAPHIC PROJECTION

The polar stereographic projection is made on a plane that is tangent to the Earth at either pole, as shown in figure 5-1, page 1 of 2. The point of projection is the opposite pole. On the chart, the pole appears in the middle of the sheet. The meridians are depicted as straight lines radiating from the pole. The angle between any two meridians is equal to their differences of longitude. The latitude parallels appear as concentric circles about the pole, and their distances apart increase slightly with their distances from the pole.

A polar stereographic projection may include a whole hemisphere; however, the charts used by the military do not usually extend more than 30° from the pole. The characteristics given below apply only to this 30° type of chart.

Scale

Since the intervals between parallels on a polar stenographic projection increase with their distances from the pole, the north-south scale becomes slightly larger as the distance from the pole increases. The east-west scale also increases slightly, so that the scale, in any localized area, is constant for short distances in all directions. Within the limits of the chart, the scale changes little.

Angular Relationship

The meridians appear as radii of the circles that represent the parallels, so that the meridians and parallels intersect at 90° (right angles) on the chart, as they would on the Earth's surface. All other angles are shown correctly.

Great Circles

Great circles, other than meridians, appear slightly curved, but the closer they come to the pole, the more nearly straight they appear.

The polar stereographic projection is used primarily for polar navigation.

TRANSVERSE MERCATOR PROJECTION

The transverse Mercator projection (figure 5-1, page 2 of 2) is a conformal projection based on the

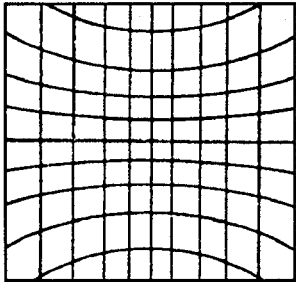
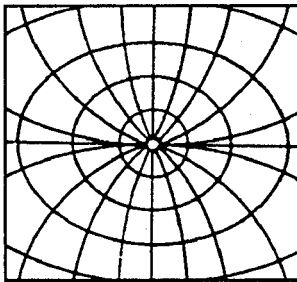
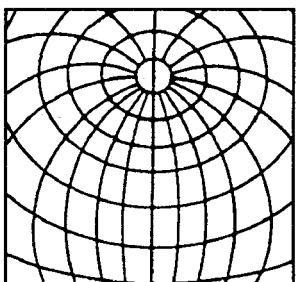
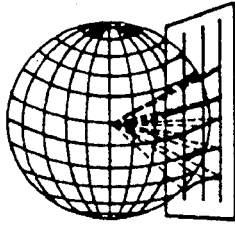
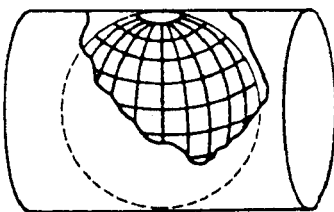
CHARACTERISTICS	GNOMONIC	TRANSVERSE MERCATOR	AZIMUTHAL EQUIDISTANT
PARALLELS	CONIC SECTIONS (CURVED LINES)	CURVES CONCAVE TOWARD NEAREST POLE	CURVED LINES
MERIDIANS	STRAIGHT LINES	COMPLEX CURVES CONCAVE TOWARD CENTRAL MERIDIAN	CURVED LINES
APPEARANCE OF PROJECTION			
ANGLE BETWEEN PARALLELS & MERIDIANS	VARIABLE ANGLE	90°	VARIABLE ANGLE
STRAIGHT LINE CROSSES MERIDIANS	VARIABLE ANGLE (GREAT CIRCLE)	VARIABLE ANGLE	VARIABLE ANGLE
GREAT CIRCLE	STRAIGHT LINE	CURVED LINE	STRAIGHT LINES RADIATING FROM CENTER
RHUMB LINE	CURVED LINE	CURVED LINE	CURVED LINE
DISTANCE SCALE			TRUE AT ALL AZIMUTHS FROM CENTER ONLY
GRAPHIC ILLUSTRATION			NO GEOMETRIC APPLICATION CAN BE SHOWN
ORIGIN OF PROJECTORS	CENTER OF SPHERE	CENTER OF SPHERE (FOR ILLUSTRATION ONLY)	
DISTORTION OF SHAPES & AREAS	INCREASES AWAY FROM CENTER OF PROJECTION	INCREASES AWAY FROM MERIDIAN OF TRUE SCALE	INCREASES AWAY FROM CENTER
METHOD OF PRODUCTION	GRAPHIC OR MATHEMATICAL	MATHEMATICAL	MATHEMATICAL
NAVIGATIONAL USES	GREAT CIRCLE NAVIGATION AND PLANNING	GRID NAVIGATION IN POLAR AREAS	AERONAUTICS, RADIO ENGINEERING & CELESTIAL MAPS
CONFORMAL	NO	YES	NO

ISNP0022

Figure 5-1.—Projections (page 2 of 2).

principle of projecting the Earth's graticule onto a cylinder tangent to the Earth along a particular meridian known as the *central meridian*, so that the tangent surface touches the Earth's poles. (Remember, the Mercator projection is tangent at the Equator.)

All other meridians will be curves bent toward the central meridian. The parallels will be curved lines bent toward the nearer pole. If we were to unwrap the cylinder and visualize a small portion Along the Equator, we would expect it to look like the illustration in figure 5-1, page 2 of 2. Since the transverse Mercator is a conformal projection, scale is constant and correctly represented along the referenced meridian, but elsewhere it is equally expanded and distorted. Distance measurements must be made in the same manner as on the Mercator projection.

You will frequently use charts constructed from the transverse Mercator projection, such as the Series 1501 Joint Operations Graphic—Air (JOG-AIR).

GNOMONIC PROJECTION

The gnomonic projection, like the polar stereographic, is made on a plane tangent to the Earth's surface. However, the plane of tangency of the gnomonic projection may be tangent to the Earth's surface at any point. (See figure 5-1, page 2 of 2.)

The gnomonic projection is based on two principles: (1) A great circle plane is a plane on which both the center of the Earth and a great circle are located. (2) The only planes in three dimension space that do not intersect a given plane are those planes that are parallel to it. Taken together, these two principles show that all great circle planes that are not parallel to the tangent plane **MUST** intersect it. Because the intersection of two planes forms a straight line, the intersection of the tangent plane and any great circle plane not parallel to it will be a straight line. This is the most important feature of the gnomonic projection.

The general appearance of the graticule depends upon the point of tangency. Since the Equator and the meridians are great circles, they always appear as straight lines. The parallels, other than the Equator, are not great circles; therefore, they always appear as curved lines. If either pole is the point of tangency, the meridians appear as straight lines radiating from the pole and the parallels as circles concentric about the pole.

If the point of tangency is on the Equator instead of the pole, the meridians appear as nonequidistant, parallel, straight lines. They are perpendicular to the Equator, which also appears as a straight line. The parallels appear as unequally spaced, nonparallel curves that are bowed toward the Equator at the center of the projection.

If the point of tangency is between the Equator and the pole, the meridians appear as converging straight lines. The central meridian intersects the Equator, and the parallels are at right angles.

The scale of a gnomonic projection expands rapidly as the distance increases from the point of tangency. It is constant in all directions *only* about the point of tangency. Most angles are misrepresented. Distances are, therefore, difficult to measure, and areas are not correctly displayed in shape. Plotting of points is difficult because of the irregularity of the graticule.

The gnomonic projection is principally used in planning great circle routes.

AZIMUTHAL EQUIDISTANT PROJECTION

The azimuthal equidistant projection (figure 5-1, page 2 of 2) is developed by plotting all points on the Earth at their true, great-circle direction and distance from a central point. The projection is not conformal, so that areas not in the vicinity of the central point are not shown in true size or shape. Distances and directions from one point to another are not true except when one of the points is the central point, or unless both points lie on a great circle that passes through the central point. For these reasons, this projection can't be used for navigation. This type of projection is used primarily for long distance planning.

MAP SCALE

Map scale is defined as a means of expressing the relationship between the size of the map (chart) and the size of the corresponding area that it represents on the Earth's surface. Scale may also be defined as the ratio between "map distance" and the corresponding "ground distance." There are several different ways of expressing scale, and different procedures are necessary in using each method. Three primary ways of indicating or expressing scale are:

- Representative fraction or ratio;
- Graphic scale; and
- Words and figures.

REPRESENTATIVE FRACTION (RF) OR RATIO

The most common method of expressing scale on military maps and charts is an RF or ratio, indicating that measurements on the charts represent a specified number of identical units of measure on the ground or the Earth's surface,

The RF is exactly what its name denotes, a fraction. This fraction compares a distance on the map (the numerator) with the corresponding distance on the ground (the denominator), both numbers referring to the same unit of measurement. The RF is always written with the map distance as "1." An RF of 1/50,000 or 1:50,000 means that one unit of measure on the map is equal to 50,000 of the same units of measure on the ground.

The RF or scale for military charts is conspicuously printed in the margin of the map sheet. It is usually indicated by an abbreviated statement, such as "Scale 1:500,000," where the colon indicates that it is a ratio rather than a fraction. Any convenient unit of measurement may be used with an RF or ratio to determine the relationship between map and ground distances. For example, if you measure 8 inches on a map that has an RF of 1/500,000, the mathematical formula for determining the ground distance is:

$$\text{Ground distance (GD)} = \frac{\text{map distance (md)}}{\text{representative fraction (RF)}}$$

$$\text{or } GD = \frac{md}{RF}$$

Substituting:

$$GD = \frac{8''}{1/500,000}$$

Solving: $GD = \frac{8'' \times 500,000}{1}$

(Reminder: To divide by a fraction, invert the fraction and multiply.)

Then: $GD = \frac{4,000,000}{1}$

or $GD = 4,000,000$ inches

As you can see in the example above, using a representative fraction in a formula is cumbersome. An easier method for determining distances is to use the reciprocal (inverted fraction) of the RF, which we call the Map Scale Reciprocal (MSR). The reciprocal of a fraction is merely that fraction inverted. In other words, the denominator becomes the numerator, and the numerator becomes the denominator. For example, the reciprocal of the RF 1/500,000 is 500,000/1, so the MSR is 500,000. This provides a term for scale which is a whole number that can be used to determine ground distances. Ground distance is equal to the distance measured on the map multiplied by the MSR. Using MSR, rather than RF, the mathematical formula now becomes:

$$GD = md \times MSR$$

Where:

GD = ground distance;

md = map distance; and

MSR = map scale reciprocal.

Example:

Find the ground distance represented on the map when

$$\text{map RF} = 1/250,000$$

$$md = 0.270 \text{ feet}$$

Solution:

$$D = md \times MSR = 0.270 \text{ feet} \times 250,000 = 67,500 \text{ feet}$$

Therefore, the ground distance that is represented on the map is 67,500 feet.

Remember that the larger the MSR becomes, the smaller the RF becomes. Since the RF is the actual scale, the map is said to be of larger or smaller scale, depending upon whether the RF becomes larger or smaller. An easy way to understand the difference between large-scale and small-scale maps is to remember that large-scale maps show small areas, and small-scale maps show large areas.

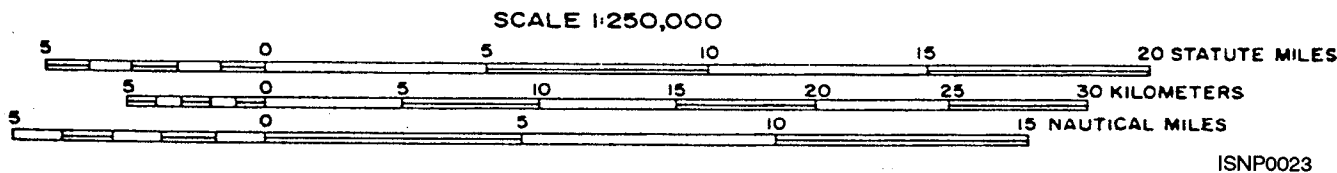

Figure 5-2.—Graphic scale.

GRAPHIC SCALE

The bar, or graphic, scale that is found in the marginal information on a map is for measuring distances. (See figure 5-2.) This method of scale expression is simply a kind of ruler printed on the map. This scale is used to determine visually the number of linear units between points on the map. The standard practice is to show these graphic or bar scales graduated in statute miles, nautical miles, kilometers, or yards.

Graphic scales are normally constructed so there is one division to the left of “zero” that is subdivided into smaller increments. This subdivided portion is called the *extension* and is used to obtain precise measurement of distance.

A simple graphic scale, as shown in figure 5-2, is sufficient for measuring distances on maps, such as some Lambert conformals, which cover a relatively small area. However, for other types of maps, such as Mercators and polar stereographic on which the scale varies considerably with the latitude of the route to be measured, it is necessary to use a *nomographic* or *latitude scale*, as shown in figure 5-3.

The latitude scale is a graphic scale that provides a series of bar scales, each accurate for a different latitude. Fairly accurate measurements can be made by using the bar scale that corresponds to the mean latitude of the area or route being measured. For measurements made at intermediate latitudes not printed on the scale, interpolation may be used.

To illustrate, let’s assume that the mean latitude between “A” and “B” on a map is 30°. The distance between the points is measured on the map and laid off on the 30° latitude line on the scale, as shown in figure 5-3. The distance measures 330 miles. Similarly, consider that the mean latitude between points “C” and “D” on a map is 55°. The distance between the points is measured and laid off midway between the 50° and 60° latitude lines. This distance measures 420 miles.

Another graphic method of measuring distance on a chart involves using the latitude lines of the geographic coordinate graticule. Many medium- and large-scale charts show latitude in minute “tick” marks. Each minute equals 1 nautical mile. Each minute tick mark is located along one or more of the meridians shown on the chart and may conveniently be used as a scale.

When minutes of latitude are used for measuring distance, it is very important to use the scale at the same latitude as the route or distance being measured. On charts, such as the Mercator and polar stereographic, on which different latitudes are represented in different scales, substantial error will result when this procedure is not followed.

The use of a graphic or latitude scale instead of a separate instrument to measure distance, such as a Weems plotter, avoids much of the error introduced by map paper shrinkage. These scales, drawn on the map sheet itself, are subject to shrinkage along with the map. Although map paper does not shrink to the same extent in all directions, the amount of error normally resulting

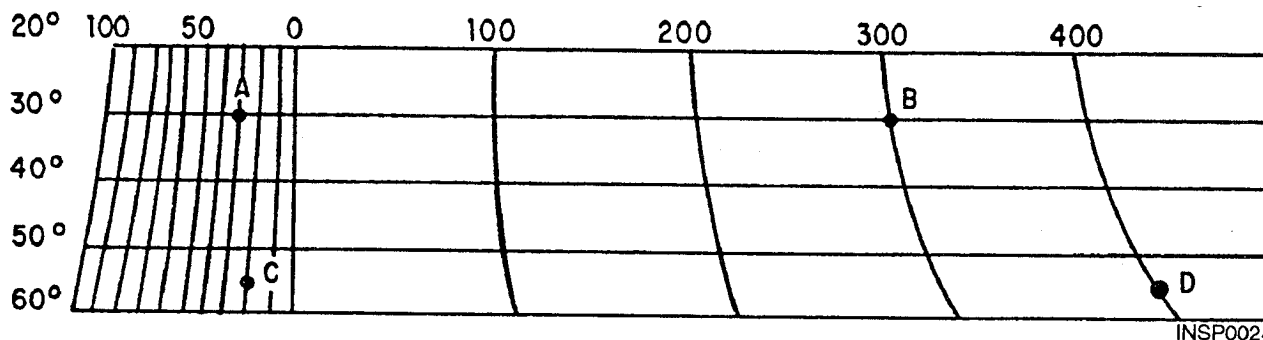

Figure 5-3.—Nomographic or latitude graphic scale.

from shrinkage is materially reduced by the use of these scales.

WORDS AND FIGURES

A third method of expressing scale is by “words and figures.” Two examples of a scale expressed in words and figures are 1 inch= 1,000 feet and 1 inch= 1 mile.

This system of expressing scale is intended to give the reader an approximation of the ground distance in terms of familiar linear units. Note that in using the words and figures method, expressions of map and ground distance are given in different units, where 1 unit equals 1,000 feet or 1 mile.

Use care whenever you convert these expressions to the corresponding MSR, in which both md and GD are expressed in the same units. For the examples of 1 inch equals 1,000 feet and 1 inch equals 1 mile, the MSRs are 12,000 inches and 63,360 inches, respectively, since there are 12,000 inches in 1,000 feet and 63,360 inches in 1 mile.

Table of Commonly Used Map Scales and Equivalentents

You will find the following tables of equivalentents useful in working problems involving map scales and distances. Memorize the quantities marked with an asterisk (*).

Fractional Scale or Ratio	Miles Per Inch	
	Nautical	Statute
1:50,000	0.685	0.789
1:63,360	0.868	1.000
1:100,000	1.370	1.578
1:250,000	3.426	3.946
1:500,000	6.853	7.891
1:1,000,000	13.705	15.783
1:2,000,000	27.411	31.565

- * 5,280 feet = 1 statute mile
- * 6,080 feet = 1 nautical mile (approximate)
- * 3,280 feet = 1 kilometer
- * 1,000 meters = 1 kilometer
- * 1 meter = 39.37 inches (approximate)

The United States standard value for the nautical mile is 6,080.2 feet. However, for the purpose of this training manual and for most “field” work, 6,080 feet is sufficiently accurate.

To convert:

Statute miles to nautical miles, multiply statute miles by 0.87;

Nautical miles to statute miles, multiply nautical miles by 1.15;

Statute miles to kilometers, multiply statute miles by 1.61;

Nautical miles to kilometers, multiply nautical miles by 1.85;

Kilometers to statute miles, multiply kilometers by 0.62; and

Kilometers to nautical miles, multiply kilometers by 0.54.

GEOGRAPHIC COORDINATES

To locate points relative to one another, it is necessary to use the concepts of direction and distance. These can be specified only by using a system of terms. Primitive man probably did this in relative terms, using such aids as the directions of the rising and setting sun, forward and backward, and left and right. He probably expressed distance in terms of travel time, all of these being reckoned in relation to his own location. Any universal or general system, however, must be established in relation to some unique reference or starting point. If such a point is designated, then the location of every other point can be stated in terms of a defined direction and distance from it.

The most widely accepted system of locating a specific point on the Earth’s surface uses lines of latitude and longitude, collectively known as *geographic coordinates*. Because these coordinate lines are used for measurement of a spherical surface, such as the Earth, they are divided, like a circle, into:

- Degrees (°);
- Minutes (′); and
- Seconds (″).

Coordinates allow us to provide an answer to the crucial intelligence question, “Where is it?”

LATITUDE

When you draw a grid on a globe, you must have a point at which to start. Unlike drawing a grid on a piece of paper, where you can start in a corner or at the center, on a globe you must have a point of origin that is agreed on by everybody. The point of origin for latitude is the Equator. The Equator is an imaginary line running east and west around the center of the Earth with a numerical value of 0° . The Equator is a great circle that divides the sphere horizontally into equal parts. These parts are known as the Northern and Southern hemispheres.

Latitude locates a place relative to the Equator. The numbering of lines of latitude begins with 0° at the Equator and increases towards the poles on both sides of the Equator. Therefore, it is always necessary to show whether the latitude of a place is north or south of the Equator. (See figure 5-4.)

The degree value of a line of latitude is determined by the angle formed by drawing a line from the Equator to the center of the Earth and then back out to that line

of latitude on the surface of the Earth. Since the value of any given angle is constant all the way around the Earth, a line drawn on the Earth's surface connecting all the points that are formed by the angle is parallel to the Equator. For this reason, latitude is commonly referred to as a "parallel of latitude" or simply "parallel." Since 90° is straight up or down in relation to the Equator, the North and South poles are located 90° from the Equator. The lines of latitude, then, will have degree values greater than 0° but less than 90° , both north and south of the Equator.

Each degree is subdivided into 60 *minutes*. For instance, between 48° and 49° north latitude there are 60 minutes. A point located halfway between 48° and 49° north latitude, as shown in figure 5-5, is located at 48 degrees, 30 minutes north ($48^{\circ}30'N.$) Each minute is subdivided into 60 *seconds*. For the example above, a point located one-quarter of the way between 30' and 31' is located at 48 degrees, 30 minutes, 15 seconds north ($48^{\circ}30'15"N.$) (See figure 5-5.)

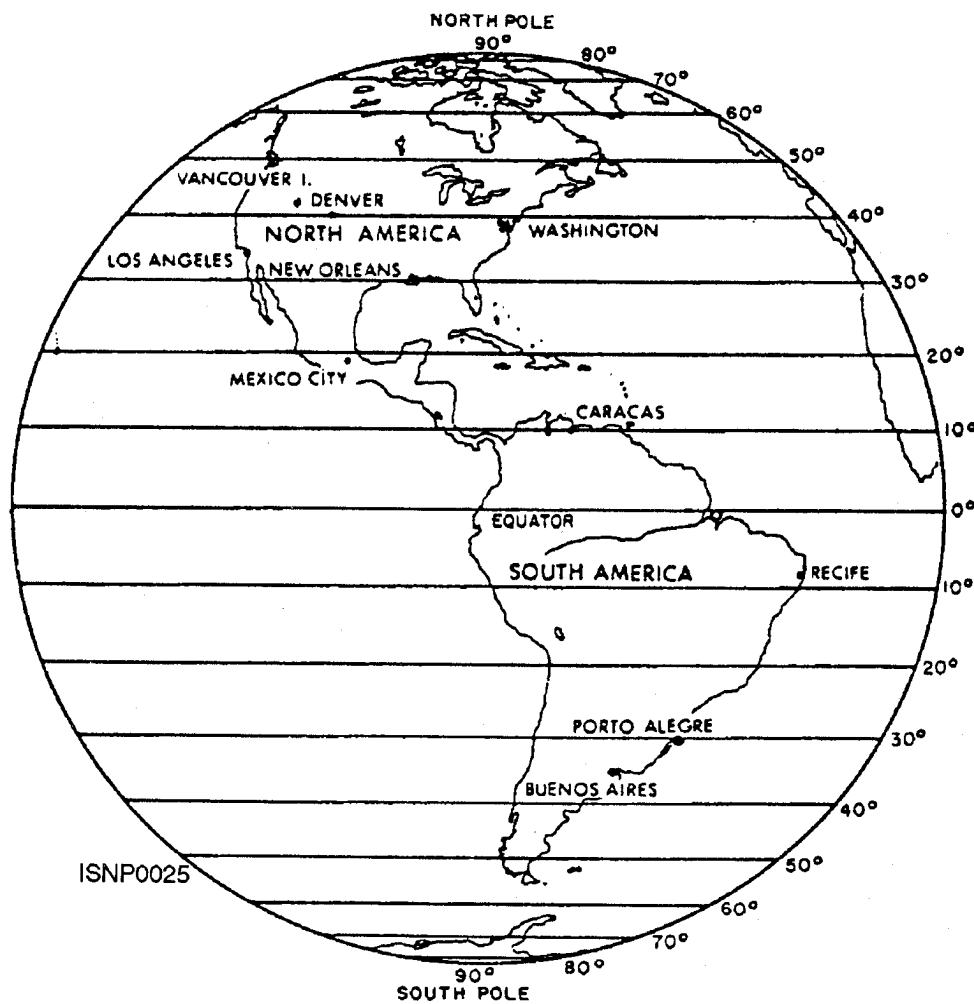
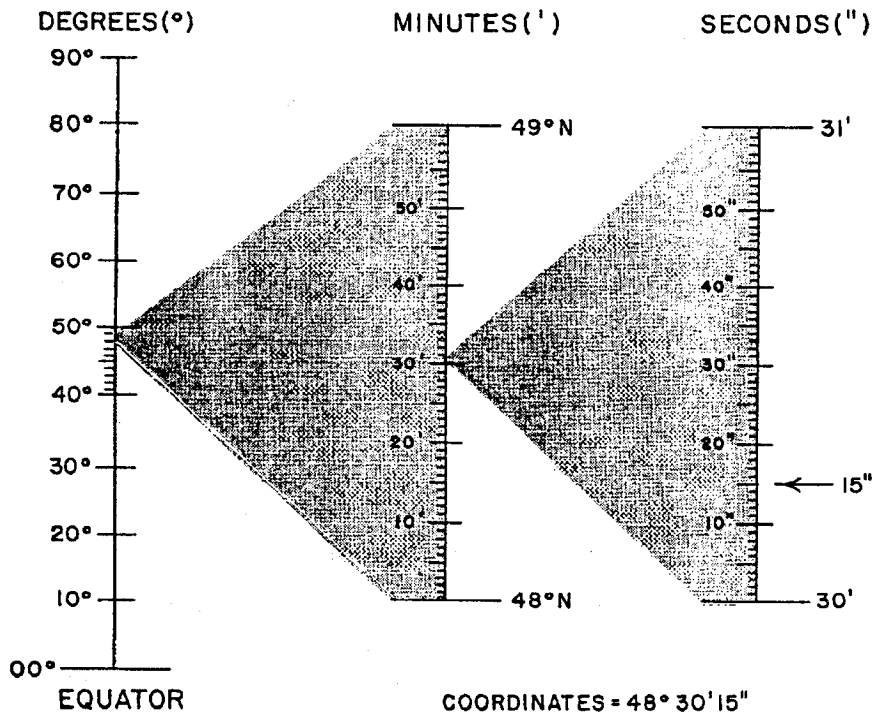

Figure 5-4.—Parallels of latitude,



ISNP0026

Figure 5-5.—Degrees, minutes, and seconds.

The military writes coordinates using a system called *military notation* without the °, ', and " signs. This system uses six numbers plus the letter indicating north or south. Thus, the coordinate shown above is written as 483015N. When a position is located so that there are less than 10 degrees latitude in its coordinate designation, a zero is added to the left of the degree number so that there are still two digits. Seven degrees of latitude then appears as "07" in the designation. Likewise, two digits are used to designate minutes and two digits for seconds; for example, 030704N or 801708S.

LONGITUDE

At this point you have half of the grid, or all the horizontal lines. The point of origin for the vertical lines, or longitude, on American and British maps is an imaginary line running from the North Pole to the South Pole, directly through Greenwich, England. Like the Equator, it has a numerical value of 0°. For purposes of identification, it is called the Greenwich meridian or the prime meridian. Many foreign maps do not use this Greenwich meridian as the prime meridian. For example, French maps use the Paris meridian, and Italian maps use the Rome meridian. Whenever you use foreign maps, examine the marginal data to determine the prime meridian that is used. (See figure 5-6.)

The prime meridian combined with the 180th meridian divides the Earth into two equal vertical parts, the Eastern Hemisphere to the right of the prime meridian and the Western Hemisphere to the left of the prime meridian. All the other lines of longitude are simply called meridians.

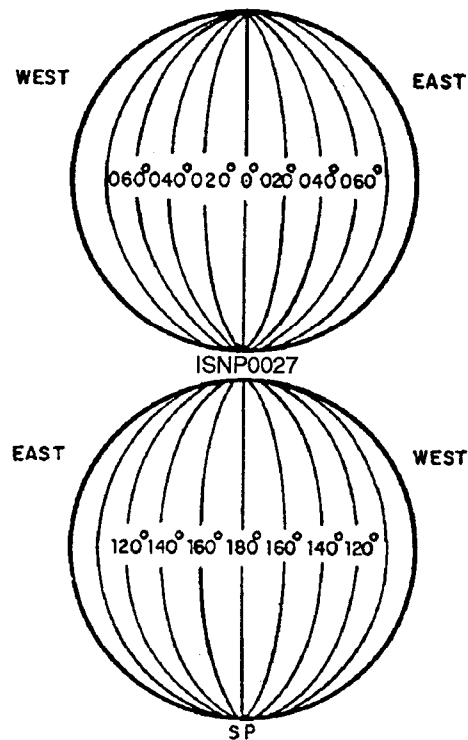

Figure 5-6.—Meridians of longitude.

Longitude locates a place relative to the prime meridian. (See figure 5-7.) The numbering of meridians begins with 0° at the prime meridian and increases to both the east and west. Therefore, it is always necessary to show whether the longitude of a place is east or west of the prime meridian.

The value of a meridian is determined by the angle formed by drawing a line from the Equator, at the point where the prime meridian crosses it, to the center of the Earth, and then back out to another point on the Equator. The angle formed by the intersection of those two lines is then measured, and that value is assigned to that meridian. In this way, the angles are measured all around the Earth in both an east and west direction toward 180°. Since each half of the globe contains 180° of longitude, the entire globe contains 360°, the number of degrees in a circle.

Each degree of longitude is subdivided into minutes and seconds in the same manner as each degree of latitude. However, you should remember two things about longitude:

- West longitude is measured from right to left on a map; east longitude is measured from left to right.
- When the degrees portion of the coordinate is written in military notation, it is written as three digits; for example, 0074321 W for 7 degrees, 43 minutes, 21 seconds west.

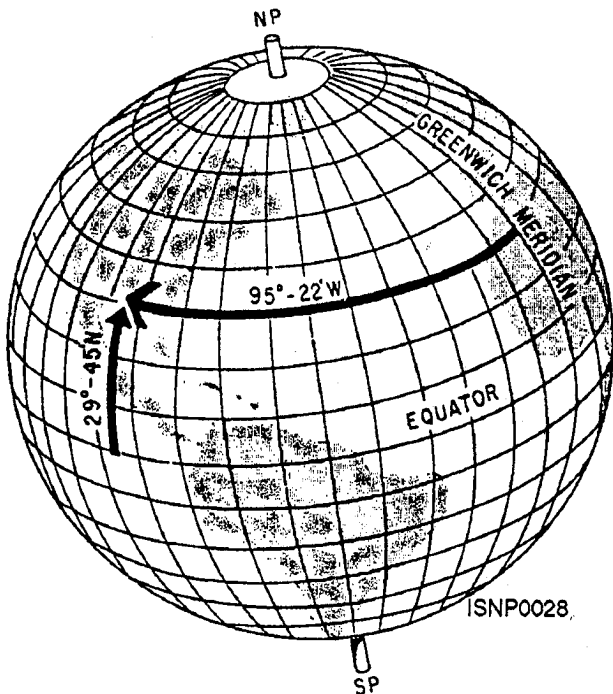

Figure 5-7.—Latitude and longitude measurements.

DIRECTION

In addition to being able to tell from a map how far away an object is and what its specific location is, you must be able to determine “Which way is it?” or, in other words, “In what direction does it lie?”

For our purposes, the term “direction” means the bearing or course upon which you move from one point to another. When you can see your destination from where you stand or are familiar with the route you must travel to reach your destination, you need no special way of designating the direction of travel. However, if you must travel long distances in or over open water, through the air in darkness, or if you just wish to describe a direction of travel, you must be able to indicate direction in commonly known terms.

One widely used “direction of common knowledge” is the direction of the North Pole from a position. Other directions used by military forces are the directions of a position from the “magnetic pole,” certain celestial bodies, and the grid reference lines on maps.

The following systems are widely used to indicate a direction of travel in reference to a direction of common knowledge.

The Cardinal Point System

For centuries, a system of compass readings called *compass points* has been used to indicate direction. An observer at any geographical location can use the cardinal points of the compass (north, east, south, and west) and the intervening points between each cardinal point to indicate the direction from that location to another location.

There are a total of 32 equally spaced, named points. Figure 5-8 shows the 32 points. The direction

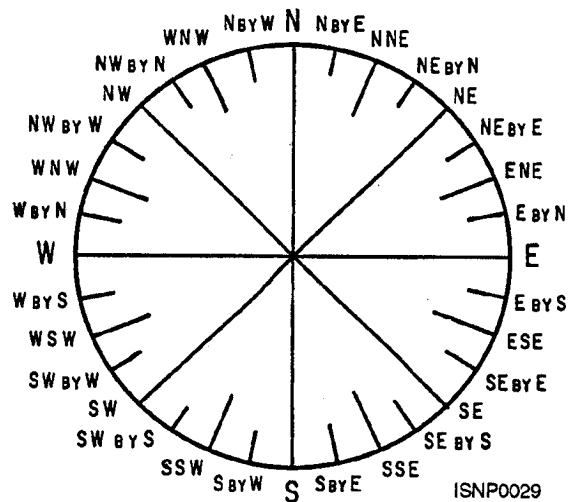

Figure 5-8.—The cardinal point system used on the mariner's compass.

called *east* is toward the rising sun and west is toward the setting sun. The cardinal point system maybe used when a high degree of accuracy in the direction of travel is not required.

The Azimuth System

The azimuth system has been used for many years to get precise measurements of direction. It has been used on naval compasses and is presently used by the U.S. Air Force. The azimuth system measures direction by dividing a circle into 360 equal parts, called *degrees*, and subdividing each degree into minutes and seconds (60 minutes in each degree and 60 seconds in each minute). When this system is used, a direction is measured in degrees, minutes, and seconds clockwise from north in a horizontal plane.

Some marine compasses show both the cardinal point and azimuth figures on their cards, but it is unusual to see more than the principal four or eight cardinal points represented. For general navigational purposes, subdivisions of a degree are not necessary.

The Mil System

In the mil system, the circle is divided into 6,400 equal parts called *mils*. This permits measurement of

angles of less than 10 without using the cumbersome minute and second subdivisions.

The mil system is widely used by ground forces for such purposes as directing artillery fire that requires accuracy greater than a full degree. Some protractors and compasses are graduated in mils, and some field glasses used by the ground forces are provided with a mil scale. In the mil system, an object measuring 1 mil of angle has a length of 1 foot (approximately) for every 1,000 feet of distance between the object and the observer.

You can convert degrees into mils and mils into degrees by using the following conversion factors:

$$1 \text{ degree} = 17.8 \text{ mils};$$

$$1 \text{ mil} = 0.05625 \text{ degrees, or } 3 \text{ minutes } 22\text{-}1/2 \text{ seconds.}$$

Measuring Direction

Measuring direction on a map requires the use of some type of instrument. The Weems plotter (figure 5-9) is an excellent tool for this purpose. The Weems plotter is merely a protractor with a scale on the outer

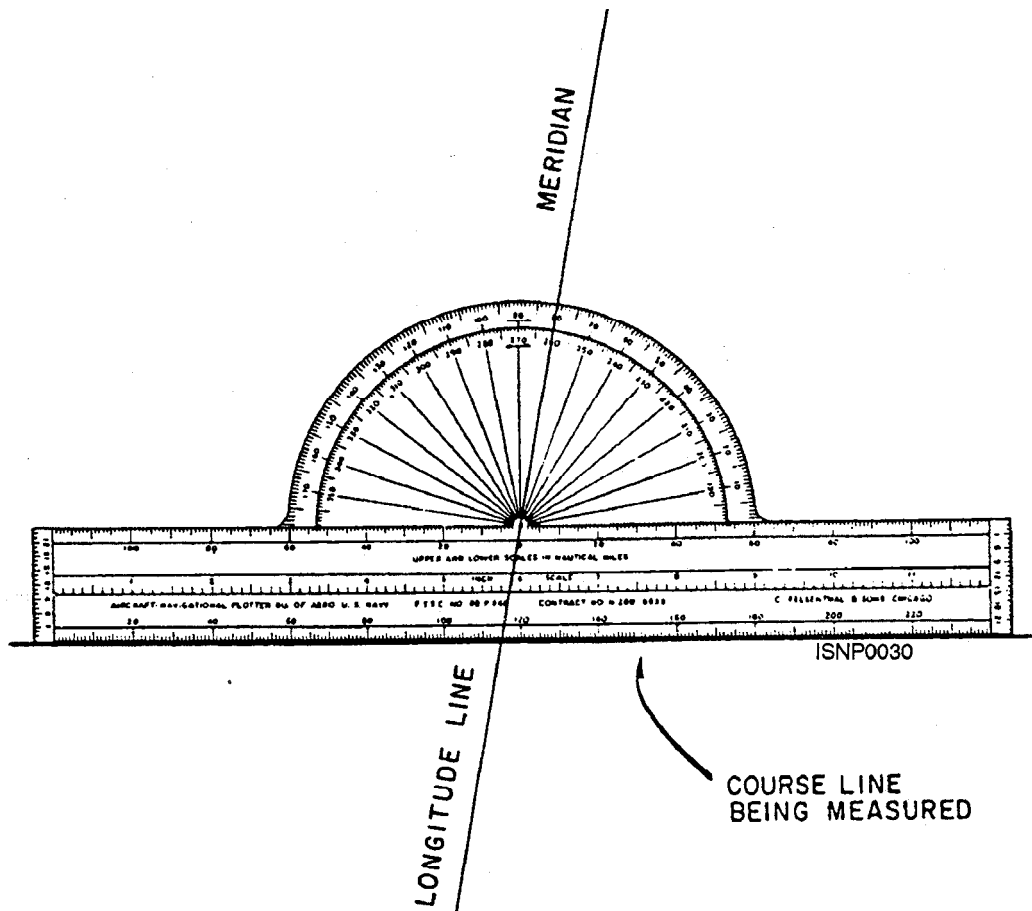

Figure 5-9.—Determining course direction with Weems plotter.

rim of the curved segment to use for measuring angles or, in this case, angular (course) direction.

A complete turn in azimuth describes 360°, but the Weems plotter shows only half a circle. On close examination, however, you will see that there are two scales on the outer protractor edge, one from 0° to 180° and one from 180° to 360°.

By using these two scales, you can measure any angular direction from 0° to 360°.

1. To measure a course direction, first draw a line on the map connecting the beginning and ending points of the course.
2. Next, select a meridian on the map to use as the base (or standard) from which to measure the course angle. The meridian you select should intersect the marked course line. If the course line lies entirely between two meridians, either draw in a supplementary meridian so that it intersects the course line or project the course line so that it crosses a meridian.
3. Place the plotter right side up on the map and locate the center hole at the base of the protractor scale over the intersection of the meridian and the course line.

NOTE: The proper use of the plotter requires that the curved segment of the plotter always be placed toward the TOP of the map.

4. Align the straight edge of the plotter along the course line, then, with the center hole over the meridian/course line intersection, read the course from the protractor scale where the meridian intersects the correct scale. Be sure to use the proper scale. Notice that each scale has a small arrow on the 90°/270° line. Use the scale whose arrow points in the same direction as travel along the course line. For example, to determine specific course directions for travel in easterly directions, use the top scale. The course direction is indicated by the point at which the meridian crosses the protractor scale.

The direction measurements described above use the meridians as a base or standard. Since these meridians always point to true north, all directions measured are true directions.

There are two other base directions found on many maps, particularly those produced by the Defense Mapping Agency Hydrographic/Topographic Center. These are *magnetic north* and *grid north*.

Magnetic north is determined by the magnetic compass and, therefore, is commonly used in military field operations and navigation, both surface and air.

Grid north is the direction represented by the north-south grid lines on a map. This type of base direction is used primarily in ground operations, such as artillery spotting and close air support.

Except for true north, base directions are not constant for all sections of the Earth's surface, nor are they constant on the maps representing portions of that surface. Therefore, you must understand the causes of these variations and the methods of distinguishing them.

Variations in the Earth's magnetic field cause the needle of a magnetic compass to be pulled away from true north. Differences in the amount of pull are the direct result of variances in the magnetic attraction in different localities. Furthermore, the attraction in one locality is not constant over a period of time; there is a gradual change.

Grid direction also varies in different localities. Since this property is constructed into a grid when it is superimposed on a map, this variance has no connection with map reading from the standpoint of grid coordinates.

Since you will do considerable work with grid references, you must know the relationship of magnetic north and true north to grid north in the area of interest. These values are printed on the face of maps, usually in the marginal information.

On large-scale maps, the information is expressed as a declination diagram. (See figure 5-10.) The declination diagram, through the grid-magnetic angle (G-M angle), indicates the directional difference between grid north and magnetic north. It also indicates the year the declination was computed. The value of the G-M angle is expressed in degrees and minutes, with mil equivalents shown to the nearest 10 mils. (10 is equal to approximately 18 mils.) Conversion notes appear with the declination diagram to explain the use of the grid-magnetic angle (G-M angle). One conversion note provides instructions for converting magnetic azimuth to grid azimuth, and the other note provides instructions for converting grid azimuth to magnetic azimuth. The conversion (adding or subtracting the G-M angle value) is governed by the direction of magnetic north relative to that of grid north. (See figure 5-10.)

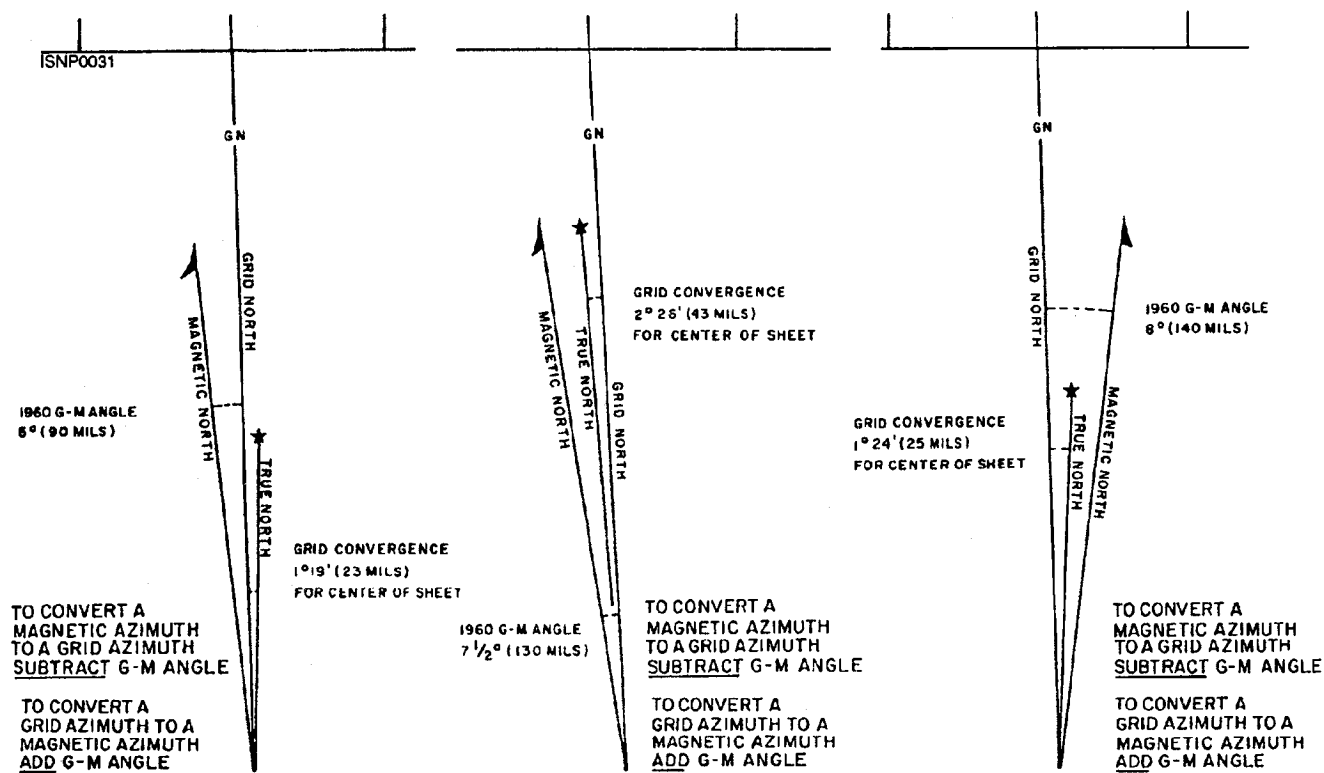

Figure 5-10.—Declination diagrams.

If a map sheet does not have a declination diagram, conversion notes about the G-M angle value and instructions explaining how to convert from one azimuth to another will be included in the marginal information.

In measuring distances on a map, you will normally use the nautical mile, which is equal to approximately 6,080.2 feet. For practical purposes, the value of 6,080 feet is normally used. This length is used because it is almost the equivalent of 1 minute of arc of a great circle on the Earth. Let's see what this means.

The distance around the Earth at the Equator (a great circle) is 21,600 nautical miles. Since the Equator is a great circle and there are 360° in a circle, each degree of arc at the Equator is equal to 60 nautical miles ($21,600 \div 360 = 60$). Further, since the Earth is generally considered to be a sphere, the meridians and the Equator can be considered as great circles of the same size. Since a nautical mile is about equal to 1 minute of arc of a great circle, 1 nautical mile equals 1 minute of arc on a meridian or 1 minute of latitude.

A nautical mile also equals 1 minute of arc (1 minute of longitude) on the Equator. Since the Equator is the only parallel that is a great circle, a nautical mile

does not equal a minute of longitude anywhere on the Earth's surface other than at the Equator. Remember this, because this is used whenever distance is measured.

Methods for measuring distances on maps vary according to the projection used to construct the map. Since a map constructed from the Mercator projection presents some unique problems with measurements, we will discuss the process of taking measurements from this type of map. Measurements are made on a map constructed from the transverse Mercator projection in the same way as they are on a map constructed from a Mercator projection. This is an important point to remember, as you will frequently use maps constructed from the transverse Mercator projection.

One of the greatest problems in using a Mercator chart is the lack of a constant scale. Since no one scale can be used at all latitudes, the chart cannot be provided with a single graphic scale.

However, a graduated meridian shows the correct scale at each latitude. To measure distance, use a section of the graduated meridian that has the same average scale as the average scale over the distance measured. This is a section of the meridian, as shown

in figure 5-11, where the mid-latitude is the same as the mid-latitude of the two points between which you measure the distance. This scale, called the mid-latitude scale, is not exactly equal to the average scale, but it is close enough for practical purposes.

If you can span the total distance with your dividers, then you can measure the distance on the graduated meridian by placing the dividers on the meridian at equal distances from the mid-latitude. For a longer distance, set the dividers at some convenient distance on the mid-latitude scale, such as 60' (60 nautical miles). Remember, you do this by placing the points at equal distance from the mid-latitude. Step off the distance on the course line, counting the steps. After the last full step, reset the dividers at the remaining shorter distance and read this distance from the graduated meridian at the mid-latitude. Add the shorter distance to the distance represented by all the full steps to determine the course distance.

The mid-latitude scale is accurate enough if the course does not cover more than about 5° of latitude. If the course does cover more than 5° of latitude, divide it into *legs* and measure the length of each leg with the mid-latitude scale of that leg.

GRID COORDINATES

Throughout history, military leaders realized the necessity for a reference system, other than the geographic grid system, that defines the location of points with easy-to-read coordinates. Various systems were devised, but most of them proved unsatisfactory.

In 1949, the Joint Intelligence Committee of the Joint Chiefs of Staff prescribed the use of the Universal

Transverse Mercator (UTM) grid system by all branches of the Armed Forces for use in joint operations in limited areas when ground forces are involved. The Navy and Air Force usually use the World Geographic Reference System (GEOREF) in the control and direction of air forces engaged in large area operations or those of global nature but not in close air support.

UNIVERSAL TRANSVERSE MERCATOR (UTM) GRID SYSTEM

When the UTM is used for referencing, the world is divided into large areas, called *grid zones*. Each of these grid zones is given an identification consisting of a number and a letter called the *Grid Zone Designation*, or GZD. The grid zones are subdivided into 100,000-meter squares, based on the grid covering the area. Each square is identified by two letters called the *100,000-meter square identification*. This identification is unique within the area covered by the GZD. The identification system for the grid zones and 100,000-meter squares is described below.

Between 84° north and 80° south, the globe is divided into grid zones 6° west-to-east by 8° south-to-north. Starting at the 180° meridian, the columns (6° wide) are numbered 1 through 60 in an easterly direction. The rows (8° high) are identified by letters. Starting at 80° south and proceeding to 84° north, the rows are lettered alphabetically C through X with the letters I and O omitted. The northern-most grid zone X is 12° high. To determine the grid zone designation of any 6° east to west by 8° south to north area, read RIGHT and UP. This principle has been condensed into a memory phrase for reading UTM coordinates, known as READ RIGHT UP. (See figure 5-12.)

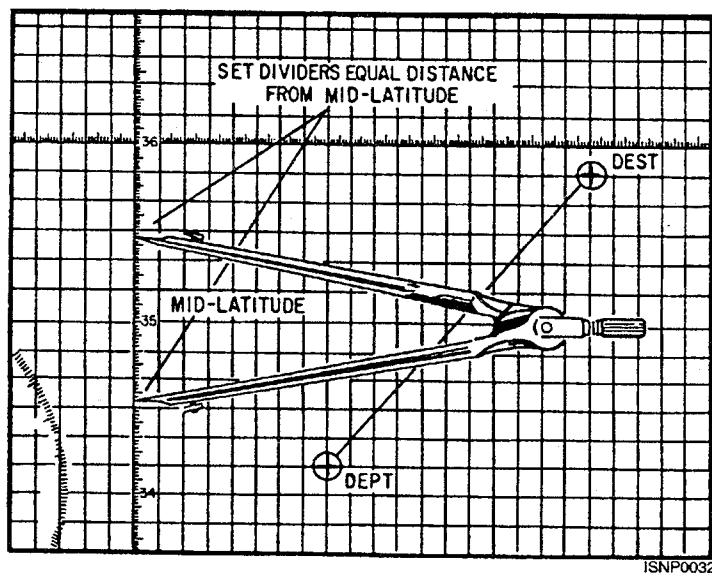
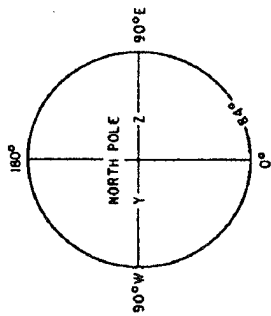
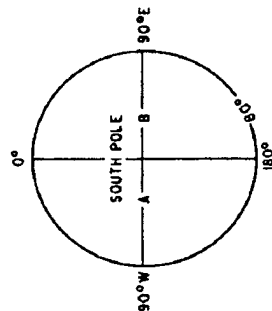
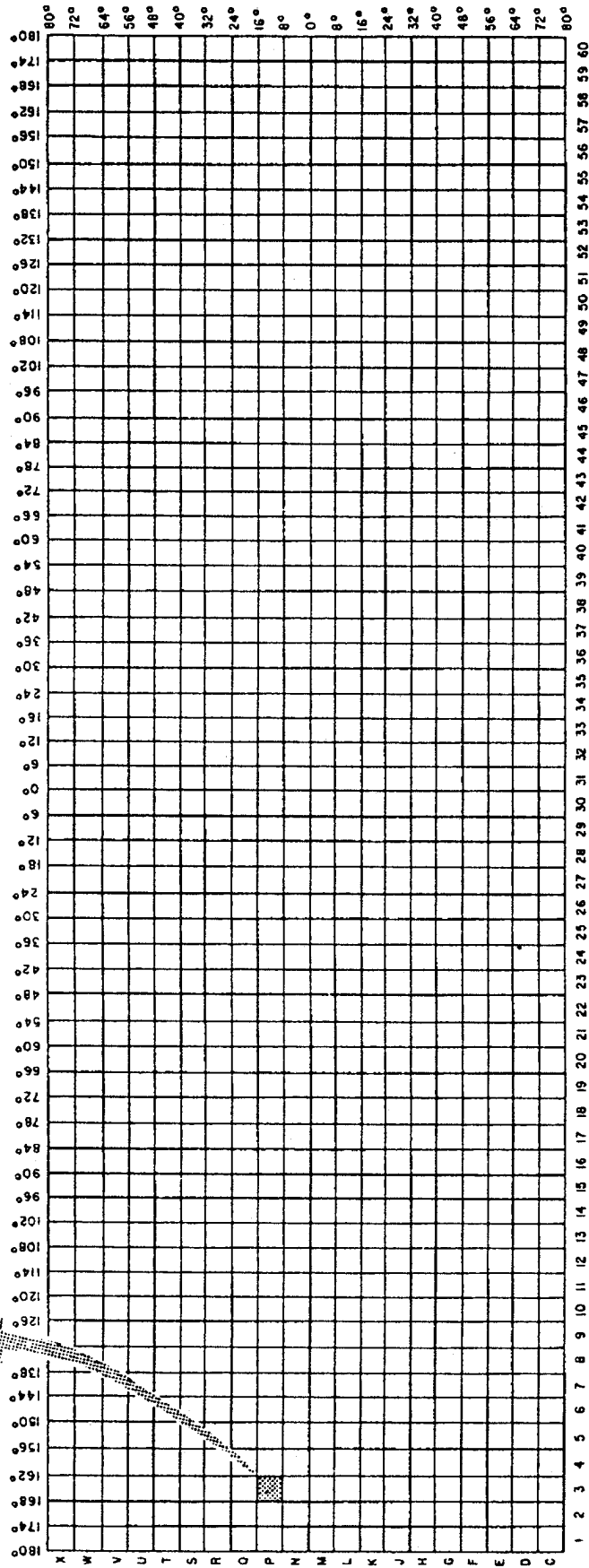

Figure 5-11.—Mid-latitude scale.



3P



ISNP0033

Figure 5-12.—UTM grid system.

The polar areas are divided into two parts by the 0° and 180° meridians. The half containing the west longitudes in the north polar region is given the grid zone designation "Y." The part containing the east longitudes is given the grid zone designation "Z." In the south polar region, the half containing the west longitudes is identified by "A." The east longitudinal half is identified by "B." No numbers are used in conjunction with the letters. (See figure 5-12.)

Between 80° south and 84° north, each grid zone is divided into 100,000-meter squares. Each column of squares is identified by a letter; also, each row of squares is identified by a letter. The number of complete 100,000-meter squares within a 6° by 8° area varies according to the position of the area on the globe. The system used in laying out and lettering the 100,000-meter squares is rather involved. (See figure 5-13.)

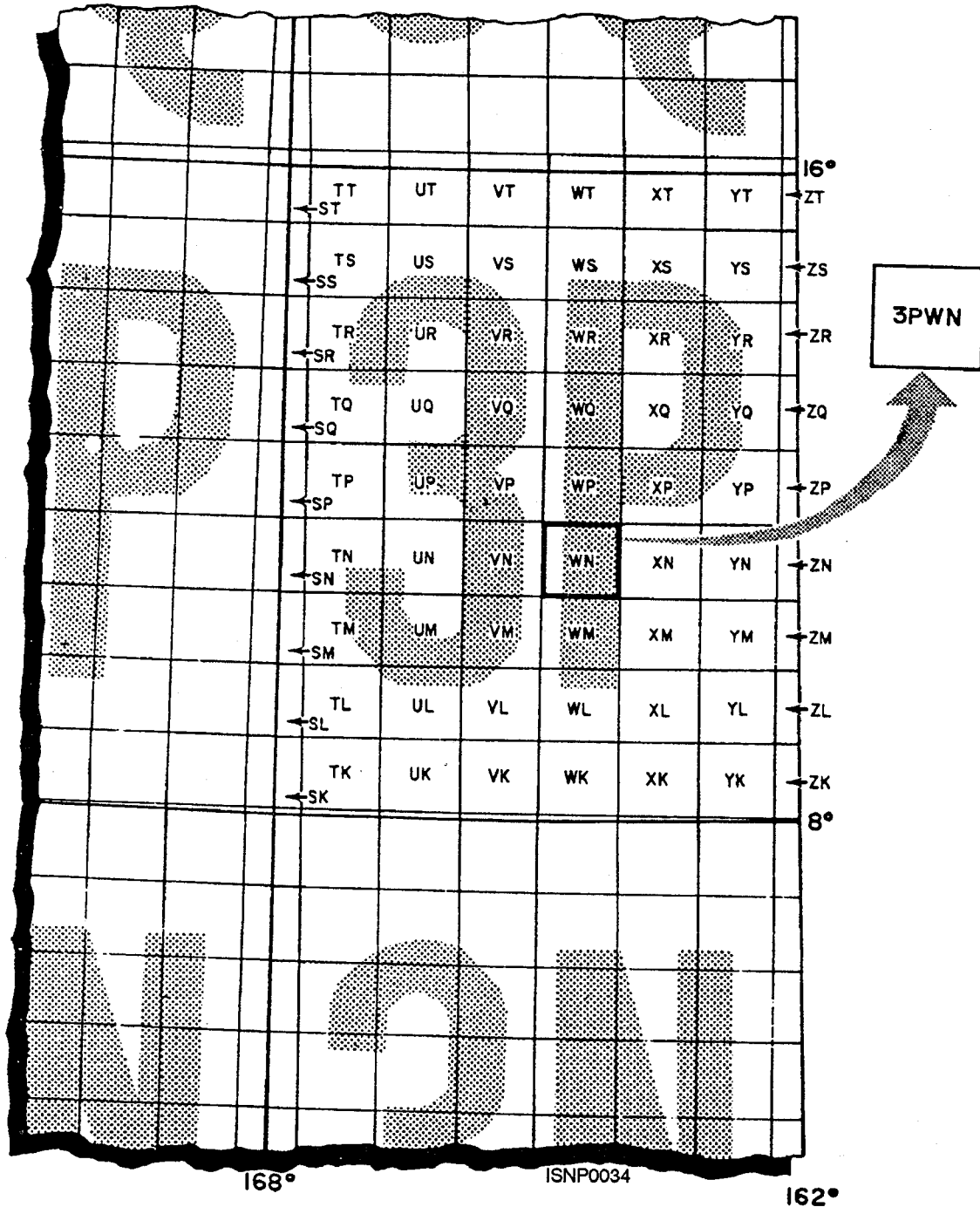

Figure 5-13.—Identification of a 100,000-meter square.

The identification of a 100,000-meter square consists of two letters determined by reading right and up, first its column letter and second its row letter.

A grid reference consists of a group of letters and numbers that indicate the grid zone designation, the 100,000-meter square identification, and the grid coordinates of a point or area expressed to the desired accuracy. A reference is written without spaces,

parentheses, dashes, or decimal points. Look at figure 5-14. This figure illustrates various-size areas located within grid zone 3P. Each square is located with the next larger square. Notice that as the area of interest gets smaller, the grid reference gets larger because the coordinates must be more specific.

The majority of the maps and charts that you will use have a grid overprint. A grid reference box

GRID REFERENCE

LOCATED AREA

● 3P (SEE FIG. 5-28)----- RECTANGLE, 8° LATITUDE, 6° LONGITUDE

● 3PWN (SEE FIG. 5-28)----- 100,000 - METER SQUARE

● 3PWN55----- 10,000 - METER SQUARE

NORTHING
EASTING

50,000

● 3PWN5354----- 1,000 - METER SQUARE

NORTHING
EASTING

4000

3000

● 3PWN539544----- 100 - METER SQUARE

NORTHING
EASTING

400

900

● 3PWN53925443----- 10 - METER SQUARE

NORTHING
EASTING

30

20

● 3PWN5392454432----- 1 - METER SQUARE

NORTHING
EASTING

2

4

ISNP0035

Figure 5-14.—UTM grid breakdown.

(figure 5-15) will appear in the margin of the map. The grid reference box keys the grid system to the map and also provides a sample reference with a step-by-step aid in using the grid. The grid reference box is normally printed in the same color as the grid overprint on the map to avoid error or confusion.

UNIVERSAL REFERENCE GRID (URG) SYSTEM

The URG system is used to define point locations on photography as linear coordinate positions. The grid, shown in view A of figure 5-16, is composed of a network of vertical and horizontal lines, which are assigned numerical values representing distances in centimeters from the established reference points.

The reference point on vertical and oblique photography is determined as follows:

Vertical photography— The reference point is located at the extreme left point of the trailing edge relative to the direction of flight. The trailing edge of the photograph is the axis of the horizontal line (or X axis), and the left edge of the print is the axis of the vertical line (or Y axis), as shown in view B of figure 5-16.

Oblique photography— The reference point is located at the lower left corner of the photograph when the horizon is oriented at the top. The bottom of the photo is the axis of the horizontal line (or X axis), and the left edge forms the axis of the vertical line (or Y axis), as shown in view C of figure 5-16.

The complete photo format is used in determining the reference point. Coordinates are always determined at the scale of contact prints. A single reference point is used for a complete photograph, even though some cameras use a split negative.

In practice, it maybe advantageous to construct a grid on a transparent film base, thus aiding in the rapid determination of positions. The grid is prepared by ruling lines at 1-centimeter intervals and numbering them from the reference point, as shown in view A of figure 5-16.

If possible, coordinate references should be defined to 1/10 centimeter, such as X 15.3/Y 02.7. When such close definition is not possible, the reference should indicate the lower left corner of the 1-centimeter square in which the point of interest lies, not the nearest intersection of grid lines.

ARBITRARY GRIDS

Arbitrary reference systems are used when no grid is available or practical or when military security for the reference is desired.

The Inch-Square Reference System is widely used on air-target materials. This system uses a network of parallel and perpendicular lines 1 inch apart. The origin is the southwest or lower left corner of the map or photo. If possible, the lines are oriented to true cardinal directions. The origin is numbered 00, and each line right and up is numbered 01, 02, 10, 11, and so forth, for as many inches as necessary. The coordinates may be read either to the nearest inch or tenth of an inch. For

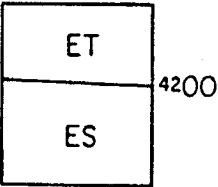
<p>GRID ZONE DESIGNATION: 16S</p> <p>100,000 M. SQUARE IDENTIFICATION</p> <div style="text-align: center;">  </div>	<p>TO GIVE A STANDARD REFERENCE ON THIS SHEET TO NEAREST 100 METERS</p>	
<p>IGNORE the SMALLER figures of any grid number; these are for finding the full coordinates. Use ONLY the LARGER figures of the grid number; example: <u>4193000</u></p>	<p>SAMPLE POINT: INDIAN MOUND</p>	
<p>1. Locate first VERTICAL grid line to LEFT of point and read LARGE figures labeling the line either in the top or bottom margin, or on the line itself: Estimate tenths from grid line to point:</p> <p>2. Locate first HORIZONTAL grid line BELOW point and read LARGE figures labeling the line either in the left or right margin, or on the line itself: Estimate tenths from grid line to point:</p>	<p>88 5</p>	<p>04 4</p>
<p>SAMPLE REFERENCE:</p>	<p>885044</p>	
<p>If reporting beyond 100,000 meters or if sheet bears an overlapping grid, prefix 100,000 Meter Square identification as:</p>	<p>ET885044</p>	
<p>If reporting beyond 18° in any direction, prefix Grid Zone Designation as:</p>	<p>16SET885044</p>	

ISNP0036

Figure 5-15.—Grid reference box.

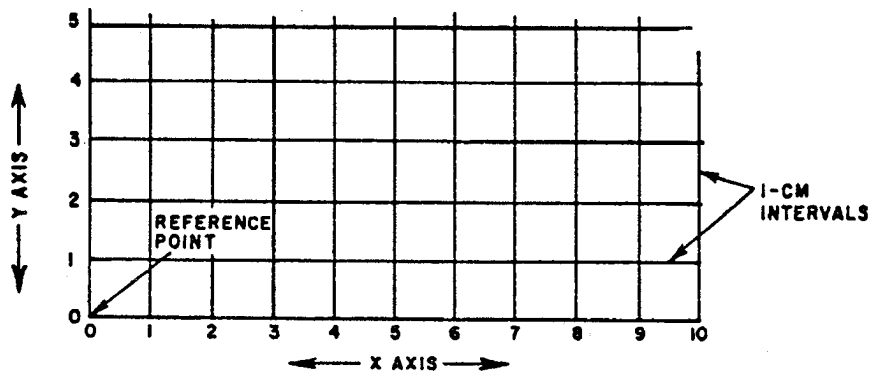

(A) UNIVERSAL REFERENCE GRID (URG)

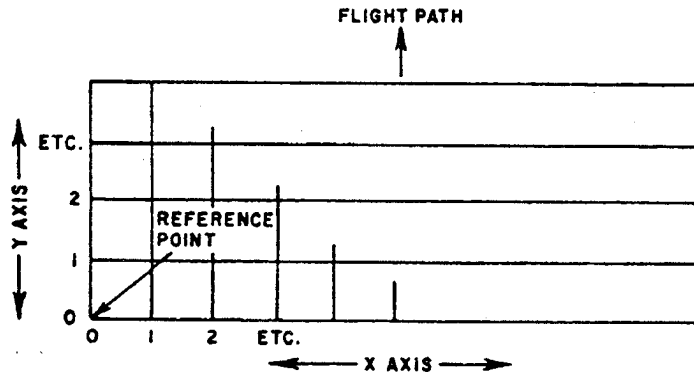

(B) URG FOR VERTICAL PHOTOGRAPHY

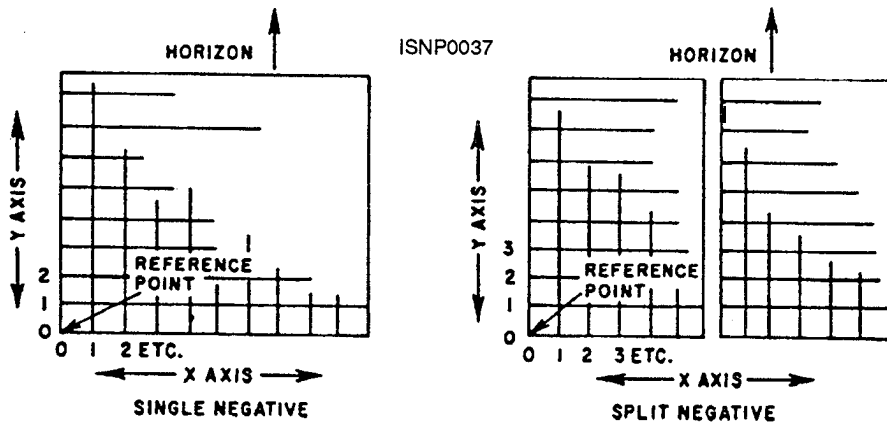

(C) URG FOR OBLIQUE PHOTOGRAPHY

Figure 5-16.—Location of reference points for the URG system.

example, 041132 indicates a point 4.1 inches to the right of and 13.2 inches up from the origin. When this reference system is used, the map or photo used must also be identified.

Thrust-Line Reference System

The Thrust-Line Reference System is used mainly by ground forces and has the advantage of good military security. This system uses a straight line, called the

thrust line, drawn between two arbitrarily selected points, the "starting point" and the "objective point." Directions to the right and left of the thrust line are designated by prearranged single letters. Any convenient unit of measure may be used. When there is a bar scale, the units on it are often used; otherwise, the unit may be inches. A reference is made by giving the number of units along the thrust line, the letter indicating direction from the thrust, and last the number of units along a perpendicular from the thrust to the

The Thrust-Line Reference System is only authorized for use on ungridded maps.

WORLD GEOGRAPHIC REFERENCE (GEOREF) SYSTEM

The GEOREF is based on the normal latitude and longitude values that appear on all maps and charts. Basically, this system defines the unit geographic area in which a specific point lies. The GEOREF may be applied to any map or chart, regardless of projection. It is read to the right and up in all cases. The numbering system runs to the right (eastward) from the 180th meridian around the globe (360°) to the 180th meridian again. It extends upward (northward) from the South Pole to the North Pole.

The GEOREF divides the Earth's surface into quadrangles of longitude and latitude by a simple, brief, systematic code that gives positive identification to each quadrangle. (See figure 5-18.)

The 24 longitudinal zones of 15° each are lettered from A through Z (omitting I and O) and extend eastward from the 180th meridian. This is shown in figure 5-19. Twelve bands of latitude, each 15° wide

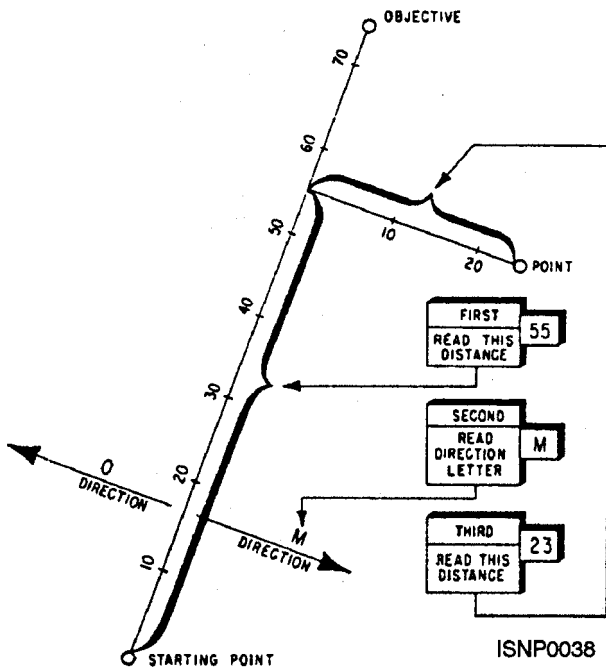

Figure 5-17.—Thrust-line grid.

point. (See figure 5-17.) Note that all users must know the starting point, the objective point, the single letters indicating direction from the thrust line, and the units of measure,

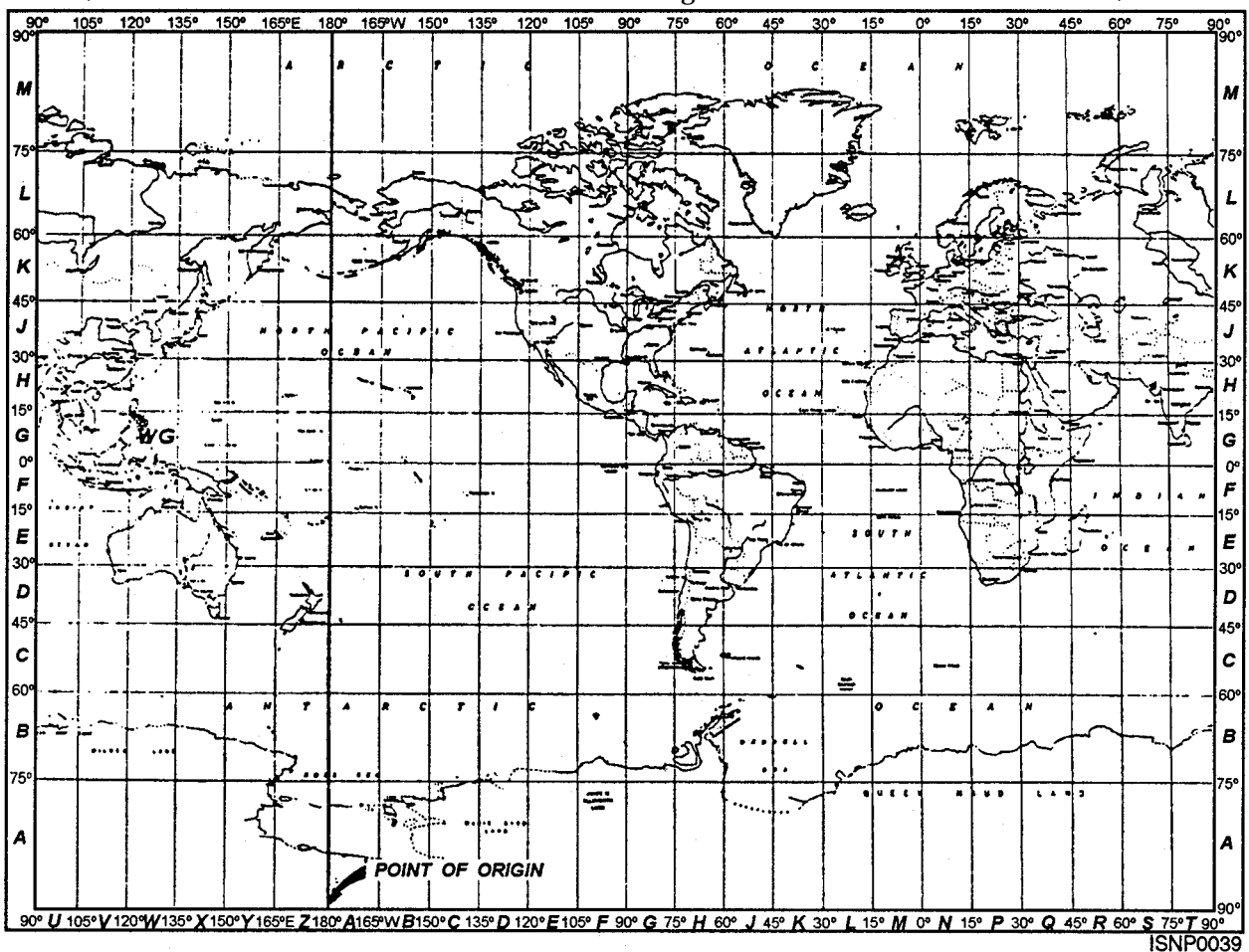

Figure 5-18.—World Geographic Reference System.

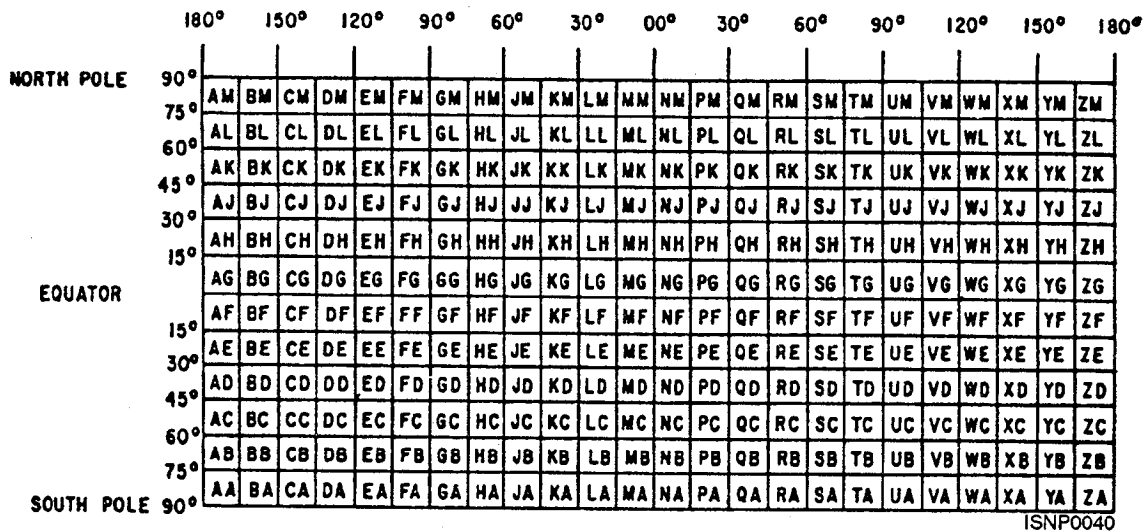

Figure 5-19.—Quadrangle system.

and lettered from A through M (omitting I), are spaced northward from the South Pole. This combination divides the Earth's surface into 288 basic 15° quadrangles. Each quadrangle is identified by two letters that refer to the lettered lines intersecting at the southwest corner of the quadrangle. In local operations that are confined to a single chart or to a single 15° quadrangle, these letters may be dropped for abbreviation. On small-scale charts that show large

areas, the letter designators are shown in the southwest corner of each 15° quadrangle. On large-scale charts, the 15° quadrangle designators are shown in the margin.

Each basic 15° quadrangle, in turn, is divided into 15 lettered 10 quadrangles eastward and 15 lettered 1° quadrangles northward, each axis lettered from A through Q (omitting I and O). Figure 5-20 shows the 1° quadrangle AN from the WG quadrangle.

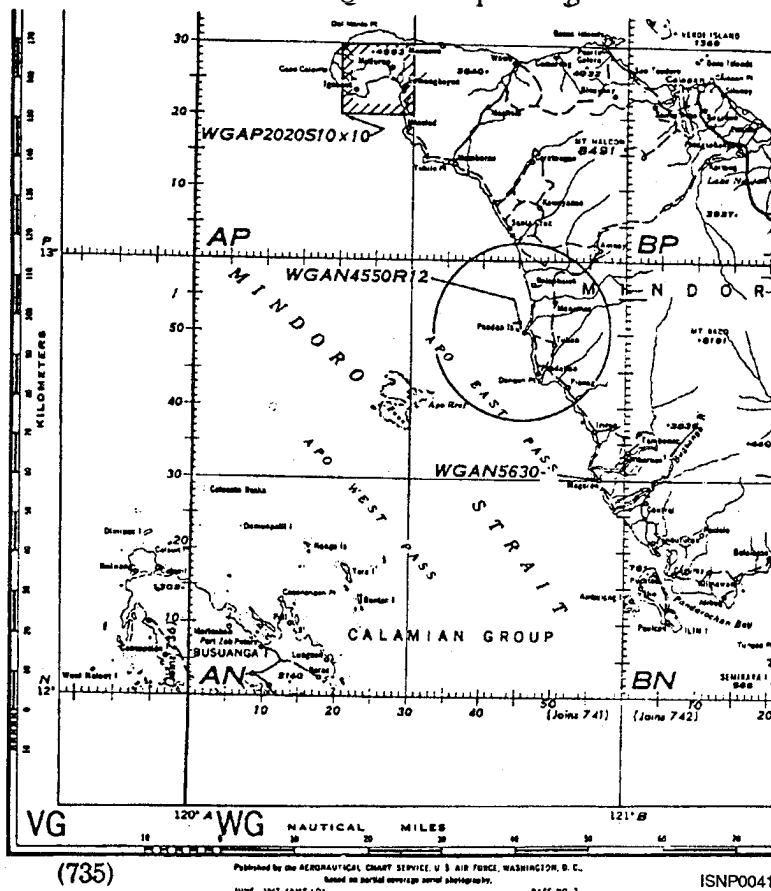

Figure 5-20.—Locating a point with GEORGEF.

Thus, two additional letters (four in all) will identify any 1° quadrangle in the world. These designators are shown adjacent to latitude and longitude values and lines on aeronautical charts. The 10 quadrangle designators also are shown in the southwest corner of each 10 quadrangle.

Each 10 quadrangle is divided into 60 numbered “minute” units eastward and northward. Thus, four letters and four figures will identify a 1-minute quadrangle anywhere in the world. This breakdown permits location of a point within approximately 1 nautical mile.

Designating Areas

To designate a square area, use the GEOREF coordinates of the southwest corner of the area, such as WGAP2020, to identify a point. Refer to figure 5-20. Then add the following: an “S” denoting “side,” digits denoting the number of nautical miles that the area extends to the east (following the principle of “right and up”), an “X” denoting “by,” followed by digits denoting the number of nautical miles that the area extends to the north (up). An example of a reference designating such an area is WGAP2020S 10X10.

To designate a circular area, use the GEOREF coordinates of the center area. Then use the letter “R” to denote “radius,” and add digits denoting the radius in nautical miles. For example, R 12 indicates a circular area 12 nautical miles in radius from the GEOREF point. An example of a reference designating such an area is WGAN4550R12. (See figure 5-20.)

Areas having shapes other than squares, rectangles, and circles do not lend themselves to simple coding. Therefore, to define such areas, you must give the coordinates of each “corner” of the area.

Designating Altitude

To designate an altitude plane in a GEOREF coding, follow the area reference with the letter “H” denoting “height of the plane above area level,” then add digits denoting the thousands of feet of altitude. Thus, “H10” denotes “altitude 10,000 feet above mean sea level (MSL).” For example, a geographical area 1 minute square at an altitude of 36,000 feet above sea level above the town of Magaran (figure 5-20) is written WGAN5630H36. If you need greater precision than to the nearest thousand feet of altitude, you may add additional digits to denote hundreds or tens of feet. For example, three digits denote thousands and hundreds of

feet of altitude: “H367” is read “altitude 36,700 feet MSL.” An altitude of 5,250 feet MSL is read “H0525.”

MARGINAL INFORMATION

While the central portion of a map shows an area of the Earth’s surface, the border area of the map contains a wealth of information, without which the map is all but useless. The information varies widely, but the marginal data most commonly includes the following:

- Symbol legend;
- Map identification information, such as the sheet name and number, map series, edition number, and date;
- Source information and reliability;
- A glossary of terms, including foreign terms when used;
- The scale, given in both numerical and graphic form;
- Relief;
- The projection used in constructing the map;
- Altitude or depth tint legend;
- Coverage diagram;
- Index to adjoining sheets;
- Grid information;
- North arrow, both true and magnetic;
- Correction notes;
- Date of information; and
- Security classification, when applicable.

We will now discuss in detail the most important of these items that we have not already discussed.

SYMBOLS

By their nature, maps are much smaller than the actual areas they represent. This size reduction creates a problem of how to show all the important objects as well as the changes and variations of the land. There must be some way to portray these objects simply and accurately. This problem is solved through the use of symbols. Many of the symbols used are common to the majority of maps and charts in common usage, but there is a vast quantity of symbols that are peculiar to

specialized maps, such as aeronautical charts. These symbols are shown in the marginal sections of the map. Many of the most common symbols are shown in appendix V of this manual. Of all the symbols, those indicating man-made features cause the most problems for interpreters.

As a general rule, symbols are printed on the map in one of the following four colors:

- **Black**— indicates man-made (cultural) features.
- **Green**— indicates areas of vegetation.
- **Brown**— indicates elevations.
- **Blue**— indicates water in various shades of blue.

Yellow, purple, or shades of red may be used on some charts to portray cities or radar-significant structures that are found on certain targeting charts. Purple is used for aeronautical information, whereas black or blue is used for grid overprints.

Topographic maps contain symbols and other types of information that are not normally found on other types of maps and charts. These include

- the classification of roads;
- the location and elevation of survey reference points, such as bench marks; and
- the delineation and classification of vegetation and wooded areas.

Generally, topographic maps are more precise and detailed than the other types of charts of an equivalent scale.

Aeronautical charts also have, in addition to general symbols, symbols and other information not used on any other type of chart. The majority of the symbols are required for navigation, and include airfield and navigational aid symbols; airway delineation and identification information; and, in some cases, radar-significant features.

Nautical charts are concerned primarily with hydrography. Their symbols provide information, such as soundings, channel markings, tides, currents, and bottom composition. Nautical charts usually present very little information concerning topography and man-made structures. They do, however, provide limited information on the location and description of specific features that, because of their size and location, make them readily identifiable and useful for taking bearings in navigation. Many modern nautical charts exhibit shaded relief representations and contours for

radar navigation. Others show complete cartographic detail that agrees with topographic maps because these charts are designed for use in amphibious operations.

IDENTIFICATION

The marginal area of each map contains specific information for identifying that particular map sheet. Of primary importance is the map (or chart) number and the series to which the map or chart belongs. This information is keyed to a publication, such as the DOD *Defense Mapping Agency Catalog of Maps, Charts and Related Products*, Parts 1 through 7. These publications index maps and charts by type, such as Operation Navigation Charts (ONCs), and provide a graphic outline showing the area covered by each map or chart. They also provide all information necessary to identify a map or chart.

The index lists the latest editions of all maps and charts. Whenever you use a map or chart, be sure to check its edition number against the latest edition of the index. Aeronautical and nautical charts are revised frequently, as they contain extensive navigational information that must be kept up-to-date. Accordingly, the charts contain a note block in the marginal areas giving the date of the navigational information printed on the chart. Subsequent changes are not shown until the next revised printing is distributed. You can correct nautical and aeronautical charts by using regularly issued summaries and notices.

A small diagram identifying the adjoining charts is sometimes placed in the marginal area. The index is invaluable for quickly determining these charts. However, a particular normally indicates only those charts available from the same producing agency, of the same scale, and in the same series.

SOURCE INFORMATION AND RELIABILITY

Many maps, particularly those of foreign origin, have as their base an older map of questionable reliability. A marginal note lists the source and date of the basic information as well as any effort to update the information.

In some instances, specific areas of the map may have been updated by surveying or photomapping. If so, a reliability coverage diagram will outline those areas according to reliability.

GLOSSARY

Maps that have a foreign base often contain foreign language wording for general terms, such as river, town, village, and mountain. To help you avoid confusing these terms with the proper names shown on the map, a glossary is often printed in the marginal area. This glossary is essentially a short bilingual dictionary giving the foreign term and its English equivalent and contains only the terms found on the particular map.

SCALE

We discussed the methods of depicting scale earlier in this chapter. Military maps and charts normally show both an RF and a graphic bar scale in the lower margin.

RELIEF

Objects and features on the ground are indicated on the map by symbols. What are the height and shape of the ground itself? How high are the hills? How deep are the valleys? In this discussion so far, we have not discussed the difference in height of various features found on a map. Because virtually every area on Earth contains some hills and valleys, we must somehow show them on maps. The paragraphs below explain the six methods most commonly used to show relief, or elevation. Those methods are also shown in figure 5-21.

Contour Lines

Of the six commonly used methods of showing elevation on a map, contour lines (view A of figure 5-21) are the most accurate and most generally used. A contour line represents an imaginary line on the ground along which all points are at the same elevation. Contour lines indicate a vertical distance above or below a datum plane. Starting at sea level, normally zero contour, each contour line represents an elevation above sea level. The vertical distance between adjacent contour lines is known as the *contour interval*. The contour interval is given in the marginal information. On most maps, contour lines are printed in brown. Starting at zero elevation, every fifth contour line is a heavier line. These heavy lines are known as *index contours*. Somewhere along each index contour, the line is broken, and the elevation is given. The contour lines that fall between the index contours are called *intermediate contours*. They are drawn with a finer line than the index contours and usually do not have their elevations given.

By using the contour lines on a map and the following procedure, you can determine the elevation of any point:

1. Find the contour interval of the map from the marginal information, and note both the amount and unit of measure.
2. Find the numbered contour line (or other given elevation) nearest the point whose elevation you want to know.
3. Determine the direction of slope from the numbered contour line to the point in question.
4. Count the number of contour lines that you must cross to go from the numbered line to the point and note the direction, up or down. The number of lines crossed multiplied by the contour interval is the distance above or below the starting value.

In addition to portraying elevation information, contour lines also give an indication of the general shape of the terrain. Remember that a contour line joins all points of equal elevation. For example, a contour line extends completely around a mountain or peak. By looking at several contour lines of a mountain represented on a map, you can visualize how that mountain actually looks.

Contour lines also indicate landform gradient or slope. They do this by how far apart they are spaced. For example:

- Contour lines evenly spaced and wide apart indicate a uniform, gentle slope.
- Contour lines evenly spaced and close together indicate a uniform, steep slope. The closer the contour lines are to each other, the steeper the slope.
- Contour lines closely spaced at the top and widely spaced at the bottom indicate a concave slope.
- Contour lines widely spaced at the top and closely spaced at the bottom indicate a convex slope.

Form Lines

Form lines (view B of figure 5-21) are another means of portraying relief on a map. A form line is not a contour line because it does not necessarily connect points of equal elevation and is not measured from any

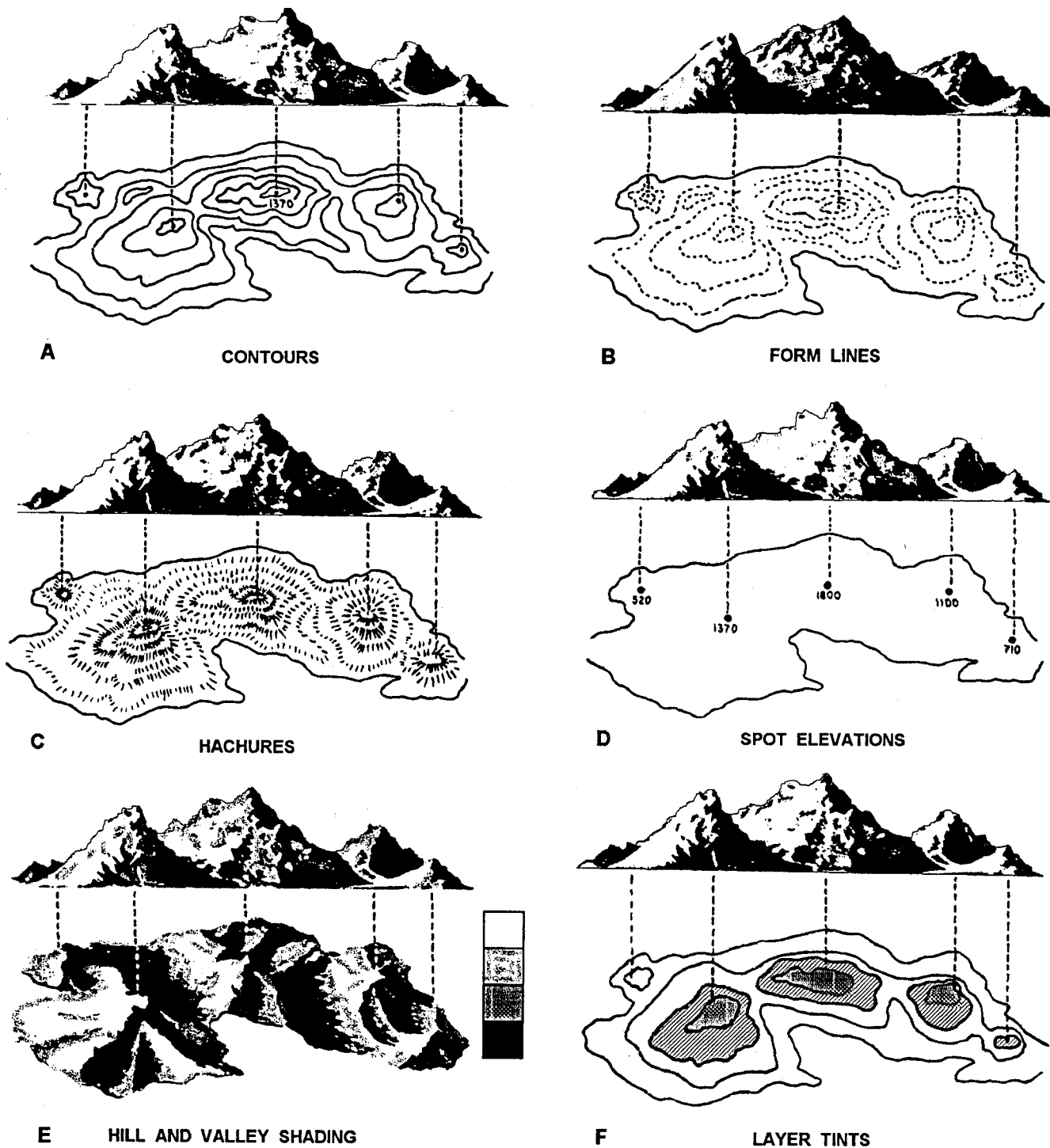

ISNP0042

Figure 5-21.—Methods of depicting relief.

base plane or datum. It gives only a general idea of relief and may be used when accurate data is not obtainable. Form lines have no standard elevation, although an attempt is made to draw them parallel to sea level and to space them according to the purpose of the map or sketch being prepared. Form lines are shown

as dashed lines and are never labeled with representative elevations.

Hachures

Hachures (view C of figure 5-21) are short lines used to indicate relief on a map, both in conjunction

with and independent of contour lines. They do not represent exact elevations but are used to show the general form and relative slopes of landforms. Hachures are used primarily to show large, rocky outcrop areas or other isolated land features that have abrupt changes in elevation or depression.

Spot Elevations

As a result of field survey operations in many parts of the world, the elevation above sea level has been established for a large number of points on the Earth's surface. For the most part, these points of known elevations, called *spot elevations*, are on the tops of hills and mountains or at distinctive cultural features, such as towns, cities, and road intersections. The portrayal of these known elevations, especially those of mountain tops, is standard practice on aeronautical charts.

A spot elevation (view D of figure 5-21) usually appears as a "dot" with a number indicating the accurately measured elevation of the spot above sea level. On some charts a small "x" is used to indicate an approximate elevation at a specific location. If the exact location of an elevation is unknown, only the figures are shown.

Hill and Valley Shading

Hill and valley shading is commonly referred to as "shaded relief" or "pictorial relief." This system of symbolizing topography, shown in view E of figure 5-21, portrays hills and valleys with shading in the manner used by an artist. Normally, the "light source" for the shading is considered to be at the northwest corner of the map sheet. The effect is pleasing to the eye and permits easy perception of landform profile because it accentuates mountainous areas. However, this type of shading does not give specific height data. Specific heights must be indicated by the addition of spot elevations and contours.

Color Tint/Layer Tint System

The color tint/layer tint system, used in conjunction with contours and shown in view F of figure 5-21, provides a means of quickly locating areas of high or low elevation. A "color box" is printed in the margin of every chart using the color tint system. This is arranged so that the color used on the chart to show a given "band" or "layer" of elevation (that is, 1,000-2,000 feet) is also printed between two labeled lines within the box. Varying degrees of green and

brown are used to show these different bands of elevation.

GREENWICH MEAN TIME (GMT) SYSTEM

When manned flights first began, they were short and usually remained in the same time zone. There were few, if any, problems with determining flight time. As flight distances increased, however, flight paths crossed several local time zones. For these longer flights, using the common civil time system for records, such as orders, reports, and logs, lead to many complications. A flight like the one shown below would have required several computations to determine total flight time. Additional problems would have arisen if adjustments for daylight saving time or other local variations had to be made.

Take off Jacksonville NAS	0900 eastern standard time
Land Scott AFB	1200 central standard time
Take off Scott AFB	1300 central standard time
Land Buckley ANGB	1600 mountain standard time
Take off Buckley ANGB	1700 mountain standard time
Land El Toro MCAS	2200 Pacific standard time

To prevent time computation problems and confusion, the Greenwich mean time (GMT) system was invented. The paragraphs below explain what GMT is and how to use it.

TIME ZONES

The local time zone system is built around the Greenwich meridian; that is, 0° longitude. The area between 7-1/2° east and 7-1/2° west is designated "zone Z." Since the system was originally conceived for use by ships at sea, the lines of zone demarcation are regular only at sea, and not necessarily even there. On land, the time zone boundaries are determined by national or international desires, which are influenced primarily by times of sunrise and sunset.

Working eastward from Greenwich (Z zone), local times become later by 1 hour for each time zone (approximately 15° longitude) passed through. (See figure 5-22.) The zones are lettered in alphabetical order from "A" through "M" (J is omitted). Working westward from Greenwich (Z zone), local times become earlier by 1 hour for each time zone (approximately 15° longitude) passed through. The zones to the west of Greenwich are lettered from "N" to "Y." Zone "M" to the east and "Y" to the west share the

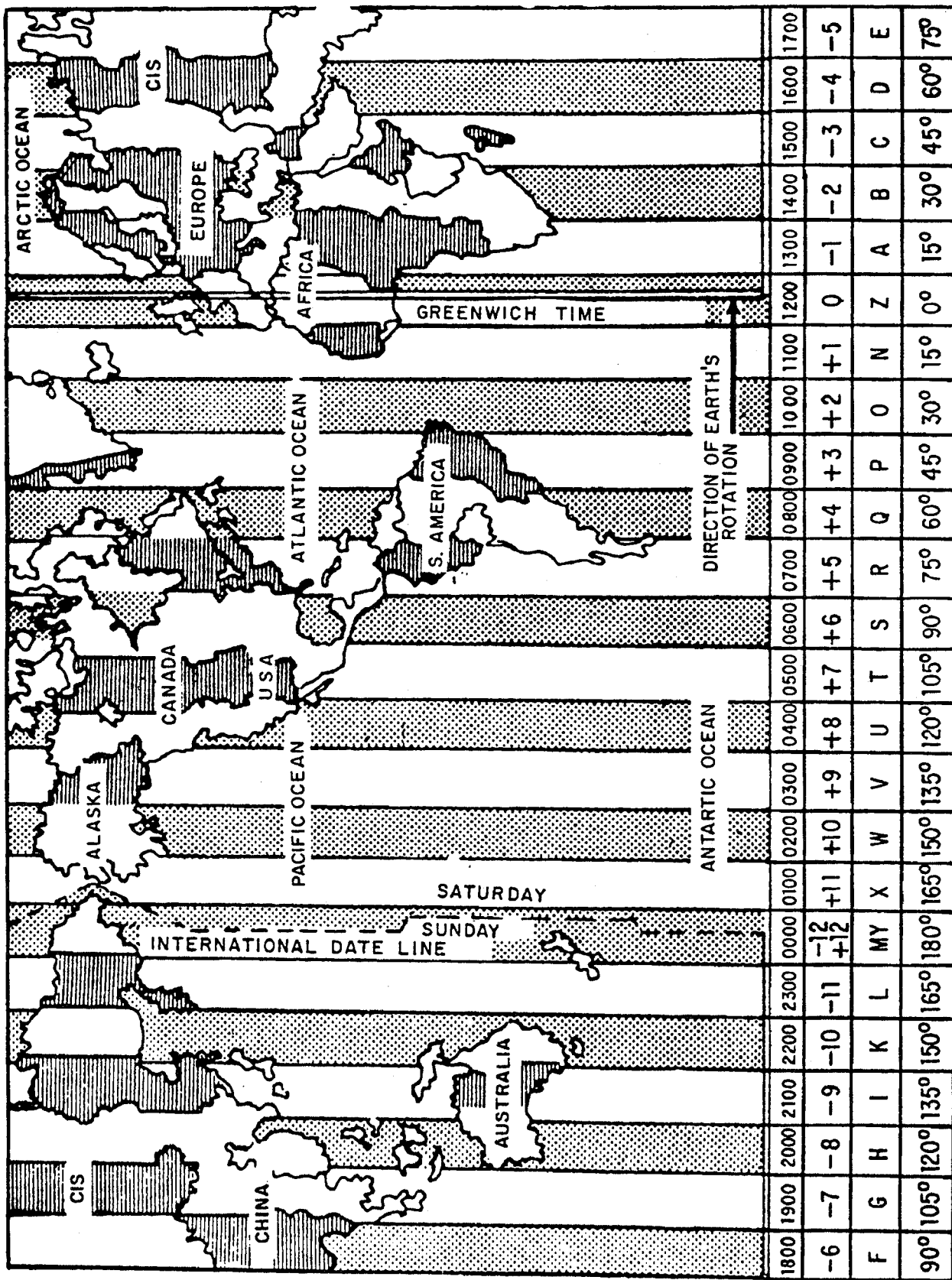

ISNP0043

Figure 5-22.—Time zone chart of the world.

same area; and in that zone, time computations are further complicated by the presence of the international dateline, which we will discuss later.

Each zone, in addition to having a letter identifier, also has a plus or minus number, known as the zone *description*. The plus and minus numbers indicate the difference between local time and GMT. Zones in the Eastern Hemisphere range from minus 1 to minus 12. To the west, the zone numbers are plus 1 to plus 12. Both minus 12 and plus 12 are found in the MY zone. The difference is not in the local time of day but in the day of the month and day of the week as determined by the international dateline.

To determine GMT in the Eastern Hemisphere, subtract the minus number from local time. To convert GMT to local time, add the number to GMT. To determine GMT in the Western Hemisphere, add the plus number to local time. To convert GMT to local time, subtract the number from GMT.

The most important thing to remember is that the plus and minus numbers indicate the figure, depending upon the hemisphere, to be added to or subtracted from local time to determine GMT.

The letter indicators of the zones give a simple identifier of the time referred to in communications. The letter is easier to transmit in code and may be spoken phonetically to ensure clarity in voice transmissions.

DATE-TIME GROUP

In most printed military communications, such as logs, journals, and other records, times are denoted in Greenwich mean time. Times are recorded in a *date-time group*. This figure is composed of six digits and a letter preceded by the month if any likelihood of confusion exists. The letter suffix for GMT is always "Z," sometimes read as ZERO, to indicate its zone description, and sometimes as ZULU, the phonetic alphabet word for "Z."

For example, consider this date-time group:
140100Z.

The first two digits are the date of the month, the other four, the time of day (using the 24-hour clock). The letter "Z" indicates GMT.

The greatest complication in the use of date-time groups is in keeping the date straight. When a local time zone system is used, the change of date occurs as the hour reaches 0001 hours. That particular time zone is the only time zone in which the date has changed at that

time. If the GMT system is used, however, the change occurs for the whole world as the clock hits 0001Z.

If the date is the 15th of the month, at 150001Z, a new day begins for London and for the GMT system all over the world. But according to local times, the time and date are 1901 on the 14th (141901R) in New York, 1601 on the 14th (141601U) in San Francisco, and 0201 on the 15th (150201B) in Moscow.

When the local time zone system is used, the date change occurs first along the international dateline, roughly the 180th meridian. Therefore, to compute GMT for local times in the Western Hemisphere, add a day if local time added to the zone's plus number totals more than 2400. In the Eastern Hemisphere, subtract a day if, after you deduct the zone's minus number, the remainder is a minus number (in other words, if the minus number is greater than the local hour figure).

Although this may seem confusing, it really is quite simple if you keep in mind that the GMT date-time group shows the time and date in the Z zone. Suppose local time in San Francisco is 201700 hours. The city is in the plus 8 zone. By adding 0800 to local time, we get 202500Z. Since we are working with a 24-hour clock, the figure is impossible. Since we know that Z zone assumes the new date in GMT before any zone in the Western Hemisphere, the correct time is 210100Z.

Similarly, suppose you are in the Philippine Islands with a local time of 220700. The GMT for this hour is 212300, since the Philippines are in the minus 8 zone. (0700 corrected by minus 8 equals minus 0100, which is 2300 on the preceding date.)

A frequent source of confusion is in juggling local times on either side of the international dateline. Suppose that you are in Tokyo and receive a message from Fairbanks, Alaska, with a date-time group of 061600W. You receive the message at 0711301. Actually, the message has taken only one-half hour to transmit since the two times could also be read as 070200Z and 070230Z. If you answer the message soon after receiving it, your date-time group might read 0712001 or 070300Z. Fairbanks might receive the message at 070330Z, which would still be on the 6th local time, or about 061730W. (Fairbanks is in the plus 10 zone; 061730 plus 10 equals 062730 or 070330Z.)

Most messages in present-day military communications use the Z date-time group. Your intelligence journal will cover 24-hour periods from 0001 to 2359Z. The logs kept by your navigators on missions will probably record items according to "Z" time. Operation orders, sighting reports, mission

reports, and most other business in air operations will use "Z time. Your reports to higher headquarters will most likely have to conform to the GMT system.

In your work in intelligence, you must know how to convert the local time and date in your zone to GMT and vice versa. You must also know the conversion figures for other zones with which you have communications contact in the event messages record in a time other than "Z time.

BASIC MAPS AND CHARTS

Now that we have discussed the basic projections, map characteristics, and scales used in cartography, let's consider briefly some of the maps and charts commonly used within the military intelligence community. Maps are generally categorized according to scale. Each scale series is intended to fulfill a specific type of map need. Each of these basic maps and charts is produced by the National Imagery and Mapping Agency (NIMA), formerly the Defense Mapping Agency (DMA).

GLOBAL NAVIGATIONAL AND PLANNING CHART (GNC)

The GNC is produced at a scale of 1:5,000,000 and is designed primarily for use in general planning for operations involving long distances or large areas of interest. This chart is often used for in-flight navigation by long-range, high-altitude, high-speed aircraft. Border lines of these charts are selected to consider primary areas of strategic interest, causing the charts to be used often as wall charts in briefing rooms.

GNCs show all pertinent hydrographic, topographic, and cultural features, including cities of strategic or economic importance, major towns, primary roads, railroad networks, and miscellaneous outstanding cultural features, including runway patterns of important airfields. The series also serves as the base for production of Global LORAN-C Navigation Charts (GLCCs) and Spacecraft Tracking Charts (NSTs).

JET NAVIGATION CHART (JNC)

The JNC is produced at a scale of 1:2,000,000 and is an all-purpose chart designed to satisfy the requirements of high-altitude, computer-assisted radar navigation/bombing by strategic aircraft. It depicts

such features as the transportation network surrounding major cities, as well as rail and road networks in other areas. There is also an aeronautical information overprint, including runway patterns of important airfields and other pertinent data. This series also includes Universal Jet Navigation Charts (JNUs), for use as plotting charts in the training for and the practice of celestial and dead-reckoning navigation.

OPERATIONAL NAVIGATION CHART (ONC)

The ONC is produced at a scale of 1:1,000,000. It is used for preflight planning and en route navigation and was designed particularly to satisfy military low-altitude navigation requirements. The ONC is used for operational planning, intelligence briefing and plotting, and for flight-planning wall displays.

TACTICAL PILOTAGE CHART (TPC)

The TPC is produced at a scale of 1:500,000 for low-level, detailed, preflight planning and mission analysis. Ground features significant to visual and radar checks and low-level, high-speed navigation are emphasized. Detail includes cities, towns, principal roads, railroad networks, power transmission lines, and miscellaneous cultural features significant to low-altitude missions. Aeronautical information emphasizes airfields. Hard-surface runways over 3,000 feet long are symbolized by a runway pattern. Also depicted are all vertical obstructions over 200 feet high.

JOINT OPERATIONS GRAPHIC-AIR SERIES 1501 (JOG-AIR)

The Series 1501 JOG-AIR is the aeronautical chart version of a coordinated worldwide series, 1:250,000 scale, required to support international and joint service air/ground tactical operations, preflight and operational planning, training, pilotage or operational functions, and intelligence briefings. Spot elevations, to provide terrain elevation data, are depicted for air operations. Detail includes pattern of cities, towns, roads, trails, and railroads. Additionally, miscellaneous cultural features, boundaries, and power transmission lines are depicted. Aeronautical information includes airfields by runway pattern, stable radio navigation and communications facilities. Known obstructions over 200 feet above ground are shown with above sea level

and ground level elevations. The interchart relationship of ONCs, TPCs, and JOGs is shown in figure 5-23.

TOPOGRAPHICAL MAP

The final type of map with which you should be familiar is the topographical map intended primarily for use by ground forces. Its accuracy and wealth of information also make it a valuable intelligence tool for the imagery interpreter. The distinguishing characteristic of topographical maps is the portrayal of landforms and terrain elevation. The map records, in convenient, readable form, the physical characteristics of the terrain as determined by precise engineering surveys and measurements. It shows the location and shape of mountains, valleys, and plains; the network of streams and rivers; and the principal works of man.

MAP OVERLAYS

Overlays are translucent sheets of paper or clear sheets of acetate containing symbols not normally found on maps. On the overlay, everything is already plotted for the benefit of the receiver or user. The user quickly orients the overlay to the correct map or photography, and the desired information is immediately available. Thus, the use of an overlay is a good method of accurately transmitting military

information pictorially rather than by a lengthy message.

Overlays are used frequently by ground forces for sending plotted positions of enemy installations from one headquarters to another. Air units, such as fighter and bomber units, often work in close coordination with ground units. Therefore, from time to time, air units use or receive overlays from a ground force commander outlining a forthcoming military operation. In such cases, the overlay tells the same story pictorially that would otherwise have required a lengthy narrative description and a listing of coordinates.

An overlay has at least two advantages over a written message. One is additional secrecy. An overlay is transmitted by courier, whereas written messages are usually sent by mechanical means and are subject to enemy interception. The second advantage is clarity. Once placed in position on the proper map, the overlay "tells its own story" in the exact manner that the narrator wishes it to be told.

Overlays can also be produced through the use of computers and digital plotters. An advantage of this method of producing overlays is the short time involved. They are also extremely accurate.

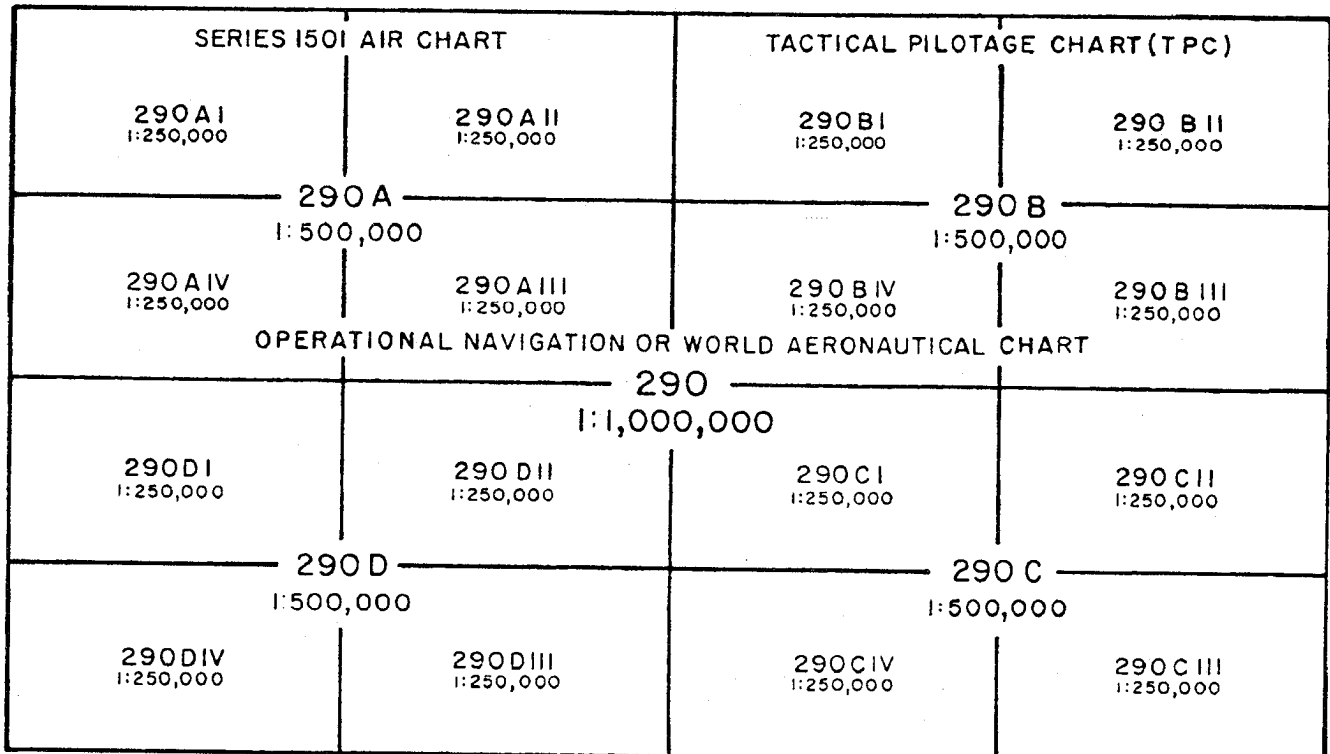

ISNP0044

Figure 5-23.—Interchart relationship diagram for ONCs, TPCs, and JOGS.

TYPES OF OVERLAYS

Generally, there are two types of overlays: *intelligence* and *operational*.

Intelligence Overlays

Intelligence overlays contain information about an enemy situation, such as the disposition of forces; types of units; flak areas; and the location of depots, supply installations, command posts, and airfields in the areas covered by the map. This information is shown by the use of military symbols.

Operational Overlays

Operational overlays contain information about the friendly situation, such as the disposition of forces, command posts, supply points, and railheads. These are also shown by the use of military symbols.

MILITARY SYMBOLS

Overlays and situation maps provide a rapid and easily understood means of showing an operational plan, concept, or friendly or enemy situation. However, standardization of techniques is essential if tactical information is to be presented without misunderstanding. Standardization is provided by the use of standard military symbols.

Ground Order of Battle overlays and situation maps require the marking of the location of various units with their appropriate symbols, as shown in *Military Symbols*, Army Field Manual FM 21-30.

A military symbol is a sign, composed of a diagram, number, letter, abbreviation, color, or combination of all of these, that is used to identify and distinguish a particular military unit, activity, or installation.

Military symbols are used with all types of overlays, situation maps, aerial photographs, and organizational charts to identify items of operational interest accurately. Departure from the standard symbols presented in FM 21-30 is generally discouraged. If symbols must be improvised, they must be shown and explained in an accompanying legend. Military symbols lose their value if they become complicated or cluttered with unnecessary detail. The purpose and level of command and the tactical situation determine the amount of information required to represent military units and installations adequately. When you use military symbols on overlays and graphics, you should strive to show only essential

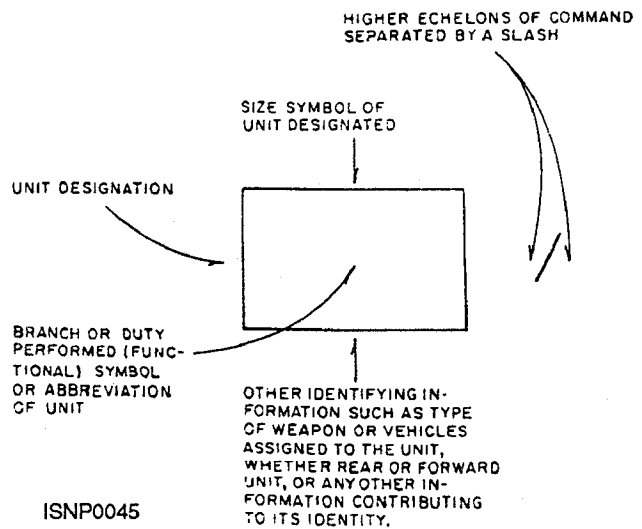

Figure 5-24.—Developing the unit symbol.

information, keeping in mind that simplicity, uniformity, and clarity are the keys to good military symbology.

Basic Symbols

Geometric figures form the basic symbols used to represent units, installations, and activities. In this section, we will discuss only the basic UNIT symbol. The development of all other basic symbols is fully explained in FM 21-30.

The basic unit symbol is a rectangle that has supplementary information added to it to indicate the unit size, the branch or duty performed, the unit designation, and other required information that will aid in identifying the unit. The basic unit symbol is developed as shown in figure 5-24. An example of a completed unit symbol is shown in figure 5-25.

When colors are used in conjunction with military symbols, the following color standards apply:

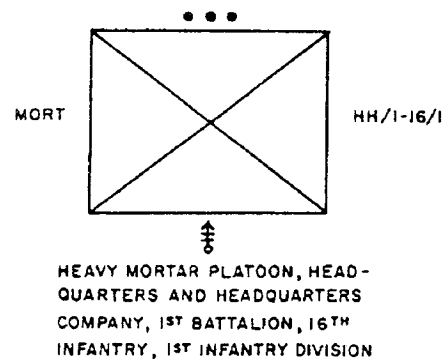

ISNP0046

Figure 5-25.—Completed unit symbol.

Blue or black— friendly units, installations, equipment, and activities;

Red— enemy units, installations, equipment, and activities;

Yellow— friendly or enemy areas of chemical, biological, or radiological contamination;

Green— friendly or enemy man-made obstacles.

If colors other than the four standard colors are used, a suitable explanation must be given in an accompanying legend. If only a single color is used, friendly symbols are outlined with single lines and enemy symbols are outlined with double lines. (See figure 5-26.)

MATERIALS REQUIRED FOR OVERLAY CONSTRUCTION

The basic materials required to prepare overlays are some type of transparent base, such as frosted or clear acetate or tracing paper and inking and lettering pens or devices for adding the required information. Other specialized materials, such as rub-off letters and other symbols and colored tapes may also be used.

Acetate

The most widely used base material for constructing overlays is clear acetate, which is normally available in either sheet or roll form. Acetate is easily

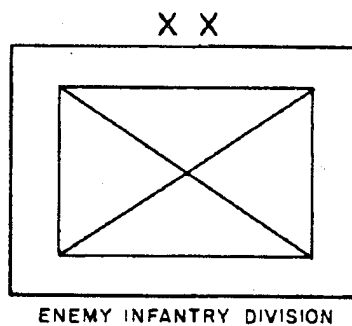
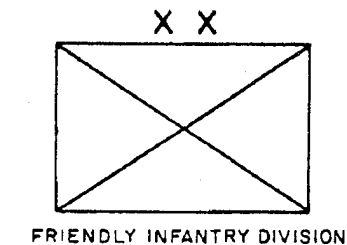

ISNP0047

Figure 5-26.—Military symbol construction, single-color method.

cut with scissors or a razor blade. Adhesive materials, such as tapes, rub-off letters, and cements adhere to it readily.

Rub-Off Letters

Rub-off letters, numbers, symbols, patterns, and colors imprinted on thin, transparent, plastic sheets are sold under several trade names. They have a waxed coating on the reverse side to act as an adhesive when the material is pressed firmly onto any smooth surface. Because the sheets are available in such a wide variety of symbols, numbers, and colors, they are especially useful in annotating overlays and graphics. A few types can be obtained printed with standard military symbols, such as missiles, radar, aircraft, and ships.

Rub-off lettering is applied to an overlay or graphic by positioning the selected sheet as desired and then pressing the symbol or letter firmly into place, either with the aid of a bone burnisher or some other firm, rounded object.

When properly applied, rub-off lettering provides a professional appearance to overlays and graphics with a minimum expenditure of time.

Colored Tapes

The correct application of plastic tapes, just as rub-off lettering, can aid in the preparation of overlays and graphics. The tapes are available in a wide assortment of colors, patterns, and symbols and in widths ranging from one sixty-fourth of an inch to several inches. Tapes can be a valuable tool for you. Colored tapes are useful as a means of depicting tracks, boundaries, and in delineating areas of interest. The same type of standard military symbols mentioned above are also available in various colors and sizes.

OVERLAY PREPARATION

Overlays may be prepared on a map or photobase. Photography is a second choice, because photography, as opposed to a map, normally shows only the enemy situation. Whenever you consider using photography, remember that the command that receives and uses the overlay may not have copies of the photographs involved, while they normally will have the required maps. Also, only rarely does all of a combat area appear on a single photograph, whereas it may be shown on a single map.

Prepare the overlay as follows:

1. Orient the map so that the data is in a readable position.
2. Place the overlay paper or acetate over the map so that the data is covered and the margin is sufficient for registration marks, title block, and perhaps binding into a report.
3. Position the title block in the lower right-hand corner so that it will not interfere with information to be recorded.
4. Register the overlay according to the base used. Indicate at least two opposite, intersecting grid lines or geographic coordinate lines. Be sure to label these lines with the correct geographic or grid coordinates.
5. Plot the information to be presented on the map base by the following methods:
 - a. Use standard symbols when possible. If you must use nonstandard symbols, show and explain them in an accompanying legend.
6. Complete the title block, including the following information:
 - a. Title or purpose of the overlay (defense, transportation, and so forth);
 - b. Area identification (name, coordinates and/or Basic Encyclopedia numbers);
 - c. Complete map identification (series, name, sheet number, edition, date, and scale);
 - d. Organization and individual preparing the overlay;
 - e. Date the overlay was made; and
 - f. Appropriate security classification.
7. Add a north arrow, and indicate whether it is true grid, or magnetic north.

Figure 5-27 shows an example of a map overlay.

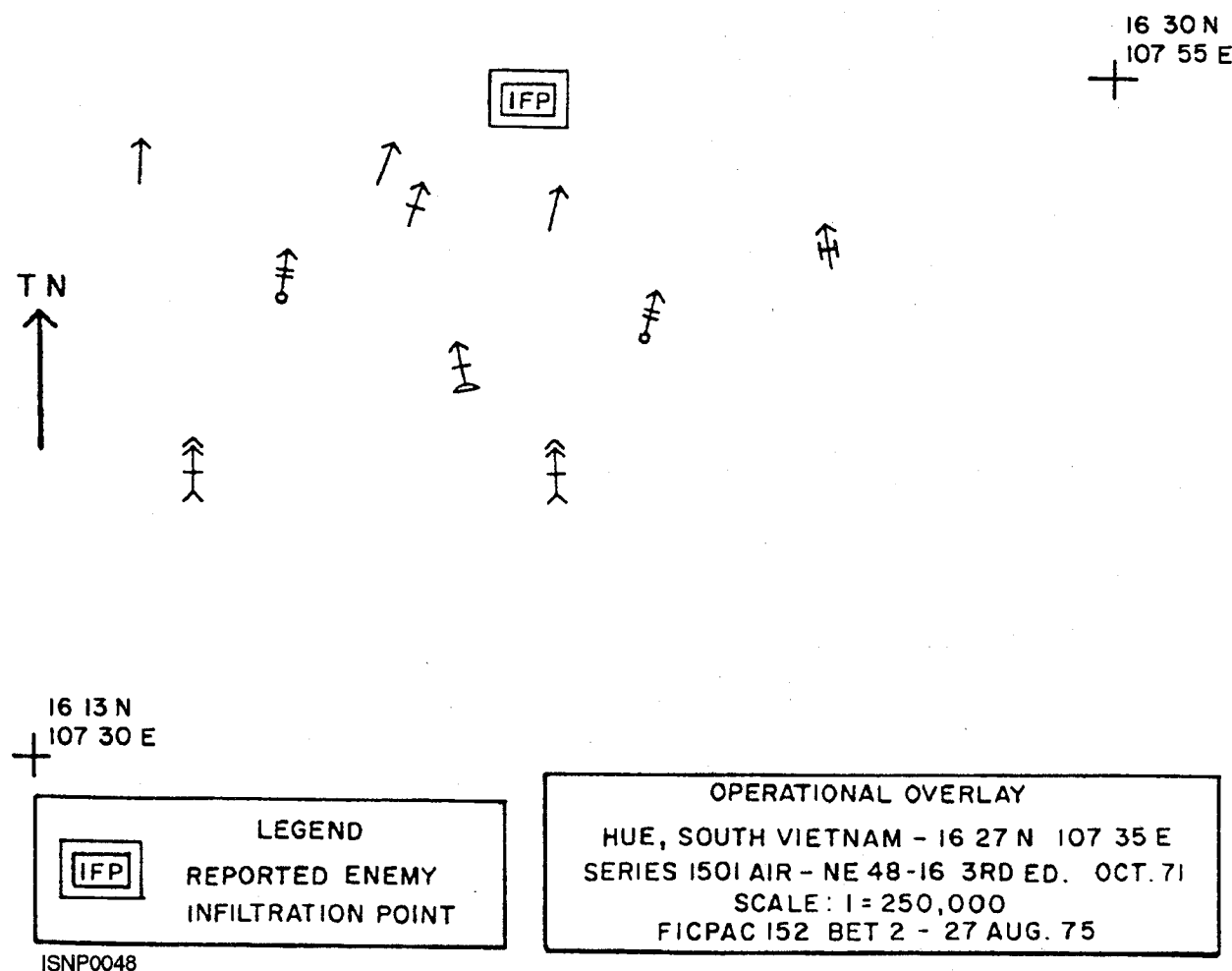

Figure 5-27.—Map overlay example.

MAP AND CHART DEVELOPMENT AGENCIES

Maps and charts of varying types and scales are published for the Armed Forces. They include the latest available information for use in navigation, pilotage, intelligence, and ground operations. They are designed for both tactical and strategic use.

NATIONAL IMAGERY AND MAPPING AGENCY (NIMA)

The National Imagery and Mapping Agency (NIMA) was established in October of 1996, incorporating the mission and functions of the Defense Mapping Agency (DMA) and several other intelligence organizations. Although the scope of NIMA's mission includes the management of all imagery exploitation, production and distribution, in this chapter we will discuss only the mapping, charting, and geodesy (MC&G) responsibilities.

NIMA operates as a combat support agency of the DOD. Its mission is to enhance national security and support the Office of the Secretary of Defense, the Chairman of the Joint Chiefs of Staff, Unified commands, military departments, and other users by producing and, through the Navy supply system, distributing MC&G products and services.

NIMA Components

The NIMA has approximately 7,500 employees in more than 50 locations around the world. The MC&G functions of NIMA are conducted principally by its three major production (mapmaking) centers. They are: NIMA Aerospace Center (NIMAAC), NIMA Hydrographic/Topographic Center (NIMAHTC), and NIMA Reston Center.

The NIMA Systems Center is responsible for advancing the agency's capability of producing products through the use of soft-copy or computerized production techniques.

The agency also operates the Defense Mapping School. This school provides training in all aspects of MC&G.

NIMA Catalog

The NIMA *Catalog of Maps, Charts, and Related Products* is organized as follows:

- Part 1—Aerospace products;
- Part 2—Hydrographic products;
- Part 3—Topographic products;
- Part 4—Target material products;

- Part 5—Submarine navigation products;
- Part 6—Special-purpose products; and
- Part 7—Digital data products.

Flight Information Publications (FLIPS) and Related Products is produced as Part 1, Volume 1, of the NIMA catalog.

Other NIMA Publications

Several other publications that deal with maps and charts are of particular importance to you:

NIMA BULLETIN DIGEST.— The *NIMA Bulletin Digest* is a semiannual cumulative summary that provides information for users to verify their inventories, assuring the latest editions are held, and to confirm the completeness of their holdings. They exist for both classified and unclassified catalogs.

NIMA CHUM&CHUM SUPPLEMENT.— The *NIMA Aeronautical Chart Updating Manual (NIMA CHUM)* is a listing of additions, discrepancies, and special notices used by personnel to make pen-and-ink changes to aeronautical charts to keep them current. The CHUM is published semiannually in two volumes. A CHUM supplement is published monthly in each of the intervening months.

PROCURNG AND STOWING MAPS AND CHARTS

Maps, charts, and related products are managed by the NIMA headquarters in Bethesda, MD. Requisitions are submitted through the Navy supply system and are consolidated at base-, installation-, wing-, division-, or ship-level throughout DOD. Maps and charts are ordered by Navy Stock Numbers (NSNs) and are routed through the appropriate supply channels for your command. Future distribution may flow through the Defense Logistics Agency (DLA); however, the exact areas of responsibility have yet to be determined.

Navigational maps, charts, and related publications and periodicals are obtained according to the requisitioning procedures presented in the general information section of each volume of the NIMA catalog. This section identifies uniform procedures for the preparation and submission of requests to NIMA for aeronautical, nautical, and topographic maps, charts, and related publications. Consult the NIMA catalog for detailed preparation instructions.

REQUISITIONING NIMA PRODUCTS

Requisitions for NIMA products should be prepared on one of the following standard

documents/software programs designed for data entries by machine, typewriter, ballpoint pen, or pencil:

- Joint Message Form (DD Form 173)—AUTODIN/MILSTRIP format. Message requisitions are acceptable from authorized requisitioners, provided they are in the format

shown in figure 5-28. AUTODIN/MILSTRIP transmissions must be unclassified. NIMA encourages the use of AUTODIN for routine and priority requisitions. AUTODIN is fast, efficient, economical, and minimizes manual processing.

ISNP0049

SECURITY CLASSIFICATION																																		
JOINT MESSAGE FORM					UNCLASSIFIED																													
PAGE	DTG/RELEASE TIME			PRECEDENCE		CLASS	SPECAT	LMP	QC	ORG/MSG IDENT																								
	DATE TIME	MONTH	YR	ACT	INFO																													
01 of 01	030939Z	JUN	93	RR		UUUU		TC	IAZZ																									
BOOK	MESSAGE HANDLING INSTRUCTIONS																																	
<p>FROM: CDR XVIII ABN CORPS FT BRAGG NC//DS-MAP//</p> <p>TO: DAAS DAYTON OH</p> <p>UNCLASS</p> <p>SUBJ: MILSTRIP REQUISITION</p> <table border="0"> <tr> <td>A0DHM80TPCXD10A</td> <td>EA00001W36B5W31540001R</td> <td>DNS</td> <td>09</td> </tr> <tr> <td>A0DHM801501ANH5109</td> <td>EA00025W36B5W31540002R</td> <td>DNS</td> <td>09</td> </tr> <tr> <td>A0DHM80WQXZP7154</td> <td>EA00002W36B5W31540003R</td> <td>DNS</td> <td>09</td> </tr> <tr> <td>A0DHM8014BHA14427</td> <td>EA00003W36B5W31540004R</td> <td>DNS</td> <td>09</td> </tr> <tr> <td>A0DHM80M745XL3718</td> <td>EA00015W36B5W31540005R</td> <td>DNS</td> <td>09</td> </tr> <tr> <td>A0DHM80Y942XZANZIBAR</td> <td>EA00002W36B5W31540006R</td> <td>DNS</td> <td>09</td> </tr> </table> <div style="border: 1px dashed black; padding: 10px; text-align: center; margin: 20px auto; width: 80%;"> <p>SAMPLE—DO NOT COPY</p> <p>REFER TO INSTRUCTIONS</p> </div>											A0DHM80TPCXD10A	EA00001W36B5W31540001R	DNS	09	A0DHM801501ANH5109	EA00025W36B5W31540002R	DNS	09	A0DHM80WQXZP7154	EA00002W36B5W31540003R	DNS	09	A0DHM8014BHA14427	EA00003W36B5W31540004R	DNS	09	A0DHM80M745XL3718	EA00015W36B5W31540005R	DNS	09	A0DHM80Y942XZANZIBAR	EA00002W36B5W31540006R	DNS	09
A0DHM80TPCXD10A	EA00001W36B5W31540001R	DNS	09																															
A0DHM801501ANH5109	EA00025W36B5W31540002R	DNS	09																															
A0DHM80WQXZP7154	EA00002W36B5W31540003R	DNS	09																															
A0DHM8014BHA14427	EA00003W36B5W31540004R	DNS	09																															
A0DHM80M745XL3718	EA00015W36B5W31540005R	DNS	09																															
A0DHM80Y942XZANZIBAR	EA00002W36B5W31540006R	DNS	09																															
DISTR:																																		
DRAFTER TYPED NAME TITLE OFFICE SYMBOL PHONE						SPECIAL INSTRUCTIONS																												
MAJ MICHAEL ANDREW, G-2, 0879																																		
TYPED NAME TITLE OFFICE SYMBOL AND PHONE						SECURITY CLASSIFICATION		DATE TIME GROUP																										
COL PAMELA CHRISTINE G-2 0675						UNCLASSIFIED		030939Z JUN 93																										
SIGNATURE																																		

6
5
4
3
2
1
0

Figure 5-28.—DD Form 173 example.

- **SF 344—Multiuse Standard Requisitioning/Issuing Document.** NIMA prefers the use of this form for manual requisitions. An SF 344, shown in figure 5-29, should be used to requisition items not identified in the NIMA catalog or items for which the stock number is not known. Mail it to the designated supply source identified in the NIMA catalog.
- **GETAMAP PROGRAM.** GETAMAP is a NIMA software program that is provided to NIMA customers free of charge. This easy, menu-driven software program reduces the time to prepare an order, increases the correctness of the order, reduces requisition processing time, and eliminates delays encountered in mailing orders to NIMA. Refer to the NIMA catalog for complete details on the latest methods and upgrades to this system.

The responsibility for proper routing of charts and publications to the departments within an activity rests with the commanding officer, and all materials are addressed to him or her. To aid in handling these materials and to expedite delivery, the delivery address should be marked for the attention of the unit intelligence officer.

STOWING MAPS AND CHARTS

Aeronautical charts are normally folded and packaged when they are received and do not require further folding. NIMAHTC charts may occasionally be received flat, and unless an activity has a definite requirement for flat stock charts, the charts should be folded for stowage.

All maps and charts should be stowed by series and then in the proper numerical order within the series. The storage shelves should be properly marked to aid in the rapid location of required materials. It is essential that an accurate and efficient inventory system be used for accounting for all materials on hand.

Each chart that is held should be listed, giving both a high and low quantity allowance. When the quantity drops below the low limit set, an additional supply should be ordered to bring the number on hand up to the high limit. As charts are expended, the listing of the quantity on hand should be corrected. As new supplies are received, the edition that is received should be checked against both the one listed on the control card and against the materials available in stock. Obsolete materials should be removed immediately and

classified editions destroyed according to current regulations.

Prior to a deployment or major exercise, sufficient charts of the subject area should be ordered to ensure delivery prior to departure and to ensure that it will not be necessary to request an emergency requisition of these materials.

A regular and systematic inventory of all charts ensures that the correct quantities and latest editions are stocked. One satisfactory system is to divide the total chart stowage into 12 groups, ensuring that 1 group is completely inventoried each month. Thus, the entire supply is checked annually.

INTELLIGENCE CHARTS

The preparation of daily intelligence can be made a great deal easier if the information is presented graphically. The intelligence chart is the best means to do this. Briefings are much more meaningful if graphic aids are used to help listeners visualize the lengthy verbal description and statistics that must be presented.

In a tactical mission brief, whether for a combat mission or training mission, severe time limitations restrict intelligence personnel to disseminating only essential information. The material used is usually limited to annotations on charts; projections of selected photographs; and, in the case of critical or difficult-to-locate targets, tracings or handouts of the target area.

MOUNTING PROCEDURES

Mounting procedures vary, depending on your location and the availability of resources. The mounting can be as simple as clipping or tacking a map or chart to a cork board or as elaborate as affixing many maps or charts to form a large area of coverage for detailed, recurring briefings. You must identify the surface, prepare your area, and collect all the necessary materials you'll need. Consult your command's standard operating procedures and the wealth of experience at your command for any assistance you might need.

IDENTIFYING THE SURFACE

Identifying the surface is a fairly simple task. If you are at a shore command, you will probably have many surfaces to choose from. If you're at sea, however, the surfaces will be a bit more limited and will depend greatly on the size of the unit. For example, the

STANDARD FORM 344

SF 344 WILL BE HANDLED AS ROUTINE

DOCUMENT IDENTIFICATION									
1	2	3	4	5	6	7	8	9	10
DOC. NUMBER	ROUTING	DATE	BY	REQUISITIONER	DATE	BY	REQUISITIONER	DATE	BY
ADD	HMB	0	W81U1W	3300					
SIGNATURE (If required) MR TOPOGRAPHIC READINESS BN MAP DEPARTMENT, DORRMANN IDEN 236-4360 BLDG 873056 A STREET FT. BRAGG, NC 28307-5000									
NOTE: Entries in shaded blocks may be in either the FIXED (F) or VARIABLE (V) sections—NEVER in both.									
REQUISITION DATA									
11	12	13	14	15	16	17	18	19	20
SEC	STOCK NUMBER	QTY	UNIT	DATE	BY	REQUISITIONER	DATE	BY	REQUISITIONER
	GNCX N36	EA	00004	0001					
	ONCX NE12	EA	00001	0002					
	TPCX N28C	EA	00039	0003					
	WPCX N021002	EA	00005	0004					
	BCNX E0101	EA	00001	0005					
	CONB T500743	EA	00001	0006					
	WJPC N504	EA	00001	0007					
	ENXZ A1243	EA	00001	0008					
	ETXZ N2194	EA	00001	0009					
	GAZG N2UBA	EA	00001	0010					
	TANT ABAN60K	EA	00001	0011					
	ESQJ NXG103	EA	00002	0012					
	WJEZ P500	EA	00010	0013					
	Z401 XALL	EA	00002	0014					
	Z4AN XALL	EA	00001	0015					

Include address, POC, telephone numbers, and signature

Priority IAW FAD-UND

D - Ship to Requisitioner

Note: This form provides for entries through field 65-66. Additional entries (fields 67-80) or special instructions must be annotated in REMARKS field.

See Ordering Procedures for mailing addresses.

ADD - Domestic Shipment
ADA - Overseas Shipment

Routing Identifier
HMB - DMASS/CCOR

Media and Status Code

DoDAAC

Julian Date

Stock Number
Series and Sheet

Quantity Requested

Serial Number

The use of Standard Form (SF) 344 should be limited to routine (Priority 09 - 15) Requisitions. Requisitions received by mail with priority designators 01 through 08 will be downgraded to 09.

ISNP0050

Users may obtain Standard Form (SF) 344 through their local supply source using National Stock No. 7540-00-965-2379.

Figure 5-29.—SF 344 example.

intelligence center aboard an aircraft carrier should have a variety of boards, whether they be metal, cork, or even poster board. Aboard smaller ships, the choices could be limited to cork or poster board. The variety will depend on the resources of that particular ship or unit.

PREPARING TO SURFACE

Preparing the surface is a natural follow on once you've identified the surface. It will depend on what surface you are using. When you affix large-scale charts to a metal backing, ensure that the surface is clean, so that the map or chart will not have lumps or uneven areas. If you use rubber cement or some other adhesive, be aware of the various safety and caution warnings. There are fleet restrictions concerning the use of these materials, so take care when using them. Cork and poster board require less preparation, due to the simple nature of their surfaces. The main point of preparation is to keep the surface clear of debris and to make the finished product as professional-looking as possible.

COLLECTING MATERIALS

The ease in collecting materials will depend on the resources available to you. The larger the command or unit, the easier it will be to collect the materials. At smaller commands or units, *you* will need to collect the items you'll need. This will be a test for your ingenuity and your ability to improvise. Whatever the case, your goal is to provide the most professional product your resources will allow. Some of the possible materials you'll require are identified below:

- Adhesive or tacking supplies;
- Clear or sticky back acetate;

- Poster board;
- Colored tapes and symbols;
- Grease pencils (different colors).

It will be beneficial to you to maintain a good relationship with your supply department and supply petty officer. It will also be helpful if you maintain a listing of the stock numbers or requisition numbers that were used in the past to order similar materials.

ANNOTATIONS

The methods used to annotate maps and charts are almost identical to the procedures we discuss in the next chapter of this manual. Because that chapter contains detailed information on annotation procedures, we will not cover them here. The type of annotation you use will depend on the size of the chart and exactly what type of information you need to label. Annotations include numbers, outlines, and symbols. The preparation of annotations and illustrative material varies with the service and unit.

SUMMARY

Having a basic understanding of maps, charts, and grid systems is essential for the Intelligence Specialist. You will use these skills in virtually all aspects of your job. This chapter has provided you with background information on the different types of map projections and scales, the methods used to identify geographic coordinates and other grid systems, and how to identify the various relief characteristics. It also discussed how to create and use overlays, provided information on the NIMA and how to requisition maps and charts, and explained how to prepare graphic material that will be used by an individual in giving an intelligence briefing or making a report.

CHAPTER 6

IMAGERY INTERPRETATION

LEARNING OBJECTIVES

Upon completing this chapter you should be able to do the following:

- *Explain the advantages and disadvantages of using photo reconnaissance imagery over other methods of gathering intelligence information.*
 - *Identify and explain the basic functions of imagery interpretation.*
 - *Identify the basic aids to interpreting aerial photographs and explain their use.*
 - *Describe the fundamentals of camera operation as they pertain to imagery.*
 - *Describe the procedures and techniques used in the collection of imagery.*
 - *Describe the procedures for retrieving imagery.*
 - *Describe the procedures used to request imagery from other agencies.*
 - *Recognize features of selected military platforms.*
 - *Describe the proper operating procedures and maintenance requirements for light tables.*
 - *Describe fundamental mosaic construction.*
 - *Describe the procedures for annotating imagery and mosaics.*
-

The imagery interpreter's main job is to derive from aerial or other imagery detailed information about the capability of a potential enemy to wage war. Few sources can provide as detailed, accurate, and up-to-date information as interpreters who are careful, know what they are looking at, and interpret what they see with intelligence rather than guesswork. With this information, a commander can estimate the military situation and determine sound courses of action.

Photographic reconnaissance not only prevents an enemy from keeping vital facts secret, but also establishes a permanent record (the photograph) that "freezes" the situation so it can be analyzed, checked, and rechecked later. Camouflage, natural foliage, natural concealment, or confusing shadows cannot prevent an alert imagery interpreter from detecting what an enemy is up to. The word "detecting" is appropriate because the interpreter is, in fact, an investigator,

discovering clues that may not be evident to the eye alone. Like any good investigator, the IS must remain objective, view problems dispassionately, and avoid trying to prove assumptions.

When photographs were first used to gather information about an enemy, their function was essentially to identify objects and help determine their significance. This process was called *imagery interpretation*.

Imagery interpretation has been expanded to include imagery intelligence, which is the art of evaluating and collating these individual interpretations into a completely valid concept of an enemy situation. To complete this imagery intelligence estimate, the IS combines his or her own information with that from other available sources.

IMAGERY INTELLIGENCE

The satellite and missile age has opened the door to new uses of imagery intelligence. The launching of imaging satellites and guided missiles shows the increasing importance of photographs as the primary source of intelligence about conditions over vast land areas.

ADVANTAGES

Aerial imagery has many advantages over other sources of information. Some of these advantages are as follows:

The situation can be permanently recorded, making it difficult for an enemy to camouflage or conceal his plans, activities, or equipment.

Unlike other methods, deriving information from imagery can be done by experts who work many miles distant under relatively undisturbed conditions. Their interpretation is free from personal bias and distortions, which may be characteristic of a ground observer working under trying conditions.

Imagery can provide information about otherwise inaccessible areas. In 1962, for example, aerial photography confirmed the presence of Russian missiles in Cuba, thus aiding President Kennedy's memorable decision to establish a naval blockade, which compelled the Russians to withdraw the missiles.

Imagery lends itself to accurate analysis. If some question of fact occurs, the imagery can be inspected as frequently as necessary—it does not change nor is it subject to fading memory. It can be compared, detail by detail, with previous and successive imagery of the same area to ensure accurate analysis and to follow the progress of enemy activities.

DISADVANTAGES

Despite the advantages of photographs, they do have their limitations. For instance, the IS cannot always see the finer details of a target. The existence, overall size, and extent of a target are relatively easy to determine. However, details, such as construction techniques and materials used in construction, are not that easily determined.

Aerial imagery reconnaissance is limited by weather, light conditions, availability of aircraft,

performance of film and cameras, and by the adversary. Each photograph records conditions for only a split second. Although studying the imagery from several missions over the same target gives the interpreter a timed comparison, he or she cannot observe the target continuously for any significant period of time.

A final drawback is the dependence on weather and the image taker's flight path. The observations of the imagery interpreter are limited to the areas shown on the photograph. If an important feature happens to be in an area just outside available photo cover or under a patch of clouds, the interpreter has no way to compensate for loss of the image.

Although the limitations we just described may cause problems, they shouldn't prevent you from determining facts that are not directly apparent on a photograph. You can collate your observations with the data available in other documents, reports, charts, and ground information. These sources supplement your photographic data, and, at the same time, the photographic data supplements or amplifies the sources. For example, changing terrain and cultural features may render obsolete the map information obtained in surveys of years before. Beach and coastal patterns and underwater depths in near shore areas are constantly changing. By correlating current photographic coverage with charts and deepwater surroundings, you can make a more accurate interpretation of existing conditions.

In the following section, we will examine how the IS, as an imagery interpreter, fits into the production and dissemination portions of the intelligence cycle.

IMAGERY INTERPRETATION FUNCTIONS

Your role as an imagery interpreter is many faceted. It demands detailed knowledge of an enemy's military capability and general knowledge of those areas that support that capability.

As the imagery interpreter, you are the bridge between intelligence sources and the intelligence consumers. You must be able to develop information on a wide range of subjects. Some of these include enemy defenses, airfields, and industries; terrain and beach conditions; and the immediate accuracy of maps and charts. You must also be able to develop information on targeting material in the form of text, graphics, and mosaics on which the commander's decisions for combat and strategic operations are based.

A photograph alone is worth little to planning. You are the link between the photograph and the report.

FUSION ANALYSIS

Interpretation of aerial imagery is the responsibility of specially trained individuals. They must understand thoroughly what constitutes significant intelligence information. With this in mind, they can collate, evaluate, report, and disseminate intelligence from the pertinent elements of information available. Imagery interpretation can be challenging, due in part to the vast amount of knowledge that can be gleaned from a single photograph. It requires personnel whose background and experience represent proficiency in many fields.

It is the skill and experience of IS personnel that determine the success or failure of their work. As an IS, you must know what to look for, be able to identify what you find, and know the significance of an object in its location. You must also be able to use effectively information from other sources, know how to use comparative imagery coverage, and know the enemy, his equipment, and his order of battle. To these general requirements may be added many specific ones, depending on the particular kind of interpretation involved.

DATA ANALYSIS

As an IS, you must devote a certain portion of your time to study in order to maintain and improve your proficiency. You must learn the general background information relating to the military situation, the political, geographic, and economic data on the area, and planned or projected future military operations. You must also keep abreast of specific development derived from imagery intelligence.

You must understand the enemy's situation and, in fact, be able to put yourself in the enemy's place and follow his reasoning. You must also become familiar with the characteristics of the enemy's capabilities, his industrial potential, his transportation facilities, the nature of the terrain and cities he occupies, and the many other facets of his culture.

To achieve this identification with an adversary's thought process, you must have a positive attitude and an objective approach. Common sense, disciplined study, research ability, experience, and attention to every detail are essential characteristics that an interpreter must possess in order to prepare and present a detailed and accurate analysis of photographic

intelligence. To accomplish these tasks, you must know what photography can and cannot reveal.

PHOTO IMAGERY CHARACTERISTICS

Since imagery interpretation involves the identification of an object from a photographic image, you must understand the characteristics of these images.

Shape

Shape relates to the general form, configuration, or outline of an object. Since aerial photography presents objects from an overhead perspective, the shape or form of an object is often a critical factor in its recognition. Straight lines and controlled curves on a photograph indicate man-made features; irregular lines indicate natural features. Ditches are straight, but streams are twisting. Railroads appear as long, straight tangents across terrain; but trails and back roads follow the easy contour route, blending with the landscape. Cultivated fields tend to be well-defined, regular shapes; shorelines and small bodies of water are usually irregular in design. Characteristic shapes make certain photo images readily identifiable. For example, the unique shape of the baseball diamond is easily recognized from overhead imagery.

Size

Size refers to the dimensions of an object on a photograph. For example, you can use railroad gauge (distance between rails) to determine the scale of the photograph if you know the gauge. You must usually identify objects from images that vary in size from one scale of photography to the next. Because of this, you should know the scale of the photography and frequently calculate the actual sizes of the objects represented. Many a photographic image has been misinterpreted on the basis of its shape alone. By using the relative size of objects, you reduce the chance that a certain image is a specific object. Conversely, you can positively identify certain objects by their size. For example, the relative width of a battleship is much greater than that of other ships that may be tied up nearby.

Pattern

Pattern refers to the spatial arrangements of objects. The repetition of certain general forms or relationships is indicative of certain situations. Whether the objects are natural or man-made, they can

establish a pattern that will aid you in recognizing them. You can usually recognize military installations by their pattern. For example, barracks and similar buildings are generally arranged in neat rows; mess halls and other service facility buildings are usually interspersed. The guns of an antiaircraft battery are normally set up in a certain, recognizable relationship to one another. Agricultural areas (rice paddies, wheat fields, orchards, and so forth) normally follow patterns suited to the terrain in which they are located. Figure 6-1 shows a valley that is crisscrossed with several patterns of black dots. Taken individually, the black spots on the photograph aren't very significant. However, when these spots are arranged in a regular pattern, they reveal the existence of a minefield.

Tone

Tone refers to the variation of light reflected by an object. Without this contrast, the shapes of objects could not be discerned on imagery. The photographic tone of an object is one of the best clues, and sometimes the only one, to its identity.

Black-and-white photography registers color in shades of gray, ranging from black to white. All other factors being equal, the tone for any given ground area or object depends on the reflecting power of its surface. Where the surface is fairly smooth, as in the case of concrete, the amount of light reflected is high. On the other hand, rough surfaces, such as forests or rocks, generally show darker tones because of the scattering

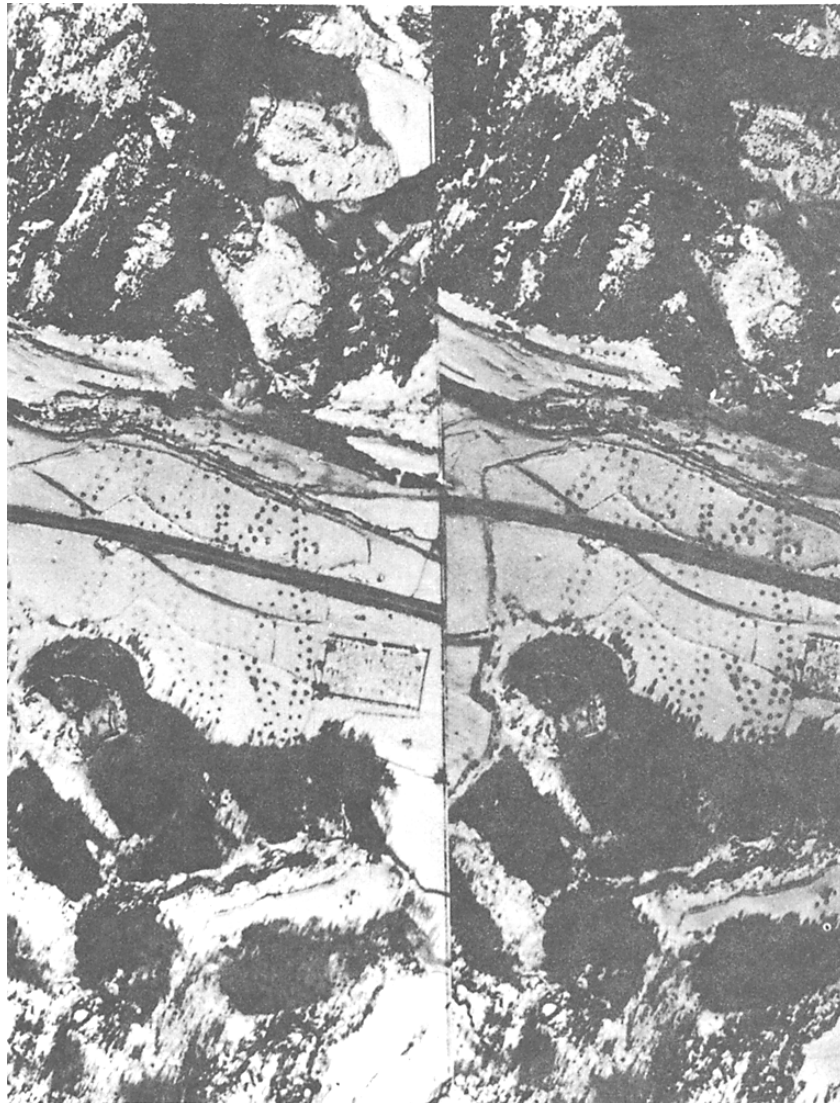

Figure 6-1.—Pattern.

of light and of the presence of tiny shadows interspersed with the reflecting surfaces. With certain associated knowledge, you can use tone to identify images on a photograph.

Texture

Texture, as applied to imagery, is defined as the frequency of tone changes within the image. Texture is the primary characteristic used in certain types of imagery interpretation. For example, the photographic texture of a beach area on which an amphibious landing is contemplated may indicate the coarseness of particles composing the beach and, thereby, the ability of the beach to support military vehicles.

The size of an object required to influence texture increases as the photographic scale decreases. For example, on large-scale photography of a wooded area, leaves of the trees contribute to the texture of the crown. On small-scale photography, crowns contribute to the texture of the overall timber stand. Regardless of tone or shape, the disparity in texture can give a definite indication of different types of vegetation and the ability to transverse the area. With considerable knowledge of vegetation, you can, solely by texture, identify types of vegetation in an aerial photograph.

Shadow

Shadow refers to a condition in which certain objects block sunlight from portions of a photograph. The shape of an object is generally revealed by its shadow, thereby providing a clue to its identity and size. The clearance of a bridge, as well as its type of structure, can often be interpreted from its shadow.

Shadows can hinder analysis by obscuring detail. However, this condition is offset by the additional information the shadow may contribute. For example, shadows may provide a silhouette of a ground object, thus revealing its profile characteristics.

All the photo image characteristics just discussed are interrelated and must be applied to each interpretation problem. As you gain experience in imagery analysis, you will see how these factors come together and how they contribute to the art of photo interpretation and the overall intelligence mission.

AIDS TO INTERPRETATION

The imagery interpreter's equipment usually includes a stereoscope, measuring scales, dividers, various magnifying devices, and selected computer

systems. The interpreter uses this equipment to provide either limited or dedicated support to mensuration and exploitation of soft-copy imagery. Interpreters serving aboard large imagery interpretation units may have access to more elaborate and precise equipment for measuring parallax, rectifying tilt, plotting identified features, and reproducing image-intelligence reports.

In addition to the equipment just mentioned, the image interpreter also relies heavily on comparative imagery to detect small details on photography and various reference materials to catalog information.

STEREOSCOPY

Stereoscopy, the three-dimensional viewing of photographic images, plays a major role in identification. Many methods of determining height are based on the stereoscopic view. Comparative heights of shadowless features, so important in many phases of interpretation, are almost impossible to determine without stereoscopy.

Three Dimensional Effect

To understand how a three-dimensional effect is obtained with the aid of a stereoscope, you must first understand some basic aspects of human eyesight.

A person's normal binocular vision allows him or her to see objects in three dimensions. Binocular vision produces a sense of stereovision, or depth perception, involving three functions:

1. Focusing on the object;
2. Bringing together the two lines of sight on that object; and
3. Merging or fusing these two images into one, thereby giving the impression of solidity and depth.

The problem with single photos is that they show objects in only two dimensions, producing certain limitations on interpretation. It is difficult to positively identify objects, to judge heights, or to estimate the slope of terrain on a single, vertical aerial photograph. The solution to this problem is to apply some basic principles of stereoscopy. By doing so, you can obtain from two photographs an impression of three dimensions that is even greater than that of normal human vision. It is important to note that if you do not carefully adhere to these basic principles, you may experience fatigue and eyestrain and possibly reduce the effectiveness of the stereoscopy.

Basic Principles of Stereoscopy

If two photographs taken from slightly different angles are viewed with a lens type of stereoscope (figure 6-2), the two slightly different images, as seen by a normal person's eyes, are duplicated, resulting in stereovision.

The requirements for seeing correct stereo are as follows:

- Parallax—the slight difference in the two images being viewed.
 - The images must be at the same scale.
 - The images must not have moved between exposures.
- Proper alignment of the photographs (this is done in three steps).
 1. Place one photograph over the other with the matching detail superimposed. (See view A of figure 6-3.)
 2. Pull the photos apart (along the line of flight) until the parallax images (two slightly different views of the same image) are between 2.4 and 2.5 inches apart. (See view B of figure 6-3.)
 3. Place the stereoscope over the two photos so that one lens is over each of the parallax images. (See view C of figure 6-3.)

To help you determine what you can do to increase or decrease the accuracy and effectiveness of the illusion, we will now provide a more detailed discussion of the requirements for correct stereoscopic viewing.

PARALLAX.— If you stand a pencil on end and view it vertically with one eye at a time, you will observe two different views of the pencil. The views appear to shift slightly from one position to another as you switch eyes. This apparent displacement of an

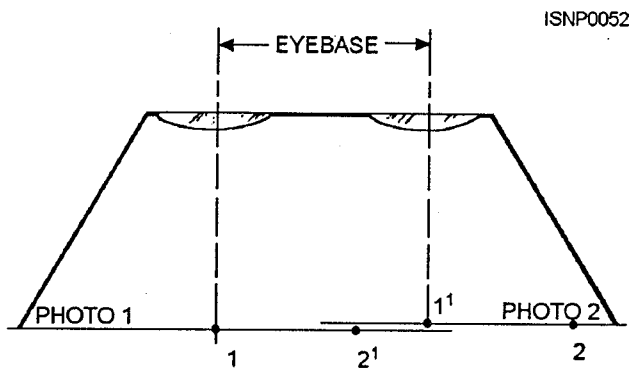
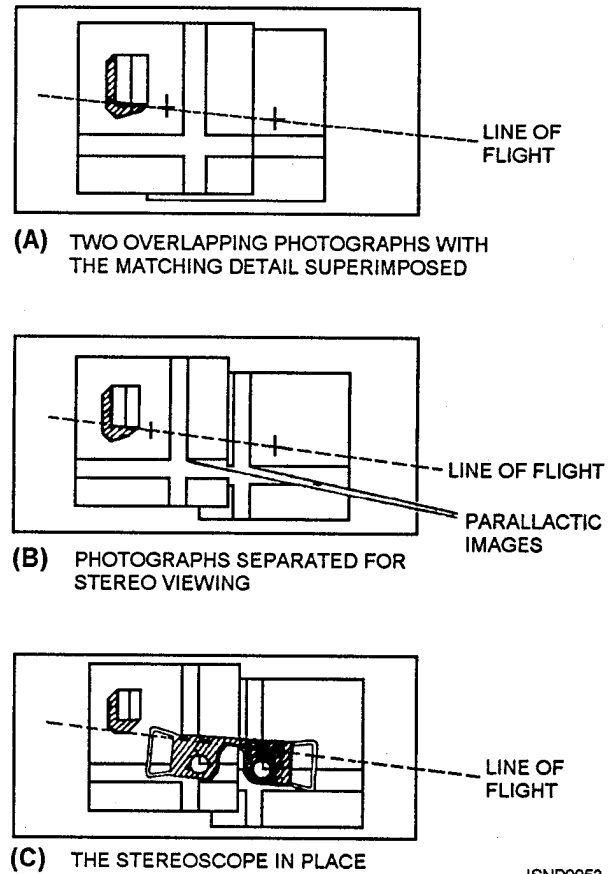

Figure 6-2.—Photo orientation under lens type of stereoscope.



ISNP0053

Figure 6-3.—Proper alignment of stereo imagery.

object viewed from two different places is known as *parallax*. When you look at any object, you actually see two different images, one with each eye, caused by two different lines of sight.

Parallax is a small difference between two images being viewed, but it is necessary to enable you to perceive the overall shape of an object. To make identifying an object easier, parallax can be increased by increasing the air-base distance. This is done by increasing the distance that the reconnaissance aircraft flies between two consecutive exposures. Parallax can also be increased by using every other exposure in a photo reconnaissance strip, if the overlap is great enough.

If an object (a motor vehicle for instance) is moving along the line of flight during the time the film is exposed, the parallax will either be increased or decreased for that object. The rest of the photograph, of course, will render a good stereo effect. If the object is moving in the same direction as the photo aircraft, the parallax will be decreased, and the stereoscopic effect will be correspondingly decreased. However, if the object is moving in a direction opposite to that of the

photo aircraft, the reverse will be true. In either case, a false parallax will result.

If the parallax is so exaggerated that the two images to be viewed are too unlike for the brain to accept as the same, a double image will result. This happens when a building with a tall spire on it (such as a church or a state capitol building) is photographed from a very low altitude.

PHOTO OVERLAP.— We have already discussed the correct way to align two overlapping prints for stereo viewing. Therefore, our discussion here will center on the mistakes that are frequently made in setting up photographs for viewing.

The most common mistake is lining up the images at right angles to the line of flight. It may sometimes be more convenient to do this (to get the correct distance between parallaxic images), but it greatly reduces the stereoscopic effect. Another disadvantage of this arrangement is that, when the two images are viewed, they may cause discomfort to the viewer. (See figure 6-4.)

Good stereo will result if the two overlapping photographs are simply pulled apart along the line of flight (the edge of one curled up if necessary) to get the correct distance between parallaxic images. (See figure 6-5.) The stereoscopic effect will not be affected

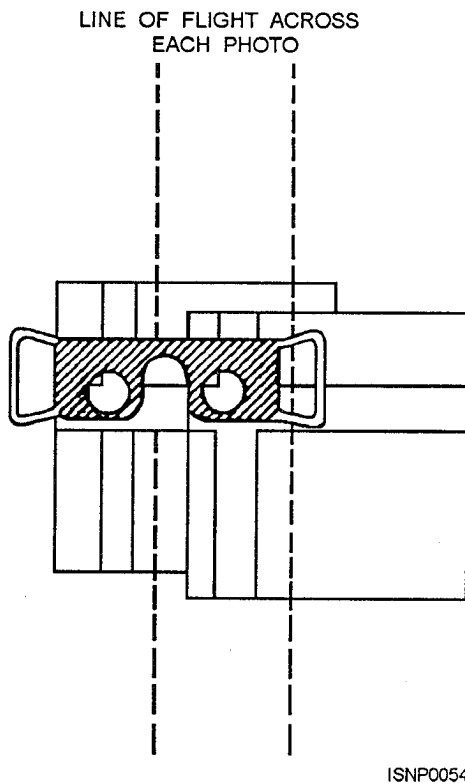

ISNP0054

Figure 6-4.—Incorrect alignment—not separated along the line of flight.

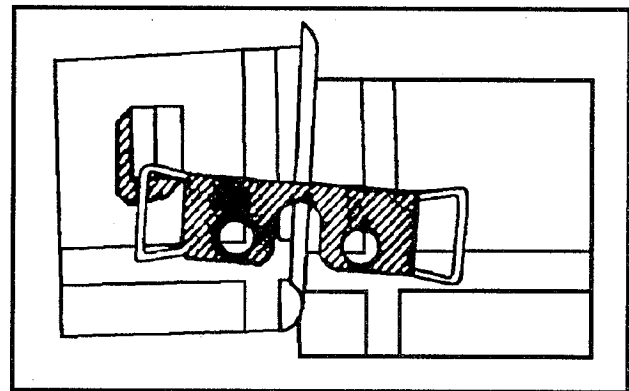

ISNP0055

Figure 6-5.—Correct alignment—along the line of flight.

if either the right or left photo is overlapped. The illusion of depth will be made even more realistic if the photographs are oriented so that the shadows on the photos fall away from the artificial light source being used. A desk lamp, in effect, replaces the sun that caused the object to cast a shadow.

Pseudo or “inverted” stereo occurs when the images are viewed with the photos in the reverse relationship to one another but still along the line of flight (the right photo on the left and vice versa). This can easily happen when stereo pairs are trimmed and permanently mounted for stereo viewing.

MAGNIFICATION

Magnification is the use of optical instruments to increase the size of the photographic image. Magnification helps the interpreter identify objects that may not be readily seen with the naked eye.

COMPARATIVE IMAGERY

“Comparative imagery” is the term applied to two or more sets of photography of a given area taken at different times or by different sensors. This procedure is one of the most useful tools of analysis available to the image interpreter. Comparative imagery enables the interpreter to detect otherwise unnoticed objects or activity, to verify identifications, and to establish approximate dates of activity. It is especially important that comparative imagery of enemy defenses be obtained frequently during their construction. Gun batteries and many other types of fixed installations can be readily detected and identified if their area is photographed while they are under construction. After they have been camouflaged, overgrown with vegetation, or otherwise disguised, such installations are extremely difficult to detect.

REFERENCE MATERIALS

Reference materials are extremely important to imagery interpreters. It would be impossible for an interpreter to mentally catalog the vast amount of information available for a given task. Examples of necessary reference materials are target folders, image interpretation keys, recognition manuals, maps, city plans, basic encyclopedias, industrial flow charts, and intelligence reports.

APPROACH TO INTERPRETATION

The first step in the interpretation process is to do a cursory search. A detailed study of the areas isolated in the cursory search is then made, followed by a report of the findings.

CURSORY SEARCH

The imagery interpreter usually discovers that aerial photography is full of surprises. It is a great temptation to study every detail of every frame for fear of missing something. Although a careful search often yields large amounts of information, much of this information is not pertinent to the subject and requires more time and effort than the interpreter can usually afford.

You can make more efficient use of your time by conducting a systematic, logical search. This way, you concentrate only on those areas that are likely to contain items of interest. You disregard large areas of the photograph that are not likely to contain the desired information. Obviously, this requires experience, since the interpreter must decide which areas rate the most consecrated study. The amount of time spent on concentrated study depends upon the area being studied and the type and nature of the work. Some types of interpretation require close study of the entire area photographed.

IDENTIFICATION AND ANALYSIS

You have probably determined by now that imagery interpretation is, in part, a process of elimination. Because the primary interest is in the military installation or object, the interpreter separates the natural features in the photo from the man-made and then eliminates the natural features. The man-made features are then broken down into two classes: military and nonmilitary. Eliminate the nonmilitary features, and military features (the primary goal) remain.

Distinguishing between natural and man-made objects is a simple matter. Contrast the wandering course of a river with the channeled bank of a canal. Nature works without pattern; man works in straight lines, sweeping curves, and angles.

Distinguishing between the two classes of man-made features or installations is much more involved. They must be studied to determine their use. For example, a permanent military installation has certain definite characteristics, such as rifle ranges, motor pools, parade grounds, gates, and fences, that readily distinguish it from a campus or a sparsely planned urban community. The process of interpretation also involves a certain *logical* evaluation of the area. For example, if the photography covers an enemy's front lines, a search is naturally made for front-tine defenses. Similarly, there would be no point in looking for a deep-draft ship in a shallow inland river.

Identifying objects in aerial photography by direct recognition is a fairly simple process. Either you, as the interpreter, know what the objects are because you have seen them before, or you do not know. Once you have recognized common elements of the landscape—roads, houses, railroads, streams—or had them pointed out to you, a glance is enough to identify similar features.

To identify objects you have not seen before, or to understand the meaning of objects once you have identified them, you should exploit the principle of convergence of evidence.

Many clues may exist as to the identity of an unknown object. None of the clues are infallible when considered individually; but if all or most of them point to the same conclusion, then that conclusion is probably correct.

Imagery interpretation, then, is actually an art of probabilities. Few things are perfectly certain in imagery interpretation. However, many interpretations are probable, so that when all visible evidence has been considered they may be safely regarded as correct. The difficult part of imagery interpretation consists in judgment of degrees of probability.

REPORTS OF FINDINGS

The system of imagery intelligence reporting has two primary purposes: (1) to exploit all photography taken for intelligence use to the fullest possible degree, and (2) to provide recipients the information they require, when they need it. To accomplish this, the interpreter uses a variety of specialized reporting

procedures and formats, which we will explain in detail in volume 2 of this training course.

BASIC PHOTOGRAPHY

As an Intelligence Specialist, you will not be expected to be a skilled photographer or photo processor. Nevertheless, it is important, in view of the technical knowledge being applied to photo interpretation and photo metrics, that you understand the basic principles of photography. The success of a reconnaissance mission may depend on your knowledge of the capabilities and limitations of optical reconnaissance as a source of intelligent.

BASIC CAMERA

There have been many variations of the camera. Some were rooms; other were compartments mounted on wheels or poles; and still others were portable boxes. When these devices finally became portable, they were known as PINHOLE CAMERAS.

All of these early cameras worked on the same principle: Light reflected from objects in front of the hole passed through the hole and projected an image of the objects against the opposite wall. The image had one peculiar characteristic—it was inverted and reversed in the same way as the images formed by modern lenses. The explanation of this characteristic is based upon the fact that light waves travel in straight lines. Figure 6-6 shows that light from a point at the bottom of an arrow travels in a straight line up through the small hole until it strikes the top of the opposite side of the box. Light from a point at the top of the arrow travels in a straight line down through the hole until it strikes the bottom of the opposite side of the box. Thus, the light reflects from the various points of an object and travels in straight lines through the hole to form an inverted, reversed image.

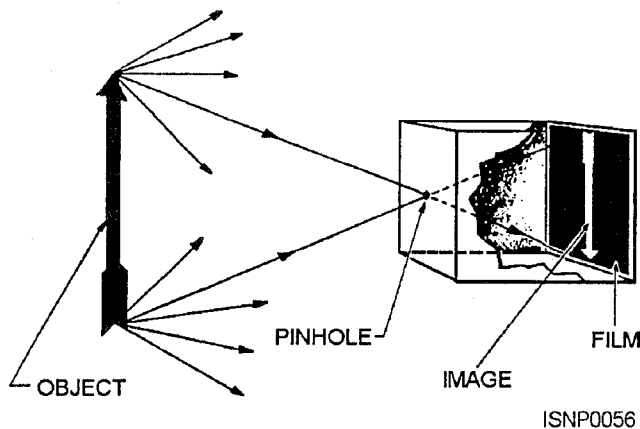

Figure 6-6.—Pinhole camera.

Various accessories and attachments for cameras have been devised, but a camera still requires these four basic parts:

- The dark box, or camera body, to exclude all unwanted light;
- The pinhole, or lens, and aperture to admit light rays to form the image;
- The screen, film, or other material to receive the image formed by the lens at the plane where the light rays come to a focus (the "focal plane"); and
- The shutter to control the amount of time that light is allowed to pass through the aperture.

PHOTOGRAPHIC TERMINOLOGY

Some of the basic terminology you can expect to see when dealing with photography is listed below:

- **Parallax error**— The difference in viewpoint from the viewfinder to the lens; common with range finder cameras and pocket cameras.
- **Focal length**— The distance from the optical center of the lens to the focal plane when the lens is focused at infinity.
- **Depth of field**— The zone of acceptable sharpness before and after the point of focus.
- **Angle of view (lens size)**— Normal (50-58mm), wide (24-45mm), narrow or telephoto (70mm or more).

LENS AND SHUTTER

A lens not only increases the brightness of the image but also improves its sharpness and permits control of the image size from specific distances. Sharpness is improved through the minimizing of diffraction, which occurs when the light strikes the edge of the small pinhole as it passes through. The image size at specific distances is controlled by the focal length. Brightness is controlled by the adjustable opening, the diaphragm.

Lens Speed

Another major characteristic of a lens, its speed, refers to the capability of the lens to gather the light that forms the image. This property, usually indicated by an f/number (discussed below), depends on the relationship of two factors: (1) the diameter of the

diaphragm opening and (2) the focal length of the lens. Other factors remaining constant, a larger opening admits more light, or is faster, and a larger focal length lens with the same diameter of opening decreases the light intensity, or is slower.

The relationship of distance to the intensity of light is mathematically expressed by the INVERSE SQUARE LAW. This law states that the intensity of light varies inversely with the square of the distance of the light from its source.

Combined in a formula, FL/D , the focal length and the diameter of the opening are expressed as a ratio, called the *f/number*. For example, if the focal length is 6 inches and the diameter is 1.5 inches, the *f/number* is 6/1.5, or *f/4*. Because the *f/number* is a ratio between the focal length and the diameter, all lenses with *f/numbers* of the same numerical value, regardless of focal length, give the same intensity of light on the focal plane, other factors remaining constant.

Using this formula as a basis and starting at 1, *f/numbers* have been chosen and put into a series in which each successive number indicates an opening that admits one-half as much light as the opening indicated by the previous *f/number*. These *f/numbers*, sometimes called FULL STOPS, are 1, 1.4, 2, 2.8, 4, 5.6, 8, 11, 16, 22, 32, 45, and 64.

The important thing to remember is that as the number increases, the amount of light admitted decreases and that the decrease is exactly one-half for each full stop. However, the *f/numbers* inscribed on the lens provide accurate numerical expressions of light transmission only when that particular lens is focused at infinity.

All good lenses have an adjustable diaphragm to control the amount of light transmitted by the lens. As the connecting lever is moved to change the diaphragm opening, it points to the corresponding *f/number* marked on the lens barrel. Unfortunately, the *f/numbers* marked on the lens barrel are not always full stops. Due to lens design, they may start at a half stop, a three-quarter stop, or merely an arbitrary point. In such cases, the next *f/number* is usually a full stop, but, then again, the one following it maybe a half stop.

To ensure accuracy in figuring the exposure from one *f/number* to the next, you should either memorize or calculate the full stops. One method of figuring full stops is to multiply each successive number (starting at 1) by the square root of 2 (1.4). Another method of comparing the relative value of *f/stops* is by using the

rule that the light admitted by any *f/stop* varies inversely as the square of the *f/stop*.

Shutter

The shutter, in conjunction with the diaphragm, forms the mechanism that controls exposure. The most important function of the shutter is to limit the time during which light is permitted to pass through the lens and act on the film. Another very important function is to limit the time the blades are open during exposure so the relative motion between a moving object and the camera does not cause the image to blur on the negative. These two functions of the shutter (limiting time of exposure and movement of the image) are entirely separate and distinct. However, the shutter speed, in combination with the *f/stop* necessary to obtain a correctly exposed negative is, in many cases, the same as that required to stop motion.

Shutter speeds are calibrated and measured in fractions of seconds, such as 1/10, 1/25, 1/50, 1/100, 1/250, 1/400. Frequently, on the more expensive shutters, a higher speed of 1/400 to 1/1000 second is available.

The two types of shutters commonly in use are the between-the-lens and focal plane types.

BETWEEN-THE-LENS.— The between-the-lens type of shutter uses a number of thin metal overlapping blades arranged perpendicular to the axis of the lens to prevent the passage of light through the lens to the film. The blades of this type of shutter are usually located between or near the lens elements as close as practical to the leaves of the diaphragm. It is common practice to enclose both the diaphragm and the shutter in the same housing. Through a system of gears, levers, cams, and springs, the shutter blades may be made to spring open and allow light to reach the film. Then, after a preset interval of time has elapsed, the blades return to the closed position, preventing light from reaching the film until the next exposure is made.

FOCAL PLANE SHUTTER.— The focal plane shutter consists essentially of a lightproof rubberized cloth curtain with rectangular openings or slits of different widths in it. The shutter is housed entirely within the camera body and is mounted on two rollers—one at the top and one at the bottom. As the curtain is moved from one roller to the other by spring tension, the selected opening passes in front of the film at the focal plane, permitting light to pass through the lens to the film.

After the opening has passed the film, movement of the curtain is stopped, and a lightproof section of the curtain prevents additional light from reaching the film. Where critical measurements of an image or subject in motion are required, the focal plane shutter is undesirable because of image distortion. At the instant the focal plane slot passes across the area of the film, the motion may cause the subject to be elongated or shortened, depending on the direction of the motion.

FOCAL LENGTH

When light is reflected from a point on an object, the light rays spread out like a pie wedge. If the object is close to the observer, or to the camera, the angle of spread is wide. As the distance between the object and the observer increases, the angle of spread decreases. Eventually, the distance between the object and the observer becomes so great that there appears to be no spread, suggesting that the light rays coming from the object are parallel. This distance is called *infinity*.

When a lens projects an image, the plane at which the image is sharply formed is called the *focal plane*.

Focal length refers to the distance from the optical center of the lens to the focal plane when the lens is focused on a point at infinity.

The manner in which the light rays are refracted determines the focal length. This refraction, in turn, depends upon the nature of the glass, the curvature of the lens surfaces, and the separation of the lens elements. The first two factors are fixed, but the third can be changed in some lenses. Therefore, the focal length remains constant for all lenses, except those few that have movable or removable elements.

The focal length of a camera lens is a determining factor in the coverage of that camera. The maximum coverage of a camera is expressed (in degrees) as the *angle of view*. The importance of the angle of view lies in its relationship to the area of ground covered.

When used with a negative of a given size and at a given altitude, a short focal length increases the angle of view and the area of the ground covered. A long focal length decreases the angle of view and the area of the ground covered at any given altitude. (See figure 6-7.)

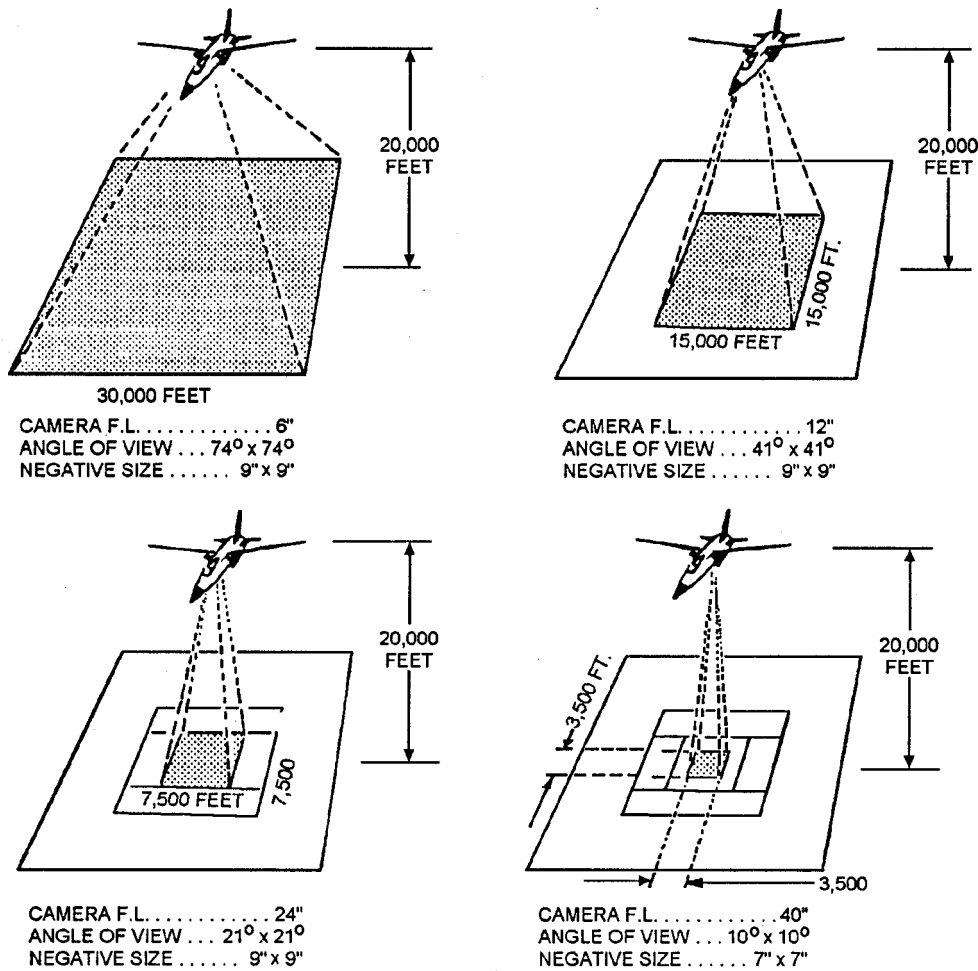

ISNP0057

Figure 6-7.—Comparison of angles of view.

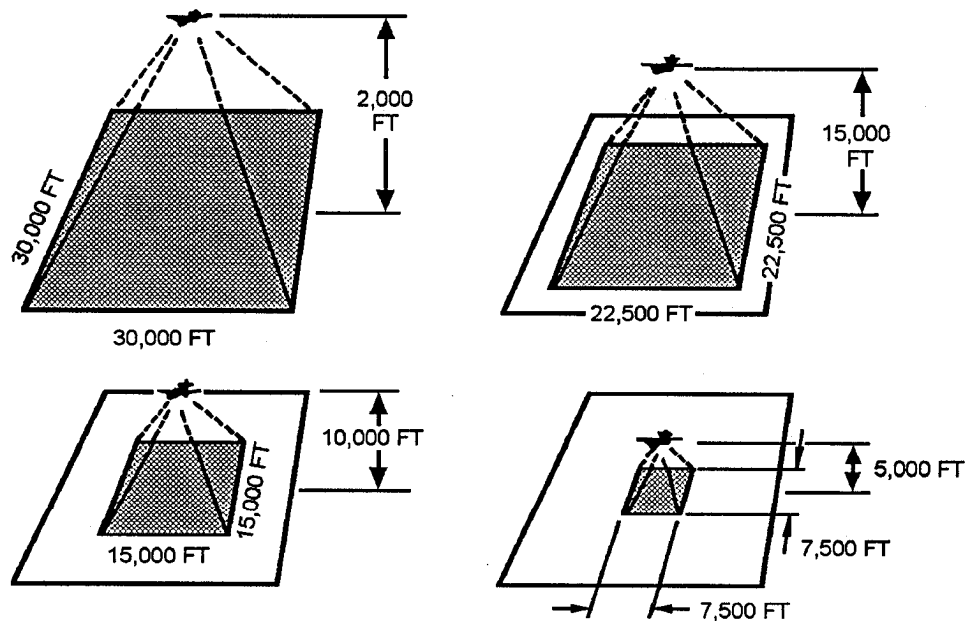

3-INCH FOCAL LENGTH

Figure 6-8.—Effect of altitude on scale and ground coverage.

The higher the altitude, the larger the area of ground covered by a camera of given angle of view. (See figure 6-8.)

The focal length of a camera, if the altitude remains constant, governs the size of the image. The longer the focal length, the larger the image. In other words, if two cameras of different focal lengths are used at the same distance from an object, the camera with the longer focal length gives a larger image size. (See figure 6-9.)

FILTERS

Human eyes and photographic film do not respond equally to all colors. The eyes sense the brightness or

dullness of colors. Film records colors as a range of grays, and these grays may not indicate how bright or dull these colors appear to the eye. When film is exposed by unfiltered light, bright yellow may reproduce as a dark gray, and a medium blue may be depicted as a very light gray in the print. The eyes are most sensitive to yellow and green, whereas all films are most sensitive to blue, violet, and ultraviolet. Consequently, the photographic reproduction may be unsatisfactory in some cases—blue skies too light, green grass too dark—and it is often necessary to use filters designed to render a scene or subject in tones that will appear natural to the eye.

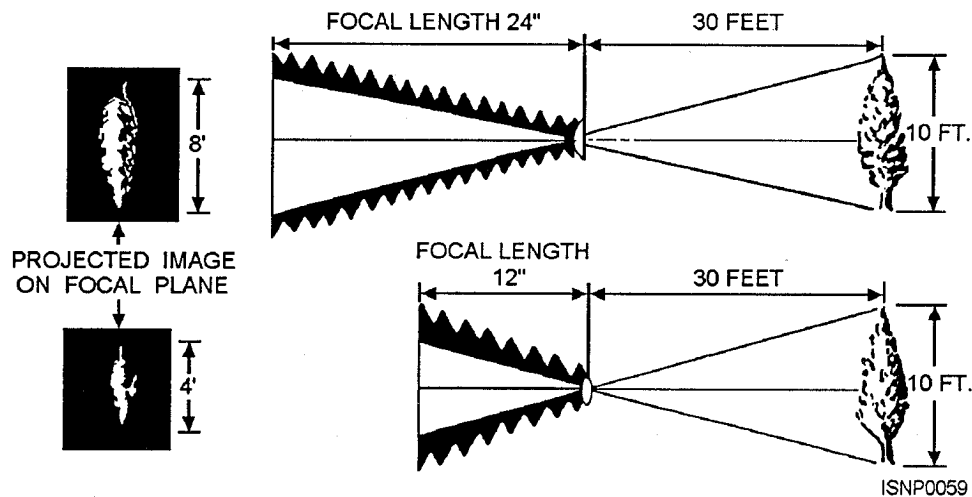

Figure 6-9.—Effect of focal length on image size.

When the term “filter” is used in photography, it refers to a transparent colored medium used to regulate either the color or intensity of the light used to expose the film. The color of the filter determines the color of the light that reaches the film. A neutral density or colorless filter regulates only the intensity of the light.

Filters vary considerably, since they are composed of transparent materials that maybe colored to a greater or lesser degree. Some are so nearly colorless that they escape casual notice; others are so deeply colored that they appear almost opaque. In all cases, however, the filter is used to modify the light that passes through the camera lens to the film.

In photography, a prime purpose of filters is to cut through haze. Haze should not be confused with mist or fog, which affects the film as white or gray areas, on which haze penetration filters have no effect. Atmospheric haze is always present, but it is especially noticeable in distant scenes and from high altitudes.

The greatest haze effect is the result of ultraviolet scattering, which the eyes cannot see. Violet and blue-violet light are also scattered, but to a lesser degree. In order to eliminate haze, a filter that absorbs the blue end of the spectrum should be used. A dark yellow filter produces better results than light yellow, and a red filter is better than dark yellow. However, the best results are obtained when infrared film is used with an infrared filter.

The form of filter most frequently used is a gelatin sheet cemented between two flat glass optical discs. Excellent filters of colored glass are also used and are considered more permanent than the gelatin type. However, they are more expensive, and their transmission characteristics are frequently less suitable.

SENSITIZED MATERIALS

The two essentials required to make a picture area camera and film, a sensitized material.

Remember, a camera is a light-tight box equipped with a lens, shutter, diaphragm, and a means of supporting the film.

A film consists of a light-sensitive emulsion coated on a base. The emulsion is a thin layer of gelatin containing many small particles called *silver halides*, which are sensitive to light. This emulsion makes it possible to record the image projected by the lens when the film is placed at the focal plane. The reaction of light on the silver halides is invisible until the emulsion is treated in a chemical solution called a *developer*. The developing solution changes the silver halides affected

by the light to metallic silver. The amount of silver halides affected, and subsequently changed to metallic silver, depends on the intensity and duration of the light striking the emulsion.

The photographic properties of an emulsion include color sensitivity, speed, contrast, latitude, granularity, and resolving power. The next paragraphs describe these properties and the effect each has on the negative or the print of a photograph.

Color Sensitivity

Because silver halides are sensitive to blue, violet, and ultraviolet light, all photographic emulsions are inherently sensitive to these colors. Sensitivity to other colors is obtained by the addition of various sensitizing dyes to the emulsion during manufacture. Progressive discoveries of new dyes have increased the sensitivity range of emulsions to cover the complete, visible spectrum and also the infrared rays.

Speed

Speed is a term used to express the sensitivity of an emulsion to light. Some emulsions are rated as “slow” because they require a relatively great amount of light to produce a satisfactory image, whereas other emulsions are rated as “fast” because of the relatively small amount of light necessary to produce a satisfactory image.

Contrast

The term “density,” as used in photography, refers to the amount of metallic silver in any area of an emulsion. The difference between the high and low densities of the various areas of the emulsion is called *contrast*. A bright area of a photographed subject reflects a great amount of light, causing a correspondingly heavy density in the negative, called a *highlight*. A dark area of a photographed subject reflects little light, resulting in a correspondingly thin density in the negative, called a *shadow*.

The brightness of the subject between these light and dark areas also registers in the negative as corresponding densities, called *halftones*. The difference in brightness, then, from highlights to shadows is called contrast. Normal contrast is represented by a full range of densities, including highlights, halftones, and shadows. High contrast does not have a full range of densities and consists mainly of highlights and shadows, with little or no intermediate graduation, and thus is undesirable for interpretation purposes. Low contrast has very little difference in densities.

Emulsions are manufactured with varying degrees of inherent contrast. High-contrast film is used to record a short range of tones, such as black and white, for copying line drawings. Medium- and low-contrast films are used to record a longer range of tones, such as might be found in a portrait or landscape. Therefore, the selection of the film should be governed by the contrast of the subject and the rendition desired.

Latitude

The ability of an emulsion to record a range of brightness values is called latitude. An emulsion capable of producing a long range of brightness values has a wide latitude. Conversely, an emulsion capable of producing only a short range of brightness values has but little latitude.

Granularity

A photographic emulsion contains microscopic particles, or grains, of silver halide. Because of certain processes in manufacture, these grains tend to clump together. This clumping characteristic, more prevalent in high-speed emulsions than in the slower emulsions, determines the inherent grain size in any film. Although inherent grain size can affect the image, proper processing techniques can prevent the silver grains from excessive clumping. When the grain becomes apparent in the image, it detracts from the clarity-and the print is said to be "grainy."

Resolving Power

The resolving power of an emulsion is a measure of its ability to reproduce fine detail. This measurement is stated as the number of lines per millimeter that the film is capable of recording clearly and distinctly. The resolving power of an emulsion is greatly affected by its grain size.

REPRODUCTION PROCEDURES

The reproduction of imagery depends on several factors. If you are on an aircraft carrier, the ship's photo lab has the capability to do virtually any type of reproduction. Conversely, if you are on a platform with reduced capability, the services will be reduced in kind. Large commands will have a total capability to reproduce imagery of all kinds. However, you must remember that resources are not limitless and the kinds of reproduction should be kept on an as-needed basis.

CONTACT PHOTO LAB

Each photo lab has its own accountability and control procedures. The lab will provide you with the

proper paperwork and identify who can or cannot approve imagery reproduction.

PROCESS FORMS

Once you have filled out the proper forms and gotten the necessary approval, the photo lab will process your work order. Receipt of the hard-copy prints or film negatives will depend on the urgency of your request. Processing time will also depend on the size of photo lab you are dealing with.

IMAGERY FILES AND SYSTEMS

With the advent of new technologies, imagery is no longer considered as "just" hard-copy prints of a given subject. With the introduction of the Fleet Imagery Support Terminal (FIST), the fleet was provided with the ability to transmit a digitized image of a hard-copy print between a Fleet Intelligence Center and a deployed unit.

Although the clarity of the image was degraded, it was able to give the group commander up-to-date information on a given area of interest. This earliest example of soft-copy imagery led to the development of new systems with expanded applications. These applications allow the user to become more adept at photo interpretation, target analysis, and mensuration.

SOFT-COPY SYSTEMS

Some of the soft-copy systems currently in use include the Joint Deployable Intelligence Support System (JDISS), Imagery Data Exploitation System II (INDEX II), Multisource Automatic Target Recognition Interactive Exploitation (MATRIX), Navy Tactical Command System-Afloat (NTCS-A) Imagery Exploitation Workstation (NIEWS), Photographic Image Editing System (PIES), and the Digital Imagery Workstation Suite Afloat (DIWSA). An overview of these systems is provided below:

- **JDISS**— This system (figure 6-10) provides a family of hardware and software capabilities, allowing users to connect and operate with the intelligence systems required to support forces in-garrison and deployed in peacetime, crises, and wartime. It provides the theater Joint Intelligence Centers (JICs) and Joint Task Force (JTF) commanders with a deployable rapid reaction system, which enables direct, on-demand query-response access to national, theater, and regional databases. The user has an integrated, interoperable tactical intelligence capability that includes host access, electronic

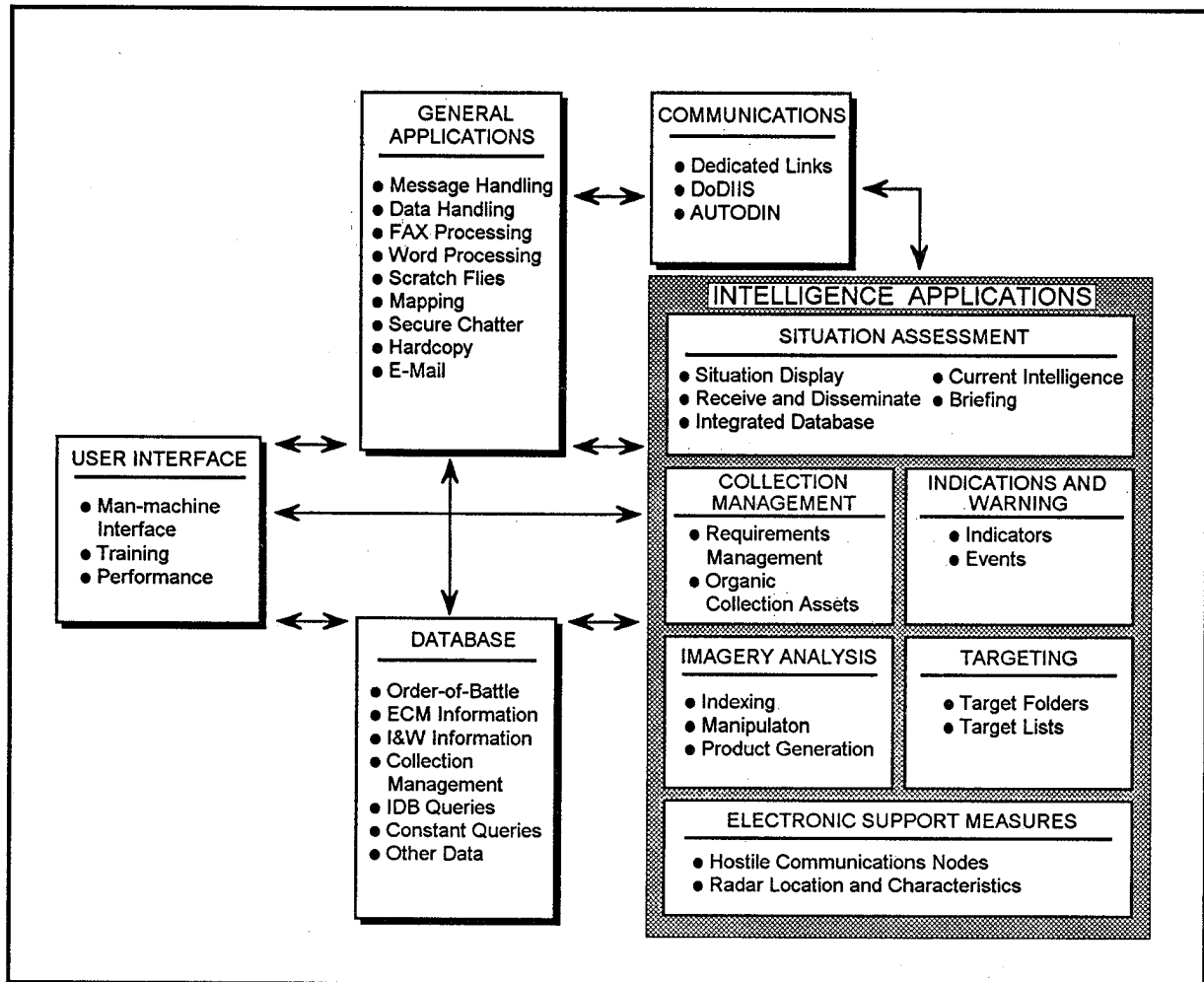

ISNP0060

Figure 6-10.—JDISS functional environment.

message handling, image processing, and map graphic capabilities.

- **IDEX II**— This system provides for the receipt, processing, storage, and use of digital imagery. It supports the production and dissemination of imagery reports and products, and stores the imagery on magnetic tape for future use. This system, along with MATRIX, is the mainstay of major shore imagery renters (JICs/JACs).
- **MATRIX**— This is low-cost software used to produce soft-copy imagery and imagery products. It allows imagery format conversions, image enhancement, mensuration, and manipulation (roam, zoom, and rotate).

Digital imagery produced by the various digital imagery systems, primarily JDISS, is stored in the Demand Driven Direct Digital Dissemination (5D) System. The 5D is composed of a collateral and

Sensitive Compartmented Information (SCI) product storage server designed to support theater and worldwide users. It allows analysts to input products (including target materials) from IDEX II, MATRIX, or other softcopy systems to a 5D-equipped terminal. The image is then available to the user as required.

- **NIIEWS**— This system provides for the manipulation and generation of digital imagery and imagery products. It also registers various data sources in support of intelligence needs. NIIEWS provides a soft-copy workstation capable of performing detailed mensuration on displayed image products; provides selective expansion of imagery from magnetic media (VLDS cassettes, 8mm tapes, etc.) and allows graphic overlay and annotation in the NTCS-A architecture. It also provides a transition of the precise mensuration capability from hard-copy film to the digital workstation, an image library

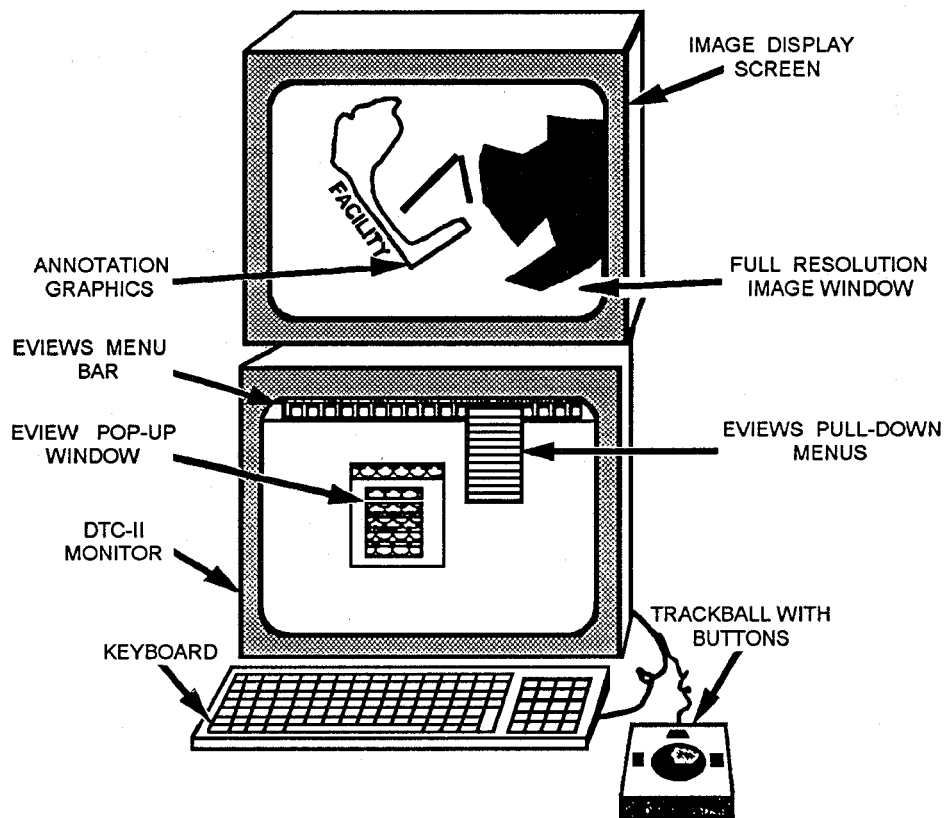

ISNP0061

Figure 6-11.—NIEWS configuration.

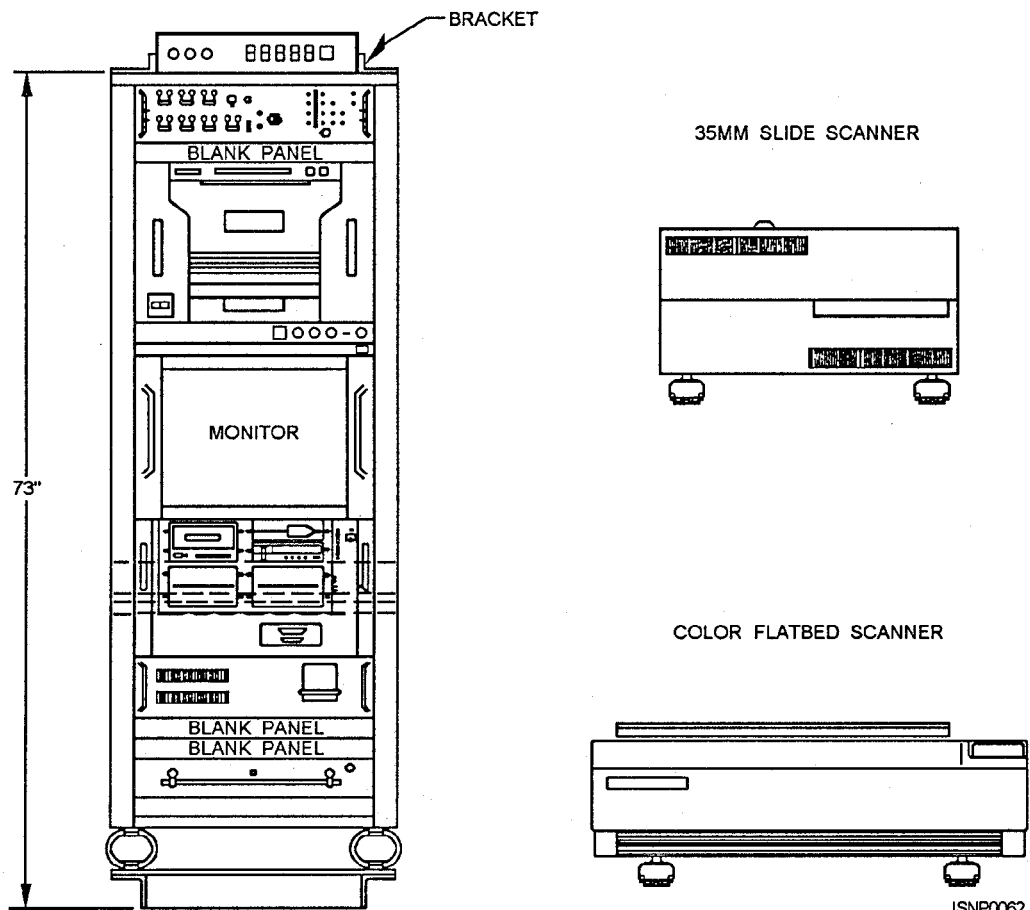

ISNP0062

Figure 6-12.—PIES configuration.

function for database image products and associated image support data, and preparation of registered image products for use in image exploitation and all-source analysis. See figure 6-11 for NIEWS configuration,

- **PIES**— This system is a shipboard-deployable photographic editing system with a collective capability to provide high-resolution image digitization, advanced image enhancement, digital image storage, and photographic quality hard-copy products. PIES provides the Navy with an electronic photo lab using the application of modern, automated digital imagery processing technology. This will help bring about the elimination of chemical storage of hazardous waste. See figure 6-12 for PIES configuration.
- **DIWSA**— This system is a component of the Theater Mission Planning Center (TMPC) and the Afloat Planning System (APS). DIWSA provides the Tomahawk Planning System Afloat (TPSA) planner with the ability to task production of such imagery products as Target Complex, Digital Scene Matching Area

Correlation (DSMAC), Vertical Update Point (VUP), Vertical Obstruction Data (VOD), Scene Area Suitability Assessment (SASA), and Terrain Profiles in support of Tomahawk Land Attack Missile (TLAM) missions.

The DIWSA allows for the registration of Recce images to the Point Positional Data Base (PPDB) reference images. This enables the analyst to obtain accurate latitude, longitude, and elevation measurements. The analyst is able to accomplish this because of DIWSA's ability to operate in both mono and stereo vision at a very-high-resolution value. DIWSA performs all the functions digitally that the Analytical Photogrammetric Positioning System (APPS) does on hard copy. DIWSA also contains a second software option known as the Joint Service Imagery Processing System-Navy (JSIPS-N). This added software capability is a digital light table and reporting system that is used to exploit tactical imagery and view/analyze national systems imagery. JSIPS-N interfaces with the NTCS-A, drawing off the message handler and historical database. See figure 6-13 for DIWSA configuration.

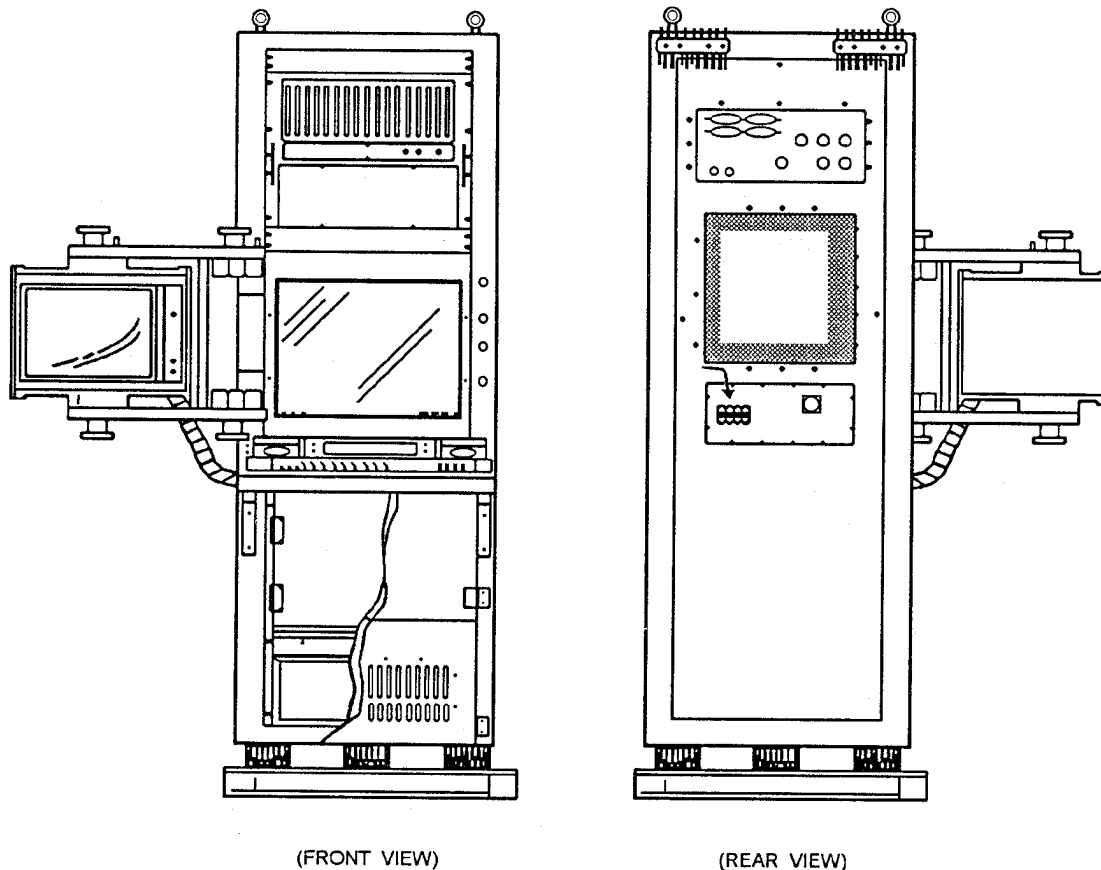

Figure 6-13.—DIWSA configuration.

ISNP0063

HARD-COPY IMAGERY

The term “hard-copy” imagery refers to the actual print from a photographic negative. The size of the print varies, depending on what the print will be used for. For example, ship-to-ship photographs are usually 8 x 10 inches; imagery that supports mission planning can go as high as 20 x 24 inches or larger. Here is one factor to remember: As the prints get larger, the resolution and detail of the image get worse.

RETRIEVAL METHODS

Methods to retrieve imagery vary, depending on whether you are working with hard- or soft-copy imagery. Usually hard-copy prints, or “flats” as they are referred to, are stored and cataloged by area or Basic Encyclopedia (BE) number. Soft-copy imagery is stored on tape or within a database. Retrieval of the data file depends on the software being used. Consult your software user’s guide and command SOP for the proper guidance.

INTELLIGENCE PHOTOGRAPHY

Throughout the history of the intelligence community, photography has played a vital role in assessing an enemy’s capabilities and strategy. Knowledge of an adversary provides the operational commander with both the historical, and, in most cases,

up-to-date intelligence to support any action deemed necessary by higher authority. The potential value of intelligence photography is not only important to the operational commander, but also to the scientific and technical intelligence community as well. Once you consider all the factors of analysis, you can make an assessment on the capabilities and usage of an item, facility, or installation being photographed.

In any surveillance action, it is desirable to augment the single photo with stereo views. To fully understand how intelligence photography supports the intelligence collection process, you need to know the types of photography and collection strategies currently in use. Some of these are identified in the following section.

STILL PHOTOGRAPHY

Having different views of a target is very important when you are conducting imagery analysis. Equally important is the scale of the image. Large-scale telephoto views of a given subject, such as a radar mast or gun system, will provide excellent detail when you are attempting to ascertain the role of a system. The small-scale view will provide an overall view of the platform.

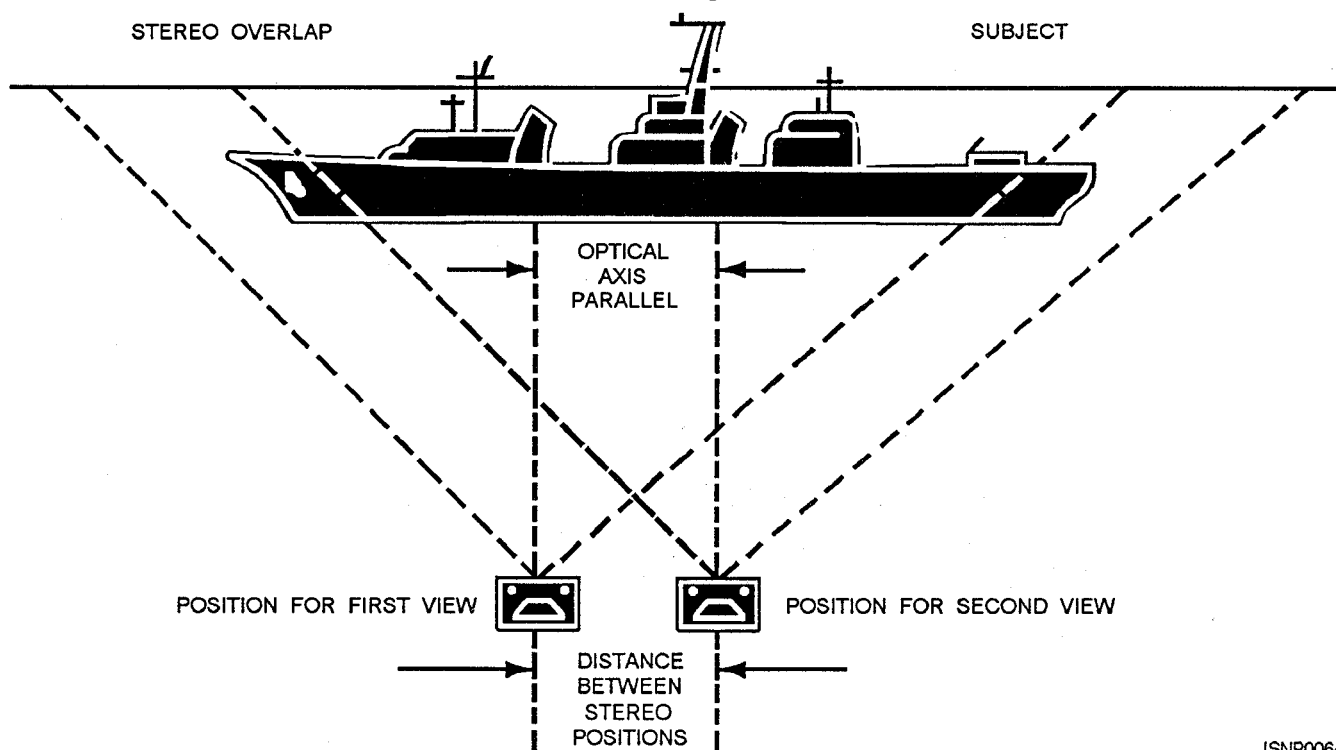

Figure 6-14.—Two successive exposures, which provide a stereo pair.

ISNP0064

Stereo

Stereo imagery will give you a three-dimensional image, allowing certain aspects of the image to stand out. To accomplish this, take the photographs as the subject or target moves laterally, parallel to the focal plane of the camera (see figure 6-14).

Eight-Point Rig

The standard eight-point rig (figure 6-15) provides excellent coverage for targets of interest. For correct eight-point coverage, the entire ship must be within the field of view for each of eight predetermined angles of view.

COLLECTION

There are stated general and specific requirements for the collection of imagery. This section discusses general requirements for certain targets. Refer to the PHOTINT guidance sheets in the *Fleet Intelligence Collection Manual (FICM) (U)*, ONI-2600Z-001-YR, for specific requirements.

TYPES OF COVERAGE

There are several types of target coverage for photograph collection. The type of coverage required depends strictly on what medium or platform you are working with. There are advantages and disadvantages to each type; your job is to identify both the advantages and disadvantages and then to decide which type will best accomplish the collection mission. You must use all the resources available to you to complete the collection. Some potential types of collection are mentioned below.

Motion Picture or Video

Motion picture or video allows the interpreter to record all the actions of the ship or target and the activities of those personnel who are performing their normal duties. Video is particularly important if there is an "Incident at Sea." The actions and reactions of all concerned should be recorded.

Ship-to-Ship

Ship-to-ship photography allows the photographer to maintain contact with the target for long periods of time. There is also a stable environment available. This will assure that photographs are taken with the proper amount of care, and that distortion is at a minimum.

Helicopter

Helicopters allow the photographer the opportunity to get closer to the target. They are very maneuverable and will usually allow for the completion of the eight-point rig. However, turbulence and camera movement are two drawbacks to using helicopters.

AERIAL PHOTOGRAPHY

Aerial photography is a very important element of the total intelligence effort. In any conflict or war, there is a need for combat intelligence gathered by aerial reconnaissance photography. The most important use of aerial photography is to collect information on otherwise inaccessible areas. This information then becomes a permanent record that later may be systematically interpreted and evaluated. Over the years, the Navy has continued to improve its aerial photographic capabilities.

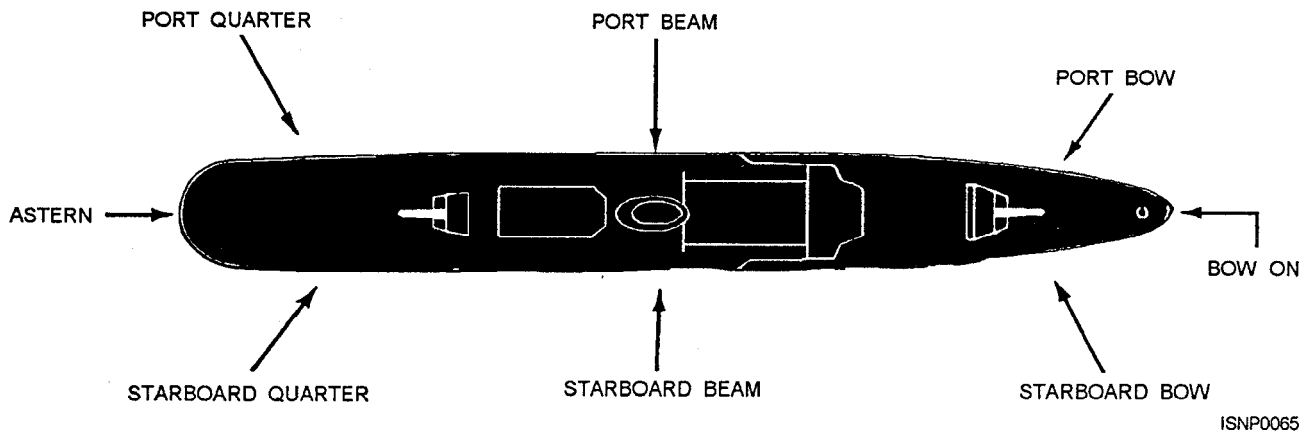

Figure 6-15.—Standard eight-point rig.

In the Navy, the two principal uses of aerial photography are to gain information about an enemy and to provide photographs for mapping and charting. The gaining of information about an enemy through aerial photography is referred to as “reconnaissance” or “intelligence” photography. These photographs are usually shot from high-performance jet aircraft using pilot-controlled camera systems. However, all reconnaissance photographs are not taken with sophisticated, automatic camera systems from high-performance jet aircraft. At times, hand-held cameras are used for reconnaissance photography. Most aerial photographs today are made by photo-configured aircraft, such as the F-14 Tomcat with the Tactical Air Reconnaissance Pod System (TARPS). Aerial photographs for preparing or revising maps or charts are taken specifically for that purpose.

Although aerial photography is an excellent source of intelligence information, it does have certain limitations. Intelligence personnel must be familiar with these limitations in order to exploit the advantages. For instance, aerial photography is limited by weather; light conditions; availability of aircraft, film, and cameras; and enemy opposition. Therefore, you must take these characteristics into consideration when viewing the film.

Concepts of modern photo reconnaissance require more than a simple camera or two. New designs in optical surveillance call for a system of complex camera installations with automatic controls to minimize the amount of attention required by the reconnaissance pilot. Therefore, if you acquaint yourself with aerial camera characteristics, aerial camera identification, types of aerial cameras, aerial photographic installations, uses of aerial cameras, special photo-reconnaissance uses of cameras, and aircraft capabilities, you will be able to become a highly skilled photo interpreter.

CAMERA TYPES

The principle of the aerial camera is the same as that of the common box camera. However, the mechanical and electrical features of the aerial camera make it much more complex. The aerial camera consists basically of a light-free box that supports a lens, diaphragm, and shutter at one end and a light-sensitive film at the opposite end. Like the box camera, the aerial camera uses a fixed-focus lens because images of all objects photographed from aerospace are shot at distances so great they may be considered to be at infinity.

Aerial cameras derive their names primarily from the way the film passes through the systems, by their position in the aircraft, and how they are used. The three common categories of these cameras are framing, continuous strip, and special format.

Framing Camera

The framing camera holds the film flat and stationary during the exposure. The name of the camera is derived from the resulting “frame,” or black border, around the exposure. By comparison, the continuous strip camera uses the passage of the film across a slit aperture to control the exposure and to compensate for the forward speed of the aircraft. The border still appears, but the duration of the operating time of the camera is extended.

In a typical framing camera (figure 6- 16), a platen holds the film in place. The platen in an ordinary camera is generally a spring-tension device to counter the natural curl of the film. In aerial cameras, the most common platen is vacuum operated. The framing camera takes a series of exposures that have common ground from exposure to exposure (overlap) for stereo viewing. The camera must recycle (move the film between exposures) for each shot. With large-film formats, the recycling time may be too slow for low-altitude, fast-moving aircraft.

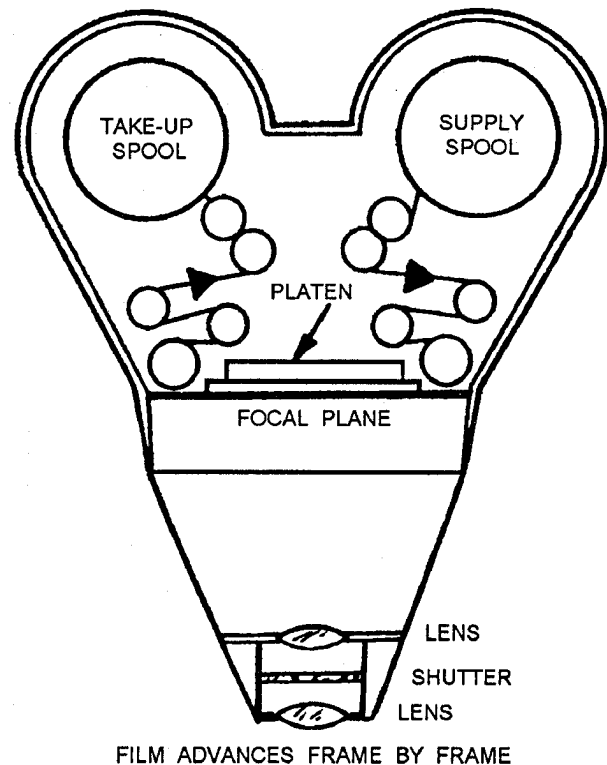

ISNP0066

Figure 6-16.—Framing camera.

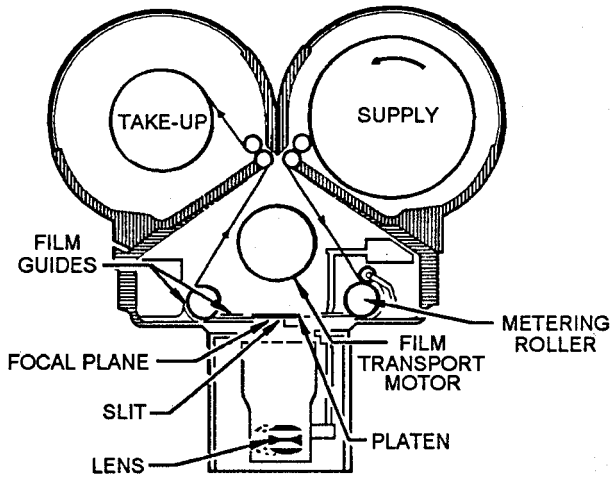

FILM IN CONTINUOUS MOTION

ISNP0067

Figure 6-17.—Continuous strip camera.

When a framing camera is used with the film parallel to the ground, it is called a **vertical** camera. If the film is not parallel to the ground, it is called an **oblique** camera. The use of two or more framing cameras mounted close together is called a **fan configuration**. We will discuss these cameras later, under camera installations.

Continuous Strip Camera

The continuous strip camera (figure 6-17) was developed for low-altitude, high-speed missions. The film passes continuously in the same direction as the

flight of the aircraft. A slit aperture to stop the movement of the ground imagery controls the exposure. The same principle is used to stop the image of a rapidly moving object by "panning" a camera in the same direction as the object is moving; for example, photographing auto races. Another example of a continuous strip camera is the stereo strip camera. Dual lenses expose a continuous roll of film to present stereo imagery side by side.

Special Format Camera

The special format camera, generally called the "panoramic," or "pan," camera, uses principles of both the framing and continuous strip cameras. As in the framing camera, the film in the panoramic camera moves during exposure. And, as in the continuous strip camera the pan camera is capable of horizon-to-horizon coverage. The special format pan camera (figure 6-18) is capable of scanning a wide area of terrain with no loss of optical quality. The panoramic camera effectively accomplishes exceptionally wide coverage with no loss of optical quality.

Panoramic cameras represent a development for taking aerial photographs. Horizon-to-horizon coverage was formerly available only through the use of several cameras. Now the panoramic camera provides the horizon-to-horizon coverage through the use of a seating principle that incorporates a rotating lens, mirror, or prism.

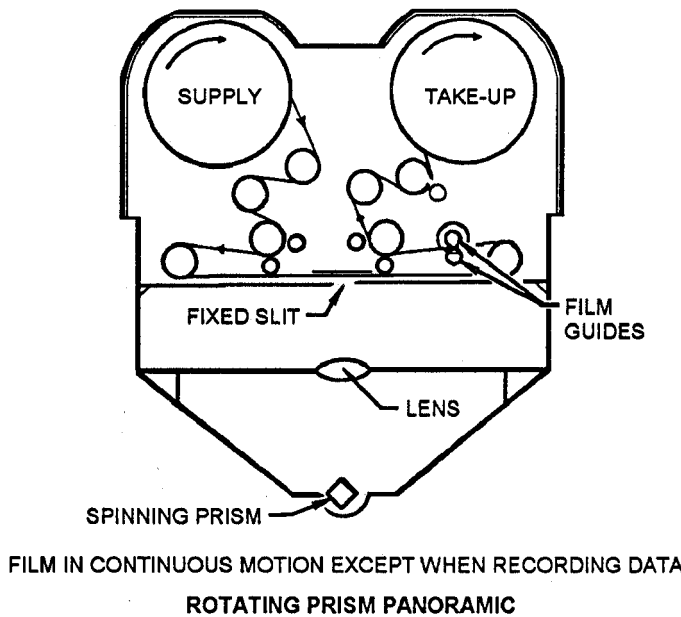

FILM IN CONTINUOUS MOTION EXCEPT WHEN RECORDING DATA

ROTATING PRISM PANORAMIC

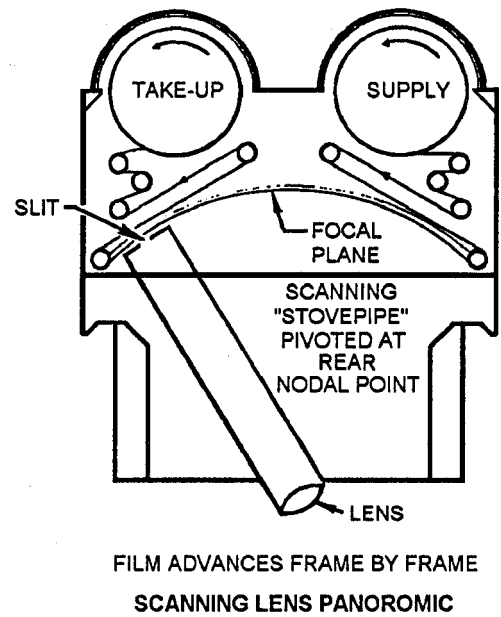

FILM ADVANCES FRAME BY FRAME

SCANNING LENS PANORAMIC

ISNP0068

Figure 6-18.—Special format panoramic cameras.

Other examples of aerial cameras include the typical movie camera and gun camera as sensors of imagery. They only supplement the basic aerial cameras and, because of their presentation and scale of imagery, are not beneficial reconnaissance tools. Still, other types of cameras are used to record and document imagery of radar screen presentations and to take periscope photography. We will discuss these cameras later in this chapter.

TYPES OF AERIAL PHOTOGRAPHY

Cameras installed in aircraft are all used for one specific purpose—to visually record information that can be studied and evaluated at a later time and in great detail.

Because of variations in the types of information required, the cameras used to record this information are of many different designs. When a camera is used to collect any of the broad categories of information, the characteristics of weight, size, speed, film size, focal length, cycling rate, angular field of view, and image motion compensation (IMC) all have to be taken into consideration.

In this section, we will describe reconnaissance, mapping, and maritime surveillance photography, radarscope photography, infrared reconnaissance systems, forward-looking infrared photography, and laser photography. These are some of the categories of uses of aerial cameras and sensors required to collect and record information.

Reconnaissance Photography

Reconnaissance is described as a mission undertaken to obtain, by visual observation or other detection methods, information about the activities and resources of an enemy or potential enemy. The mission also may be made to secure data concerning the meteorological, hydrographic, or geographic characteristics of a particular area.

Reconnaissance photography can thus be described as photographs taken primarily to obtain information on the results of bombing or on enemy movements, concentrations, activities, and forces.

As you can see from the definitions of reconnaissance and reconnaissance photography, any type of sensor or camera maybe used to obtain the best results.

Mapping and Charting Photography

Mapping and charting photography is used specifically for preparing or revising maps or charts.

Mapping and charting photography is very exacting. The cameras used are therefore precision instruments. They are calibrated to determine the exact focal length, the lens distortion in the focal plane, and the location of the principal point relative to the fiducial marks.

The aircraft used to conduct mapping and charting photography should be a large, stable type. Precise navigation is required. It is extremely important that the pilot fly the exact preplotted flight lines to photograph the desired area and maintain the proper exposure interval to provide the correct forward overlay between exposures.

Maritime Surveillance Photography

In view of the increased threat of a large and growing foreign submarine and surface ship force, the Navy has an urgent need for continuous photographic coverage of these units to aid in keeping abreast of advancements in foreign technology. Additionally, surveillance of merchant shipping and fishing vessel activity is needed to aid in determining the pattern and significance of foreign merchant shipping operations and to provide information on the activities and movements of foreign vessels.

Maritime surveillance data gathering for intelligence purposes is assisted by photography. That is, pictures provide permanent remarks of such quality that detailed interpretation of the collected data can be made. Since cameras can instantly record full details of any target, photographs should be made for all maritime targets worthy of observation. Air reconnaissance photographs of surface and subsurface targets, made from fixed-wing aircraft and helicopters, add greatly to the complete intelligence data on the maritime shipping of actual or potential enemies.

The best photographic composition of a ship is not always obtained by shooting horizontal views just because the ship is large. In maritime surveillance photography, it is important that the target be recorded as large as possible on the film. This can be done by using correct photographic composition, appropriate field of view, and proper rigging patterns. A rigging pattern is a specific set of views from which the photographs are taken. The primary rigging patterns are discussed below.

RIGGING PATTERNS.— There are four basic rigging patterns for maritime surveillance photography: the *special interest rig*, the *quick rig*, the *normal rig*, and the *standard rig*. Proper rigging of the target provides maximum intelligence data from the resulting photography.

To better understand the purpose of each rig, you must know what each view of the target (or point) the rig is designed to achieve. The bow quarter view is useful in determining forward deck cargo-handling equipment, electronic arrays, and vessel identification. The beam view provides the target length, in addition to stack and antenna height. The stern quarter and stern views are used for determining cargo and electronic arrays, for determining full deck cargo, and for measurement purposes.

Special Interest Rig.— The special interest rig is required when a target is to be photographed for the first time or when specific areas of interest on a particular vessel need photographing. Before this type of mission is flown, a special briefing is conducted to establish which specific rigs should be flown to satisfy mission requirements.

Quick Rig.— The quick rig is designed to be used for a routine photographic documentation of a contact (vessel) observed while on patrol. The photographs consist of a bow, beam, and stern quarter view of the vessel. For most aircraft used in maritime surveillance photography, the best approach for rigging is from the bow of the target,

Normal Rig.— The normal rig, commonly referred to as the *five-point rig*, consists of bow quarter, beam, stem quarter, stern, and vertical views. This rig is normally used to provide a detailed representation of a vessel.

Standard Rig.— The standard, or eight-point, rig is required when enemy or potential enemy vessels are photographed. The eight-point rig provides complete coverage of all areas of interest. Additionally, a vertical exposure should be obtained in all cases where direct overflights are not prohibited by operational restrictions.

Additional photographs are also required of all non-U. S., unidentified warships; any vessel having extensive electronic arrays; or vessels that are acting suspiciously. These photographs should include the following views:

- Close-up views of electronic equipment or other items considered to be of special interest;

- Views from varying altitudes and angles including, when practical, vertical or plan views; and
- Stereo pairs and close-up and normal-distance views.

ITEMS OF INTEREST.— Normally, two photographs of merchant vessels, trawlers, and targets of opportunity are sufficient, with one exposure taken broad on the beam at masthead height and the other from a suitable altitude to reveal deck cargo. When merchant vessels are photographed, items of specific interest are electronic gear, weapons on board, deck cargo, type and count of equipment being hauled, nationality of the ship, and the size and shape of crates on deck.

When foreign warships are photographed, items of specific interest are electronic gear, weapons on board, old side numbers that may show under new numbers, size and shape of odd-looking gear, position and description of a submarine's conning tower and sail section, or any significant information that might help to classify and identify the vessel.

Additional information about acquiring and reporting of shipping surveillance is available in the *Fleet Intelligence Collection Manual (FICM) (U)*, ONI-2600Z-001-YR.

Radarscope Photography

Radarscope photography is a film record of the activity on the radar screen (scope). Radar normally is a phenomenon involving aimed radiation through space and its consequent reflection. Therefore, effective radarscope reconnaissance is possible with radar equipment operating from aircraft, from ships, from submarines, and on the ground as long as the objective area is not masked by a mass that cannot be penetrated by the radar signal. The radarscope image makes possible effective all-weather operations.

Radarscope photographic reconnaissance provides the following information:

- Information on prestrike, strike, and post-strike intelligence;
- Information to assist all-weather offensive operations; and
- Information used in constructing new maps or correcting existing ones.

An automatic 35mm recording camera that will permit simultaneous visual viewing of the screen is generally used for taking radarscope photographs. The camera shutter is electronically timed to remain open during one movement of the radar sweep across the scope. Several exposure-interval selections are provided, including every scan or every 2nd, 4th, or 12th scan. The image on radarscope photography includes a counter, a clock, and a data card.

The advantages of radarscope photography include the following:

- **Day or night capability**— The quality of radarscope photography is not affected by the time of day.
- **Weather capability**— Radar energy can penetrate most types of weather. Only severe thunderstorms or heavily water-saturated clouds interfere with the radarscope portrayal.
- **Area coverage**— Radarscope coverage can exceed a 200-nautical-mile radius around the aircraft.
- **Camouflage penetration**— Radar energy penetrates conventional camouflage materials, such as netting and paint.

The disadvantages of radarscope photography include the following:

- **Poor resolution**— An object is portrayed according to its degree of radar reflectivity and resolution capability. Detailed identification is impossible.
- **Susceptibility to electronic attack (EA)**— EA can be directed against a radar system and may make the radarscope portrayal unreadable or cause misidentification of returns.

Infrared (IR) Reconnaissance Systems

Many details of operational IR sensors are classified. This section provides unclassified information pertinent to current infrared-sensing techniques.

The most significant difference between a conventional camera system and an IR system is the source of the electromagnetic radiation they record. Visible light waves imaged by cameras are the result of reflections from the target of a light source independent of the target, such as the sun or a flash cartridge. On the other hand, IR waves result either from energy within

the target itself or from energy that the target absorbs and subsequently releases or emits. Thus, IR radiation can be recorded at night when the target releases, as heat, the energy absorbed from the sun during the day. Daytime IR images, however, can be both reflected and emitted radiant energy.

Most modern IR sensors have the following components:

- Optics;
- Detector and cooler;
- Data processing unit; and
- Optical recording.

When either photographic film or magnetic video tape is used as the recording medium for IR imagery, the tonal variations in the image are represented in shades of gray. After a roll of film has been exposed and developed, a light table maybe used to examine the imagery in negative format. Scene elements of high radiance are dark areas on the negative, and scene elements of low radiance are translucent, or light, areas.

The film negatives may be used to make contact prints, or positive format hard copy, for imagery interpretation. In this case, areas of high radiance in the scene are light; areas of low radiance are dark. Many IR imaging systems that use video tape as a recording medium provide the user with the option of reversing circuit polarity to record either a positive or negative image.

Forward-Looking Infrared (FLIR)

In a combat situation, the imagery obtained from linescan recording systems is often too late for tactical reaction. In response to this situation, specifications were set up to provide a real-time readout capability for aircrews. Many real-time readout linescan systems were tried. However, the imagery presented on the cathode-ray tube (CRT) was still only that which the aircraft had just flown over, and no immediate reaction was possible. This brought about the integration of a forward-looking infrared, or FLIR, system with an active weapons system, thus providing immediate reaction to the information obtained.

The FLIR is a passive detection system used primarily for recognition and identification of surface ships, submarines, and submarine wakes. Secondary functions include target verification, weapon delivery observation, and navigation landmark identification.

A FLIR system takes IR radiation emitted from the surface and converts it into an electrical signal. This signal is then formed into a visual signal on a real-time display system using a CRT. The presentation appears very similar to the images seen on TV, but this is where the similarity ends. The picture on the CRT is showing the intensity of IR radiation and, thus, must be interpreted in the same manner as exposed film from an IR detector system.

The variations of gray shades seen on the CRT are called the dynamic range of the system. With good dynamic range on the display, small targets are much easier to distinguish, thus giving the overall presentation a much more pleasant appearance.

Laser

The term *laser* is an acronym for Light Amplification by Stimulated Emission of Radiation. The laser produces a light beam that does not diffuse as the light from an ordinary light source does. Several different lasers have been developed, including crystal, semiconductor, gas, organic, and chemical types. Laser devices have been produced in many shapes and sizes, large and small. Continual research is being conducted on laser applications.

Laser sensors used aboard reconnaissance aircraft are electro-optical recording sensors, not light-recording cameras. Visible frequency energy is beamed to the ground and reflected back to the apparatus. The reflected optical energy is sent to a photomultiplier and converted into electronic impulses. These electronic impulses can then be amplified, recorded as a video signal, or handled with other electronic techniques and devices.

The striking quality of laser photography is the absence of ground shadows. The interpreter is thus deprived of data used to distinguish between objects and to measure their heights. However, the no-shadow feature may work advantageously in under-foliage detection since small targets obscured in the shadow on conventional photography may be exposed by the laser beam. There is also a subtle recording of tonal changes, not only in black and white but also in the use of discrimination techniques, in a variety of color combinations.

SPECIAL PHOTO-RECONNAISSANCE USE OF CAMERAS

As an Intelligence Specialist, you will be required to exploit every available means to gather meaningful

and timely data about an adversary. You must be familiar with the special photo-reconnaissance techniques, such as night photography, ground photography, and periscope photography in order to exploit its advantages. By acquainting yourself with the capabilities of these camera systems, you will be better able to plan reconnaissance missions and evaluate their results.

NIGHT PHOTOGRAPHY

As you might expect, the principal difference between night and day aerial reconnaissance photography is that night photography depends on artificial illumination. The requirements for night photography are determined primarily by intelligence considerations—to obtain information on enemy night activities. Aircraft engaged in night photographic reconnaissance use photoflash cartridges or electronic flasher units to provide the required illumination.

Uses of Night Photography

Night photography makes continuous intelligent surveillance possible. Some of its uses are as follows:

- Obtaining limited damage assessment;
- Detecting decoys and camouflage;
- Estimating enemy plans by detecting night operations and buildups of troops and materials;
- Locating and identifying active anti-aircraft defenses; and
- Identifying types and capabilities of enemy submarines and merchant shipping.

Night photography, although often difficult to interpret and usually inferior to that taken in daylight, is of vital importance because it provides information that may be unobtainable at any other time.

Types of Night Photography

There are two types of night photography: instantaneous (photoflash) exposures and time exposures.

In instantaneous exposures, the shutter is open, and the film moves at image motion compensation (IMC) speed. Photoflash cartridges are ejected from the aircraft at desired intervals. As the cartridges explode, they provide the necessary illumination and trigger a photoelectric cell that closes the shutter and recycles the camera.

The exposures are made by simply leaving the shutter open with the film moving past the aperture at IMC speed. The purpose of this type of exposure is to record light traces over a wide area. A photoflash cartridge may be released from the plane at some point to provide illumination for ground detail. Continuous lights and fires appear as streaks across the photographs.

AERIAL CAMERA IDENTIFICATION

A system of joint military type designators has been developed to provide identification for all aerial cameras. For identification by the equipment type designation system, cameras are categorized as picture-taking equipment. This category is assigned a distinctive letter designation to indicate a major item, accessory, attachment, or component, and a mission letter to show the mission or function of each item. Each two-letter combination has a model number assigned in numerical sequence and, when required, a suffix letter assigned in alphabetical sequence to show various changes to the basic model. The category and mission letters for aerial cameras are as follows:

CATEGORY LETTER:

- K-Camera;
- L-Accessories, attachments, or components for cameras.

MISSION LETTER:

- A-Reconnaissance;
- B-Strike recording;
- C-Aerial mapping;
- D-Scope recording;
- E-Still picture (not otherwise classified);
- F-Motion picture (not otherwise classified);
- G-Special purpose (including instrumentation);
- M-Miscellaneous;
- S-Set or system.

EXAMPLES:

- (KS-87B):
Camera set, model 87, strike recording mission
- (KA-99A):
Camera reconnaissance, model 99, reconnaissance mission

For a complete listing of camera types and their characteristics, refer to the *Reconnaissance Reference Manual*, NAVAIR 10-1-789.

AIRCRAFT RECONNAISSANCE CAPABILITIES

An aerial photographic system may simply be the same hand-held camera you use on the ground, or it may be a complex, electronically pilot-controlled system, such as the Tactical Airborne Reconnaissance Pod System (TARPS) configured F-14 Tomcat. In the following discussion, we give only a very brief overview of the different Navy aircraft, including the F-14 Tomcat, S-3 Viking, and the P-3 Orion, with their reconnaissance capabilities and associated cameras.

F-14 TOMCAT

With the development of the F-14 Tomcat equipped with the TARPS, the Navy continues to improve its photographic reconnaissance capabilities.

The TARPS pod, containing two optical cameras and an infrared detection system, is attached to a specially configured F-14 called the *Peeping Tom*. Although retaining all the air superiority characteristics of the non-TARPS F-14, the Peeping Tom gives tactical commanders a wide range of sensor capabilities, including day/night, high/low altitude coverage as well as high-speed penetration and medium-range standoff reconnaissance.

The camera systems are comparatively simple to operate, and the pod itself is equally easy to service and maintain. Current CV assets can provide complete support for the system, from film processing to final intelligence analysis and dissemination. Finally, because the Peeping Tom is still fully fighter capable, those aircrews that are identified with the program have the distinction of being both fighter and reconnaissance qualified, thus assuring themselves an even greater role in the fleet.

The pod is designed to be aerodynamically and structurally suitable for supersonic flight. It is nonjettisonable and is attached directly to the starboard-underside of the fuselage at weapons station number 5. Operation of the reconnaissance system in the pod is controlled by the Naval Flight Officer/Radar Intercept Officer (NFO/RIO) (back-seater) using the Computer Processor Signal/Sensor (CPS). In addition, the pilot is provided with a camera on/off capability via the bomb button on the control stick.

Target location and camera control information is given to the crew by the Tactical Information Display (TID) and the Heads Up Display (HUD). The TARPS-equipped Tomcats retain a significant offensive capability, even when they are carrying out a photographic role. The aircraft can be returned to full combat configuration in a few minutes by removing the external TARPS. See figure 6-19.

Each squadron having TARPS aircraft is assigned enlisted Intelligence Specialists who work in a ground support role at the squadron level along with the Intelligence Specialists operating in the Aircraft Carrier Intelligence Center (CVIC).

TARPS contains the following reconnaissance sensor and auxiliary equipment:

- Pod;
- Environmental Control System (ECS);
- KS-87B Camera;
- KA-99A Camera;

NOTE: When the KA-99A low-altitude panoramic camera is mounted in bay 2 of the TARPS pod, about 4 inches port and 3 inches starboard in the field of view (FOV) are lost due to the imaging of the external fuel pods mounted under the wing of the F-14

Tomcat. This results in a loss of about 7 inches in film format from a total of 28.3 inches of the format size.

- KS-153 Camera;

NOTE: This camera is fitted in station 2 in place of the KA-99 when mission requirements dictate. The KS-153 camera is a 24-inch sensor that uses three vertical/oblique 9 x 9-inch shots to simulate pan.

- AN/AAD-5 Infrared Line Scan (IRLS);
- Maintenance Control Panel;
- Sensor Control/Data Display Set (SC/DDS); and
- Reconnaissance Control Processor Unit (RCPU).

Miscellaneous hardware includes the following equipment:

- KS-87B camera-mount;
- Vacuum pump; and
- Winch (2).

S-3A VIKING

The S-3A is a twin-engine turbofan aircraft designed specifically for carrier and antisubmarine

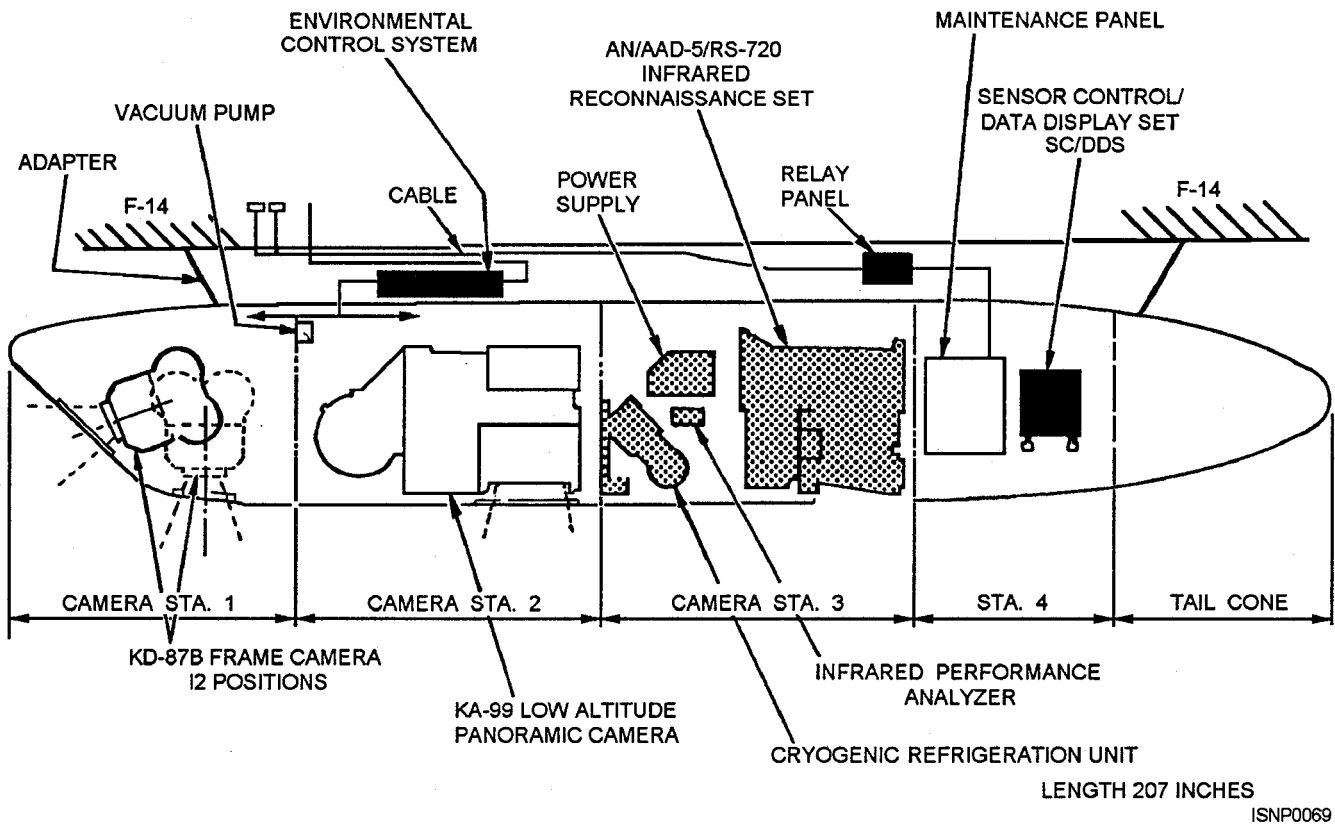

Figure 6-19.—F-14 Tactical Airborne Reconnaissance Pod System.

warfare (ASW) missions. Its prime missions are task force and convoy screening, antisubmarine barrier surveillance, contact investigation, and surface surveillance with attack capability for all missions. The primary reconnaissance system on the S-3A that you will be interested in is the FLIR system.

P-3C ORION

The P-3C is a computerized, long-range, turboprop, maritime patrol aircraft whose primary mission is ASW. Its secondary mission is surface surveillance and reconnaissance of combatant and merchant ships.

The P-3C uses several acoustic and nonacoustic electronic sensors in ASW. These include MAD, ES, Inverse Synthetic Aperture Radar (ISAR), Infrared Detection System (IRDS), and visual sightings.

ISAR is a processing system that generates true, recognizable, two-dimensional images of any selected ship target. It relies on the motion of the target ship to generate a two-dimensional image. Processing short-aperture times, ISAR generates continuous images that correspond in real time to target motion.

IRDS is a passive search and localization sensor that operates on the same principles as FLIR. IRDS photography has gained importance in the aviation intelligence community as a viable intelligence gathering source.

Photo reconnaissance equipment includes the 35mm hand-held, the Agiflite 70mm, and Sony still video cameras. The still video equipment is especially useful in that you have the capability to transfer images to floppy discs and immediately review the image. Images can then be digitally transferred to other still video capable units in a matter of minutes vice the hours required for hard-copy film.

FUTURE DEVELOPMENTS

Currently being considered by the Department of Defense (DOD) is the Advanced Tactical Aerial Reconnaissance System (ATARS). With the F/A-18 as the host platform, the ATARS will be composed of a suite of sensors that will give the F/A-18 a real- and near-real-time aerial reconnaissance capability. In other words, ATARS will have the ability to record imagery on magnetic tape for later transmission to the ground, or imagery can be data linked as it is being collected.

The ATARS suite will not only alter forever the way imagery is processed and exploited, but it will also

change the functions of the reconnaissance aircrew. In the past, imagery obtained by the aircrew was not viewed until minutes, maybe hours, after it was collected and the crew was back on the ground. With ATARS, the aircrew will be able to view imagery in the cockpit and make real-time decisions about the results of the mission. ATARS will be capable of manual or automatic operation.

ATARS is composed of the following equipment components:

- A Low-Altitude Electro-Optical (LAEO) sensor;
- A Medium-Altitude Electro-Optical (MAEO) sensor;
- An Infrared Line Scanner (IRLS);
- Two Digital Tape Recorders (DTRs);
- A Reconnaissance Management Set (RMS); and
- A Data Link (D/L).

If the cockpit workload and threat permit, video may be viewed in real-time to ensure that the sensors are working properly or to verify that the particular target was not obstructed by weather. Conversely, if the video cannot be viewed in real-time, the magnetic tapes may be rewound at a later time and any or all targets may be reviewed. To simplify the review portion of the mission, you can recall any portion of the video by event, time, or latitude/longitude.

The edit feature of ATARS allows the aircrew to pick portions of imagery that have the highest priority and mark them for transmission to Joint Services Imagery Processing Stations (JSIPS). By editing the imagery, the aircrew can adjust the amount of time required to data link its imagery and free them to return to base or perform other missions while airborne. Since ATARS has the ability to record in excess of 3 hours of imagery, a good portion of the imagery will often be forwarded to the JSIPS for detailed exploitation. The review and edit modes of ATARS are particularly suited to a crewed aircraft, such as the F/A-18.

TITLING OF AERIAL PHOTOGRAPHY AND AIRBORNE SENSOR IMAGERY

This section presents the DOD standardized procedures and specifications for the titling of aerial photography, electronic sensor imagery, and related

information as set forth in the *Aerial Photography and Airborne Sensor Imagery (Forwarding, Titling, and Plotting)*, DIAM 55-5. Plotting and forwarding procedures can vary somewhat, depending on the operational situation; however, you should always refer to DIAM 55-5 for the proper guidance. These procedures apply to all DOD activities engaged in the acquisition of aerial photography or other airborne sensor imagery.

Titling of aerial photography and airborne sensor imagery is designed to provide unique, human-readable, identification to each frame or segment of exposed film. Proper titling is one of the most important phases in aerial photography and airborne sensor imagery. The imagery is practically useless without this pertinent data.

Titling elements as specified in DIAM 55-5 apply to the original negatives and normally are applied immediately after the film development process. This will ensure that all film copies contain the same identification as the original negatives.

When you title aerial photography, position the titling information along the running edge of the film out of the imagery area, when possible. Apply titling on either the film base or film emulsion side, whichever allows the titled data to read correctly when the photographic image is geographically oriented to a base map. Present all titling data in numerals and uppercase letters, and restrict the data to two lines unless you are operating under a waiver for more lines. Case-by-case waivers may be applied for by contacting the Defense Intelligence Agency.

The leader and trailer of the roll of aerial film must be a minimum of 10 feet long. Both are made of a single length of preprinted or clear film of the same width and thickness as the original negative and are attached (taped) to the ends of the roll of film. The information on the leader and trailer should be applied with markers containing a permanent type of ink. The ink must not transfer when the film is rolled up and must be reproducible during photographic printing.

Materials used for titling on film must be resistant to deterioration and removal through normal usage and cleaning. No grease pencil or other marking media that could transfer or otherwise affect the cleanliness of the film may be used for applying any markings to any part of the leader, trailer, or original negative material. No identification data should be placed on a gummed label or other similar opaque media since these will not reproduce during printing. In addition, no marks or

labels of any kind that could damage the value for other users of the film should be used to identify areas of interest along the length of the original negative.

REQUESTING IMAGERY

At some point in your career as an IS, you may need to request imagery augmentation for your ship or command. This section presents basic information and references available to help you in this process. In some cases, the process may be simple and require only a message; more complex requests will require more work on your part and a thorough knowledge of not only your local chain of command but your national-level commanders as well. Consult the latest version of the *Air Reconnaissance Manual (U)*, NWP 25-3 (NWP 3-55.11), and the *Imagery Requirements (U)* manual, DIAM 58-5, for specific guidance in requesting imagery.

AUTHORIZATION

Before requesting any imagery, you must notify your appropriate chain of command to get the proper authorization to task reconnaissance assets. The reason for this should be obvious; your chain of command must be aware of what their platforms are being tasked against. They must also be able to track each asset to guard against duplicate tasking and to ensure each request is justified. In times of conflict, everyone in the theater will believe his or her request is the most important. During these times, it will take a calmer head to ensure that each asset is being used to its best advantage and that it isn't being used frivolously. This requirement is especially important today, when we are working more and more in a joint environment, not only with our own military forces, but with our allies as well.

PROCEDURES

For requesting F-14 TARPS, P-3C, or other generic fleet assets, refer to NWP 25-3 (NWP 3-55.11) for message preparation formats and the appropriate chain of command through which to submit the request. When requesting coverage from satellite or other special airborne collection platforms, make your requests to the Defense Intelligence Agency according to the instructions in DIAM 58-5, chapters 4 and 5.

GROUND PHOTOGRAPHY

Any photograph that is taken at or near ground level with a hand-held or tripod-mounted camera, the optical

axis of which is pointed horizontal or nearly horizontal, is considered to be a terrestrial, or ground, photograph. Because of its unique orientation, the terrestrial photograph requires special metrical analysis to determine ground dimensions.

Under normal conditions, a 35mm camera of high quality is recommended for the collection of terrestrial intelligence photography. The film available for this type of camera allows a wide range of emulsion speeds and resolving powers. The size of the camera is usually small, often permitting concealment. Film cassettes are also small, allowing a quantity of film to be carried. Accessories and lenses enable the camera to satisfy a number of requirements.

Other cameras may be used in special situations. Twin lens and single lens reflex cameras allow ground glass focusing that is useful in making closeups of still objects. Stereo systems also may be used, such as stereo cameras, cameras with stereo attachments, two cameras fired simultaneously, and one camera exposing from a moving base or capturing moving objects with two exposures. Ultra-miniature cameras using 16mm and smaller film may be used when needed.

PERISCOPE PHOTOGRAPHY

There are two types of periscope photography: reconnaissance and combat.

Reconnaissance Periscope Photography

Submarine reconnaissance photography is taken through the periscope lens system of a submarine when the periscope is above water in a position of observation. This procedure has the following advantages:

- Permits the collection of information concerning otherwise inaccessible areas;
- Verifies information taken from aerial photographs and other sources;
- Reveals details not normally obtained from aerial views; and
- Presents a view of coastal areas, harbors, and shipping which is more directly applicable to amphibious operations than that obtained from aerial photography.

Combat Periscope Photography

Photographs of enemy shipping taken before, during, or after an attack are of great value. They furnish excellent identification of shipping and establish or verify mission accomplishments.

BASIC IMAGERY RECOGNITION

Military image interpreters may be attached to any intelligence organization. No matter where the assignment is, the image interpreter remains primarily engaged in producing intelligence information by analyzing images on film. Under optimum conditions, image interpretation can produce highly accurate and detailed military information. The following section provides guidance on basic recognition characteristics as they apply to interpreting naval forces, aircraft, and missile systems.

NAVAL FORCES

Interpreting naval forces is one of the many tasks that you will perform. You will be required not only to identify many classes of ships and submarines but also to attempt to describe their weapons and radar systems. The multitude of information available on naval forces is too great to be included in any one text. For this reason, you must consult the many reference publications available on this subject. The following publications are a sample of the sources available:

- *Naval ships Characteristics—USSR, Combatants*, DST-1210H-049-YR;
- *Naval Ships Characteristics—USSR, Auxiliaries*, DST-1210H-050-YR;
- *Characteristics and Capabilities of U.S. Navy Combatant Ships*, NWP 1-11.1;
- *Soviet Naval Debriefing Guide*, DIAM 57-25-170;
- *Recognition Guide*, DIAM 57-25-XXX-YR (Series);
- *JIIKS, Submarines*, DIAM 57-7, Volume XIII;
- *JIIKS, Major Surface Combatants*, DIAM 57-7, Volume XIV;
- *Fact Book, Communist World Forces*, DST-2660Z-13-YR;
- *Jane's Fighting Ships* (an excellent unclassified reference book for all navies).

Additionally, military capabilities studies contain naval forces information on most countries that have naval ships. These studies incorporate old naval, air, and ground forces intelligence studies, and contain information about organization, capabilities, personnel, mobilization, and future developments. They also contain maps of naval shore establishments.

Volume 2 of this manual will provide further information on tactics and operations.

Combatants

The purpose of combatants, or warships, is to engage enemy ships in naval warfare. Combatants are assigned various missions, depending primarily on armament, and secondarily on characteristics, such as size, speed, and maneuverability.

AIRCRAFT CARRIERS.— Aircraft carriers (CVs) (see figure 6-20) are the largest warships afloat and are the major offensive surface ships in any battle group (BG). Aircraft are their chief weapons, and missions are determined by the type of aircraft carried. The high freeboard and expansive, uncluttered flight deck give the aircraft carrier a distinctive appearance. On many carriers, the superstructure, or “island,” which is offset to the starboard side of the flight deck, is the only prominent feature on the flight deck. Flexibility is provided because the CV carries the various types of aircraft needed in current tactical situations. In addition to a full squadron of ASW aircraft, two or three squadrons of attack aircraft are also carried.

Helicopter carriers (CVH, LPH, LHA), such as the former Soviet-built KIEV-class CVHG, have a mission to support ASW and amphibious operations. They usually carry only helicopters and/or VTOL aircraft and

normally do not have arresting gear or catapults. Helicopter carriers resemble conventional carriers, but are smaller in length and displacement.

CRUISERS.— The general mission of cruisers is to operate offensively against air and surface threats. They operate in conjunction with strike, antisubmarine, or amphibious forces. Cruisers usually measure from about 550 to 700 feet in length and displace from 6,000 to 20,000 tons.

The previous classifications of cruisers as heavy (CA) or light (CL) referred to the armament. With the advent of missiles, the CA and CL designators have lost their significance for the major navies of the world. The missile-age designation of guided-missile cruiser (CG) is now more commonly used.

Although CGs have the same general mission as their predecessors, they serve primarily as a control center and the Anti-Air Warfare Coordinator (AAWC) for the battle group. In this role, they support airborne aircraft in their missions and also defend a large geographic area from attack. Equipped with highly sophisticated radar and missile systems, most notably the *Ticonderoga*-class CGs, modern guided-missile cruisers are smaller and more compact than the older gun cruisers.

DESTROYERS.— Destroyers (DDs) are versatile, multipurpose warships of moderate size (3,000 to 8,000 tons, about 400 feet in length) and are equipped to perform diverse missions, such as ASUW, ASW, and AAW. Destroyers typically have two large stacks with considerable rake, light masts, superimposed gun mounts forward, ASW gear aft, and torpedo tubes topside.

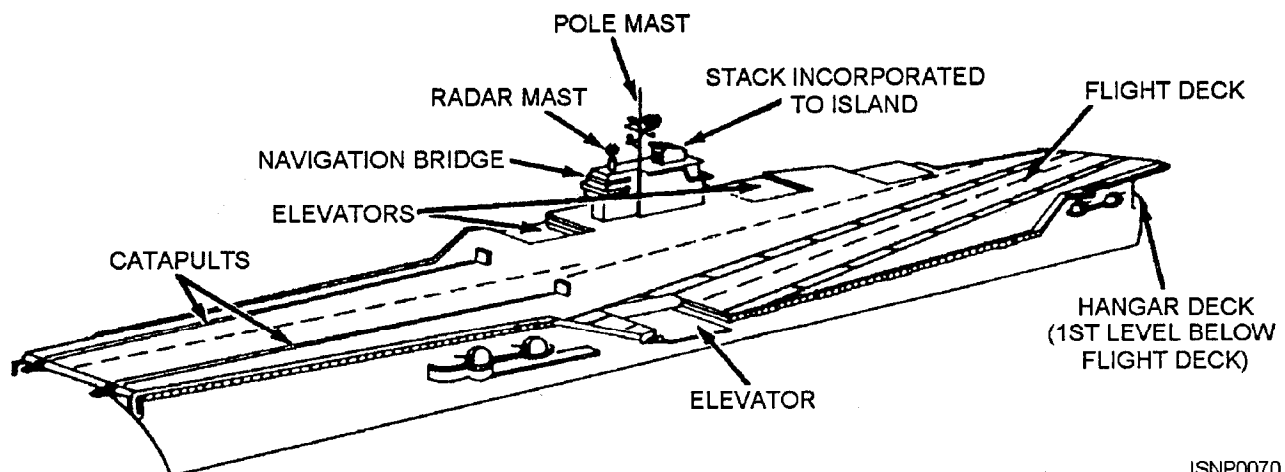

ISNP0070

Figure 6-20.—Aircraft carrier.

Guided-missile destroyers (DDGs) vary widely in armament layout and are difficult to typify, with the exception of the newly commissioned *Arleigh Burke* DDGs, which are comparable in weapons and electronics to the Aegis-equipped *Ticonderoga*-class CGs.

FRIGATES/CORVETTES.— Frigates (FFs) and corvettes (FFLs) fall into the general category of smaller major combatants, whose offensive weapons and sensors are used for a particular warfare role, such as screening support forces and convoys. Frigates (some of which were formerly designated as destroyer escorts [DEs]) range in length from 300 to 400 feet and displace from 1,500 to 4,000 tons. They usually have only one main gun mount forward (up to 5'); the aft armament often consists of ASW and/or AAW weaponry. A helicopter pad is present in the stern area.

Corvettes displace from 900 to 1,500 tons and, therefore, lack the sustained endurance of frigates, although they are capable of open-ocean operation, usually closer to littoral areas. Their armament is similar to that of a frigate, but they seldom have a helicopter pad aft.

MINOR COMBATANTS.— There are numerous types of minor combatants, such as minesweepers and patrol boats. Many countries that either do not require or cannot afford larger ships use these smaller combatants for river and coastal defense patrols.

Many of the newer patrol boats are armed with missiles, which increases their firepower, and some are equipped with hydrofoils, or air cushions, which greatly increase their speed and maneuverability.

Amphibious Ships

Amphibious ships are designed to move combat personnel and equipment ashore. With the exception of shore bombardment, the armament of amphibious ships is usually used for defensive purposes only.

Some large amphibious assault ships (LPDs and LSDs) (see figure 6-21) have weaponry forward and a flight deck aft, thus appearing similar to helicopter carriers. However, they differ in several ways: fewer helicopter landing pads (1 to 4 versus 5 to 15), a fold-down ramp gate at the stern (replacing the transom), and the presence topside of cranes and other machinery. Figure 6-22 shows a Commonwealth of Independent States (CIS) IVAN ROGOV-class LPD.

Medium and small amphibious ships are usually characterized by an aft superstructure and a long, open deck area forward.

Auxiliary Ships

There are many types of auxiliary ships that perform a variety of duties. All auxiliary ship designations begin with the letter A. For instance: AGI—intelligence collection ship, AK—cargo ship, and AOR—replenishment oiler.

Auxiliary ships are usually lightly armed for self-defense and rely mainly on combatants for protection. They are constructed in various sizes and configurations unique to their special roles. Many auxiliary ships, especially those used for replenishment and repairs, have cranes and booms on deck that are used to transfer equipment, supplies, and fuel to the fleet.

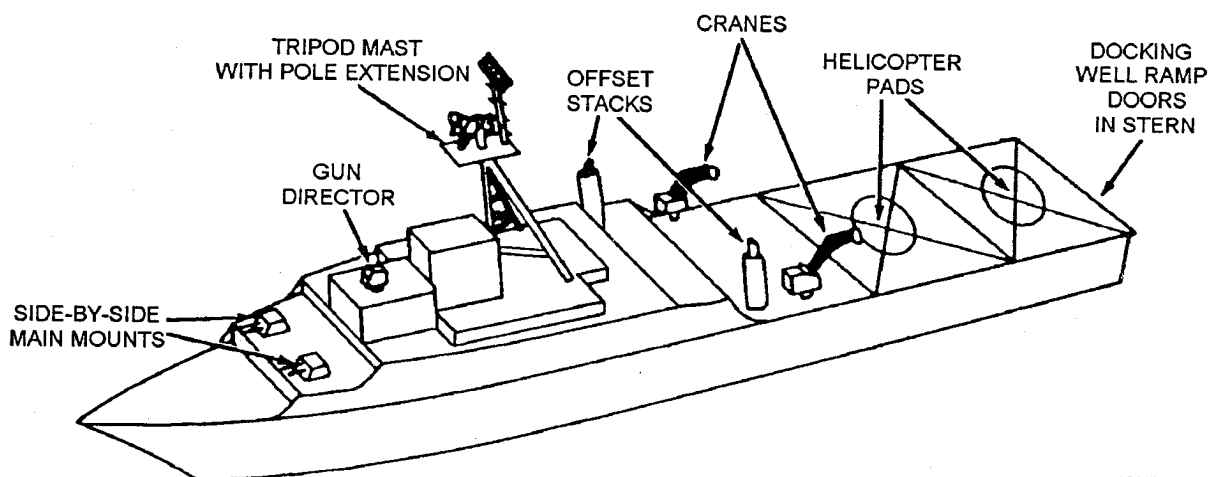

ISNP0071

Figure 6-21.—Large amphibious ship.

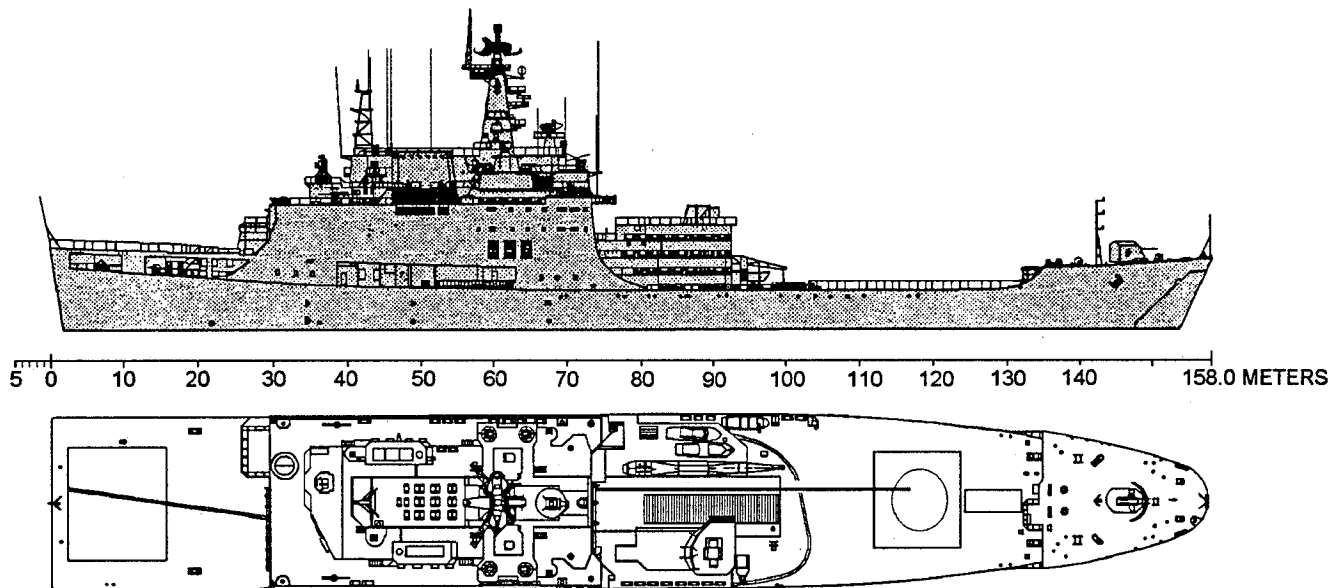

ISNP0072

Figure 6-22.—IVAN ROGOV-class LPD.

One particular type of auxiliary that receives the complete attention of both operations and intelligence personnel is the CIS intelligence collector, or AGI. Because AGIs pose a significant intelligence collection threat to our fleet, we will discuss them in detail.

INTELLIGENCE COLLECTORS— only ships that have a primary mission of collecting information of intelligence value are designated AGI. However, nearly any type of ship can be quickly adapted for a temporary intelligence collection mission by the addition of portable equipment. Historically, the former Soviet Union used fishing trawlers, whale catchers, tuna factories, refrigerated transports, light cargo ships, research ships, tugs, naval auxiliaries, and even buoy tenders for electronic intelligence collection. While many of these types were only intermittently active, a significant force of ships was permanently assigned to the AGI role. The most common collectors were conscripted from the fishing industry. This section is concerned only with permanently configured collectors.

Other AGI classes are associated with research and rescue. These are the NIKOLAY ZUBOV-class and MOMA-class research ships and the PAMIR-class ocean rescue tug. The PRIMORYE-class AGIs were the first intelligence collectors to be built from the keel up as AGIs, although their design is basically a modification of the MAYAKOVSKIY fish factory ship. A newer and larger class of intelligence collector, the BALZAM, has joined the CIS fleet. Both BALZAM

and PRIMORYE carry highly sophisticated arrays for intercept and jamming.

The major recognition feature of all AGIs is the large quantity of electronic equipment throughout the deck and superstructure. Also, some AGIs are fitted with surface-to-air missiles and/or anti-aircraft guns.

Submarines

Submarines are the most elusive of all naval ships. To locate and prosecute (track) a submarine successfully is a formidable task—one to which a good portion of our Navy is devoted. Nuclear-powered (nuke) submarines almost always stay submerged when operating out of their home area. Infrequently, a nuke may be forced to surface because of an engineering casualty, to transfer a seriously ill crewmember, or to conduct an exercise with a submarine tender (AS) or missile tender (AEM). These rare ventures to the surface will more than likely occur under cover of nightfall and in an isolated area. On the other hand, because they must recharge their batteries, conventionally powered submarines must surface more frequently than nukes and are less discreet about when and where they surface.

CIS SUBMARINES.— The CIS continues to build high-technology submarines with pressure hulls made of titanium. This development enables their submarines to operate at greater depths than their predecessors and makes them more survivable because of greater hull strength.

In the next section, we will discuss submarine recognition features, including nomenclature and profiles, and then cover the capabilities and missions of the various types of submarines.

RECOGNITION FEATURES.— The exterior view of submarines presents a very low silhouette. This is because submarines have a low center of gravity and, therefore, are normally two-thirds submerged while on the surface. The exterior hull of submarines has a cylindrical shape that gradually tapers forward and aft to become the bow and stern, respectively.

On older conventional submarines, the superstructure deck—called the main deck—extends virtually from the tip of the bow to near the stern. The deck is generally level. Beginning near the midship section, the deck rises gradually in the direction of the bow to a height of about 10 feet above the waterline. The freeboard of the after end of the main deck is about 4 feet.

The main deck is attached to the exterior hull by means of the framing and rounded sides. “Limber holes” allow seawater to enter all the hollow spaces in

the superstructure and the deck when the submarine is diving and to drain off when it is surfacing.

The midship section of the main deck has a large fairwater structure, usually called the sail. This structure normally consists of the conning tower, observation bridge, and housing for electronic and other equipment.

SUBMARINES OF AN OLDER DESIGN.— Refer to figure 6-23 as you study the function descriptions of an older submarine. The forward, or bow, section of the main deck normally has the following installations: a sonar head (often called a sonar dome) (1); a capstan (2), which is often retractable; a marker buoy (3), which can be released to the surface and is sometimes equipped with a direct telephone line; a rescue hatch (4), which is designed for rescue purposes but may also be used for normal access; and a loading hatch (5) for forward torpedoes.

The bow section may be fitted with torpedo-tube shutter doors (6); a “chin”-mounted sonar dome (7); retractable, foldable diving planes (8), which are used for ascension or to maintain a specific attitude; and hydrophones (9) or other retractable sound equipment.

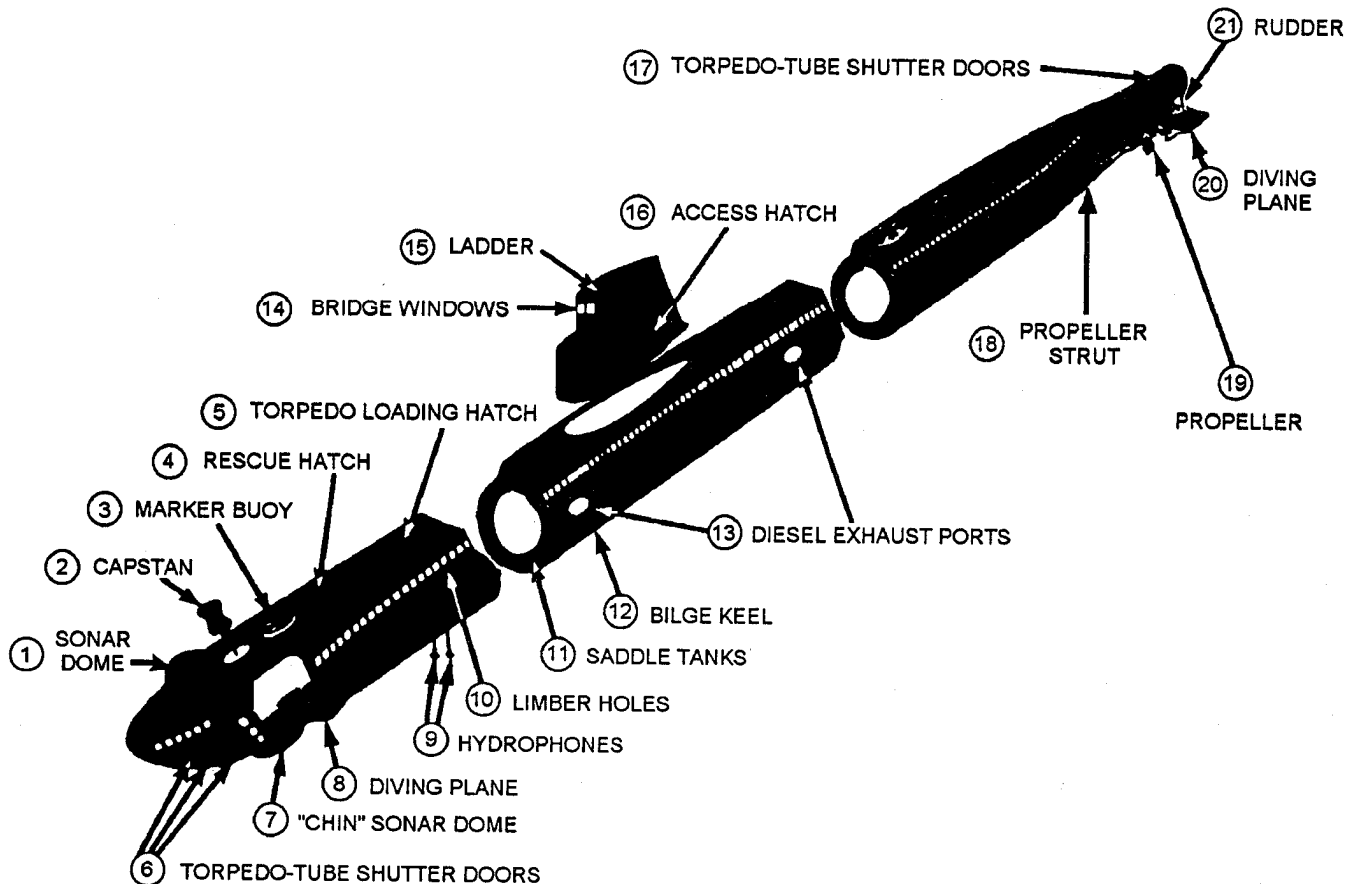

Figure 6-23.—Older submarine.

ISNP0073

Running from the bow section through the midship section and terminating in the after section, free-flooding ports—called “limber holes” (10)—may be arranged in various patterns. On older submarines, saddle tanks (11) form a noticeable bulge in the hull shape. A bilge keel (12) would be evident if the hull were raised out of the water. Diesel exhaust ports (13) are located at the waterline.

Windows in the sail (14) indicate an all-weather navigation bridge. The bridge area may be fully enclosed, partially enclosed, or open. A ladder (15) and an access hatch (16) are sometimes visible on the sail.

The stern section has deck structures similar to the bow section (marker buoy, rescue hatch, access hatch, capstan, and so forth). The stern area usually contains fewer torpedo-tube shutter doors (17) than are fitted in the bow section. Propeller struts (18) and propellers (19) are usually located port and starboard. Control surfaces at the stem include movable diving planes (20) and a rudder (21).

MODERN SUBMARINES.— Modern submarines still retain most design features developed and proven over the years, but new external styling is evident (figure 6-24). The basic hull shape resembles a torpedo, with a rounded nose and control planes at the stem set at right angles to each other. Other surfaces show streamlined fairing. The modern submarine has many of the following prominent recognition features:

1. A sonar belt or sound-transparent window may encircle the bow. This belt usually consists of a bright metallic plating that allows sound to pass through the bow with very little loss of energy.
2. Sonar plates are another type of belt of similar material that may encircle the lower sail front.
3. Rectangular, streamlined, or stepped sails with retractable gear wells may be exposed and conform to the maximum size and shape of the gear contained. Recent models have flush fairings in the form of hatch covers, folding doors, and contoured tops.
4. Many modern submarines have sail planes because they provide increased depth stability.
5. Missile tube hatch covers appear in a variety of patterns. Vertically installed tubes may be located within the hull aft of the sail or within the sail itself. When tubes are installed aft of the sail, the main deckline is raised to allow headroom for the tubes, forming a hump (or “turtleback”) in the hull profile.
6. Stem fins provide one of the most prominent features of modern submarines. The vertical fin, which incorporates an extended rudder surface, extends well above the main deckline. Some fins are set at a 45° angle to the vertical and are not so readily apparent.

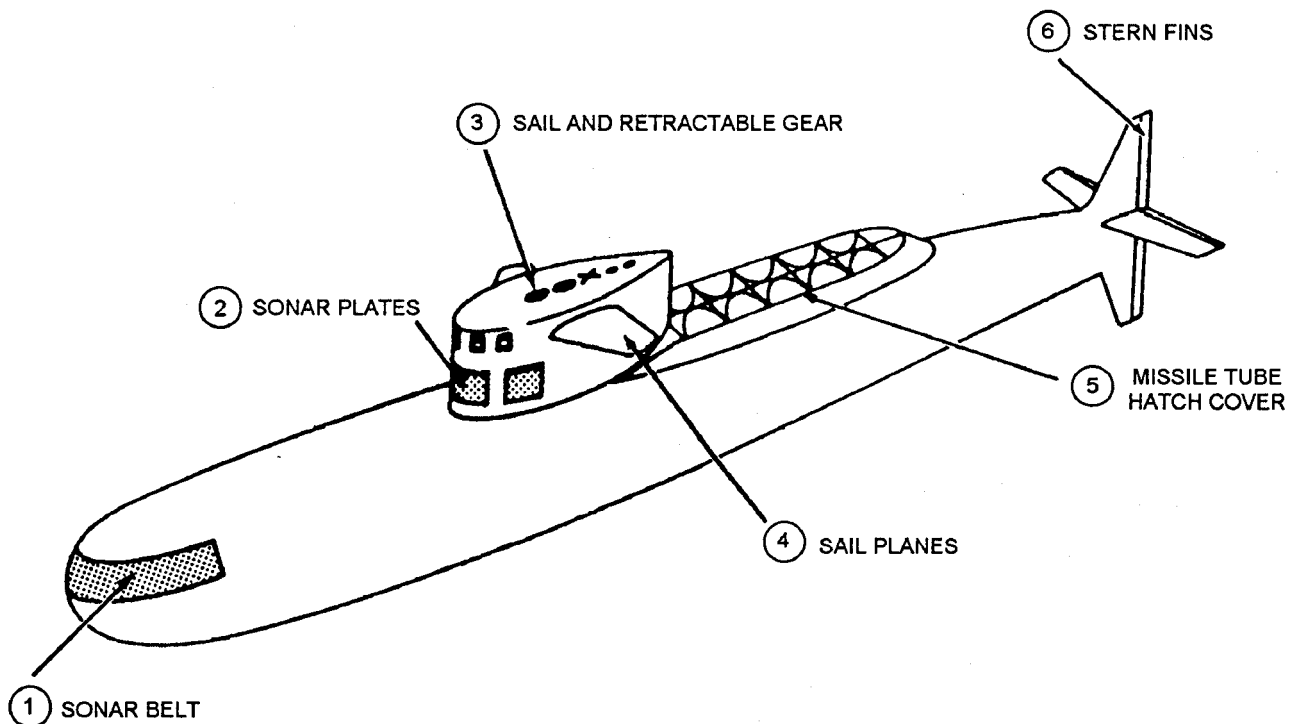

Figure 6-24.—Modern submarine.

ISNP0074

TYPICAL RETRACTABLE GEAR.— Figure 6-25 shows typical retractable gear contained in the submarine sail. The shape, sequence, and combinations will vary extensively; but, generally, most submarines have the following equipment:

1. An attack periscope;
2. A reconnaissance or search periscope (characterized by having an enlarged head window) ;
3. A navigation/search radar;
4. An air-induction valve (often called the snorkel intake);
5. A direction-finding antenna (often some type of DF loop);
6. One or more communications masts for various radio-frequency ranges;
7. An antenna housing various EA/ES and IFF installations;
8. A snorkel exhaust valve, which may take the form of a fixed installation within the sail; and

9. Running lights, which maybe fixed, recessed, retractable, or folded flush into the sail when not being used.

Other features often observed on the sail are electronic navigation devices, searchlights, fold-down windshields, guardrails, and a ladder.

GENERAL RECOGNITION FACTORS.— The streamlined “turtleback” sail, a Soviet innovation, has a curved topline that merges with the after trailing edge of the sail. For division and classification, this new sail design is assigned Appearance Group Code 1.

Rectangular sails are so numerous that they must be broken down into subdivisions as they appear in relation to other features. The new SSBNs usually have a rectangular sail with sail planes. They also have a bullet-shaped bow, astern fin, and a prominently raised and broken declivity aft of the sail (a feature needed to accommodate upright missile tubes). The SSBN classes largely constitute Appearance Group 2.

Other appearance types with rectangular sails compose Groups 3, 4, and 5. In these groups, hull features, such as stern fin and bow type, are the differentiating factors.

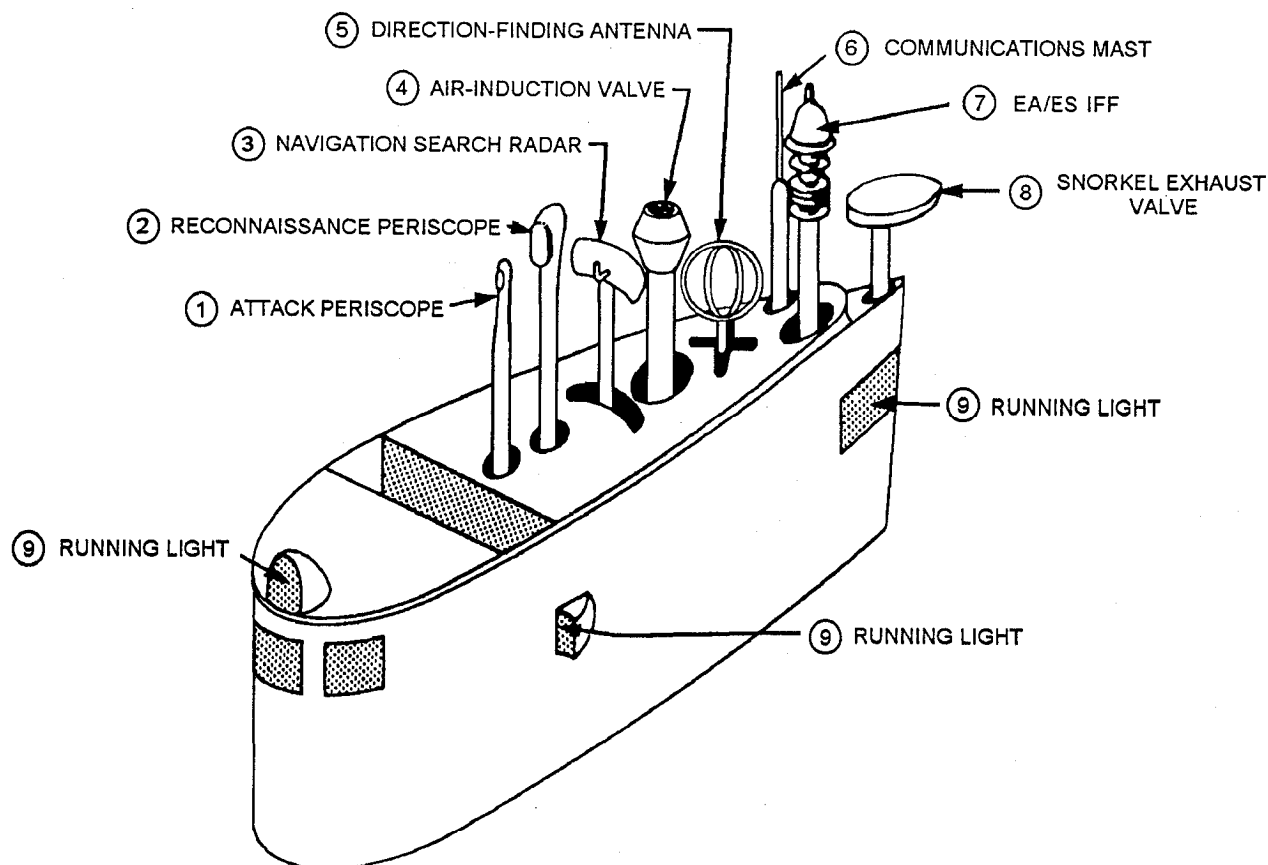

Figure 6-25.—Typical retractable gear.

ISNP0075

Appearance Group 6 includes a small group of transitory types of design. In this group, the overall appearance of the sail is rectangular, but the topline is broken with minor knuckles, protuberances, and fixed or semi-retractable equipment. If a small step occurs, it measures less than one-fifth of the sail height and usually indicates a shield, a raised well cover, or a fixed snorkel exhaust casing. Generally speaking, this group is composed of conversions and experimental prototypes that bridge the gap between the irregular shapes of the World War II versions and the streamlined sails of the nuclear age. If the sail topline is broken and has an obvious step measuring one-fourth of the sail height or more, it falls within Groups 7 through 9, depending on the position of the step.

TYPES OF SUBMARINES AND MISSIONS.—

There are various types of submarines. For the purpose of our discussion, we will categorize submarines into three distinct groups; attack, cruise missile, and ballistic missile. All three groups include both conventionally powered (diesel/electric) and nuclear-powered submarines.

Attack Submarines.— Attack submarines (SS and SSN) are used primarily against shipping, both surface and subsurface. These submarines are designed for speed and maneuverability. Attack submarines use torpedo tubes, usually located forward and aft, to launch torpedoes, mines, and, in the case of some newer SSNs, missiles.

Cruise Missile Submarines.— Cruise missile submarines (SSG and SSGN) are designed primarily to attack surface ships. Their armament usually consists of surface-to-surface antiship missiles, torpedoes, and mines. Cruise missile submarines often prey on carrier battle groups and other high value unit (HVU) battle groups.

Ballistic Missile Submarines.— Ballistic missile submarines (SSB and SSBN) are probably the most notorious of all submarines. Ballistic missile submarines usually maintain constant patrols (relieving one another on station) that place their long-range surface-to-surface missiles within range of intended targets, such as major military and industrial

installations. Figure 6-26 shows a CIS DELTA-class SSBN.

MERCHANT SHIP INTERPRETATION

As an IS3 or IS2, you must be able to identify and report the various types of merchant ships. Intelligence analysts depend on your merchant ship reports to formulate analyses relevant to both political and naval intelligence. Many countries use merchant ships for military-related functions. Merchant ships used as arms carriers warrant considerable attention because by closely monitoring arms carriers, we can better understand political ties and keep abreast of the military Order of Battle (OOB) and capabilities of recipient countries. Another important reason for merchant ship interpretation is that the Commonwealth of Independent States (CIS) often uses merchant ships to replenish its naval forces.

The primary publication that will help you identify merchant ships is the *Merchant Marine Identification Guide—World*, DST-2050G-001-YR. This publication provides up-to-date characteristics and identification data on most nonmilitary ships.

Any system used for identifying and reporting merchant ships during peacetime must be adaptable to wartime use as well. Such ordinary aids to identification as stack markings, hull and superstructure paint combinations, striping, and house flags, all of which can be of great assistance in peacetime identification, are easily camouflaged or painted over. Consequently, we must rely on those prominent physical characteristics that are readily seen and difficult to alter or disguise.

AIRCRAFT INTERPRETATION

Aircraft identification is an integral part of airfield interpretation. Although you will soon become familiar with the most frequently used types of aircraft, you should guard against making positive identifications hastily. The identity of every aircraft must be checked by even the most expert interpreter. You should study unidentified aircraft carefully, using all available

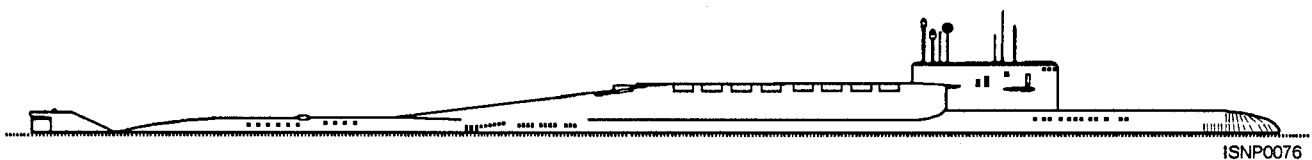

Figure 6-26.—DELTA-class SSBN.

references on recognition and identification. The dimensions and characteristics of all known aircraft are available from many sources, including imagery interpretation (II) keys, such as the *Joint Imagery Interpretation Keys Structure (JIIKS) Aircraft of the World (U)*, DIAM 57-7 series, Volume XII; and *Jane's All the World's Aircraft*.

The identification and location of enemy aircraft, together with such known items as their range, operational limitations, support requirements, and normal weapons configuration, enable our commanders to plan for both offensive and defensive operations. Recognizing, identifying, and reporting the location of all aircraft are essential to keeping air order of battle (AOB) information current. So that our commanders and national policy decision makers can make timely decisions, AOB information is vitally important, in both peacetime and wartime.

Fighter aircraft and jet bombers are relatively easy to identify on good-quality imagery, thus aiding you in determining the type and purpose of an airfield. This section deals specifically with aircraft identification features. Mission and tactics will be discussed in volume 2 of this manual.

Aircraft Types

When the scale or quality of imagery makes it difficult to identify the type of aircraft (jet or prop), you must rely on distinguishing characteristics to aid in identification. A single-engine jet, as opposed to a single-engine propeller-driven aircraft, has one or more of the following recognition characteristics:

- The wings are farther back from the nose.
- The widest part of the fuselage is near the center.
- The wings are usually angled (tapered, swept, or delta) back, inboard to outboard.
- The wings usually have less surface area.
- The distance from the wings to the horizontal stabilizer is less than that from the wings to the nose.

There are fewer visible differences between multi-engined jet aircraft and multi-engined propeller aircraft than between the single-engine types. However, the twin- and multi-engined jets usually have one or more of the following recognition characteristics:

- The wings are usually angled (tapered, swept, or delta) back, inboard to outboard.

- The engines are usually suspended from the wings (the engine nacelle is usually in the wings on propeller types).
- The wings have less surface area.

Aircraft Measurements

The two major characteristics in aircraft interpretation are the size of the image and the shape of

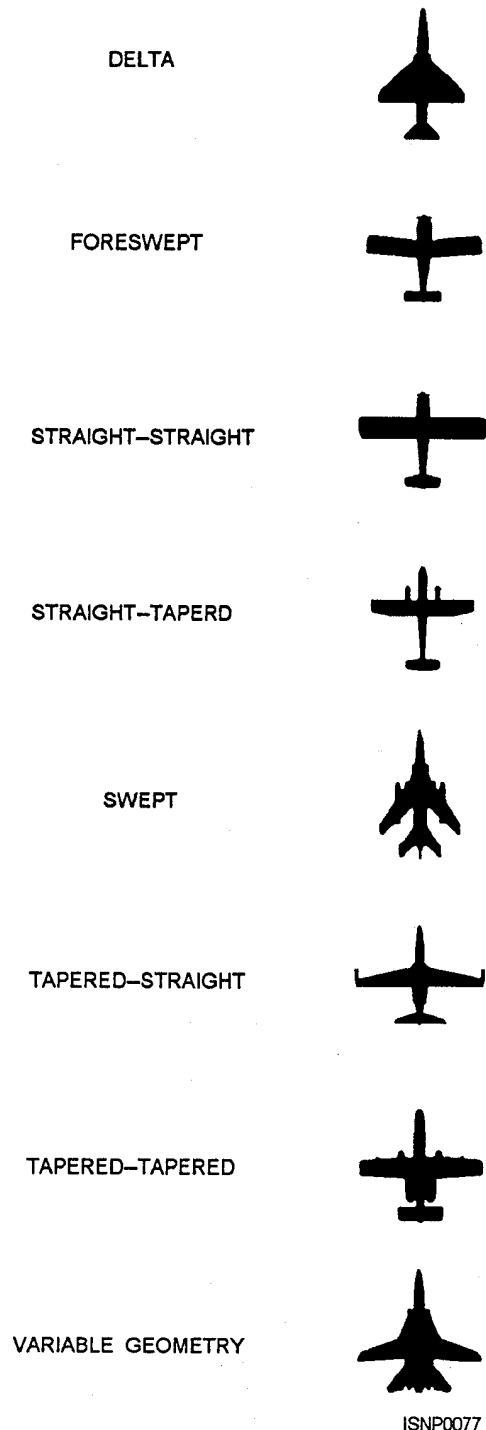
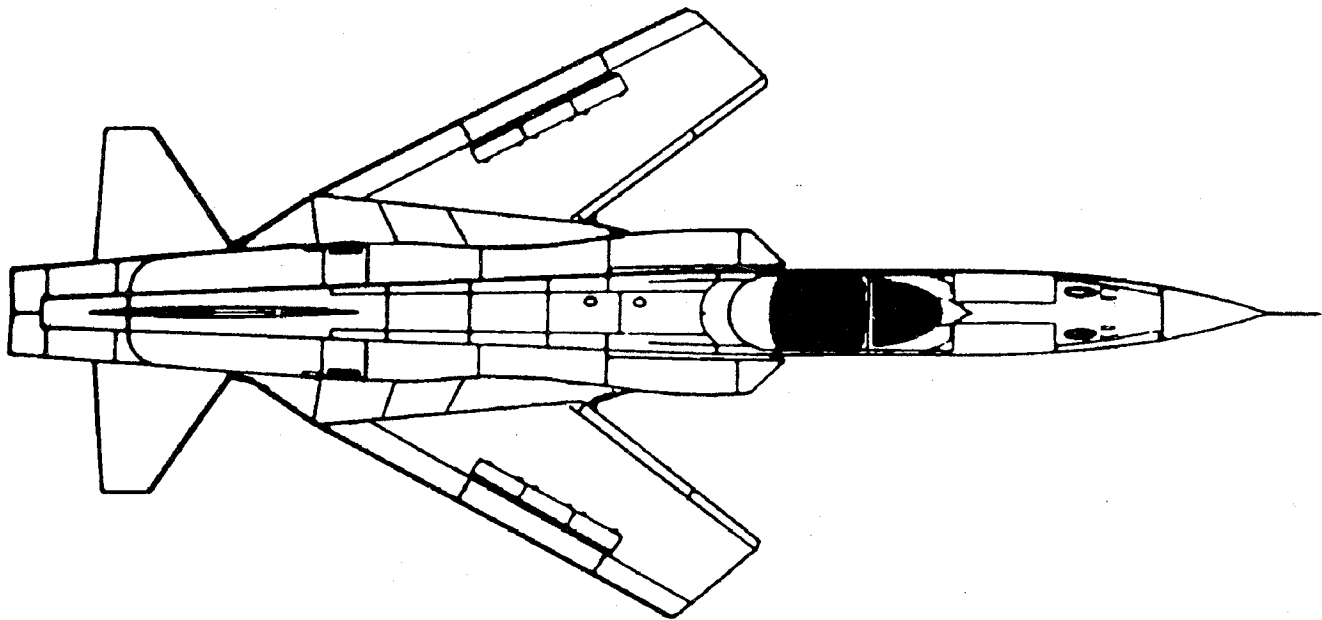

Figure 6-27.—Wing shapes.



ISNP0078

Figure 6-28.—Ultraforward swept wing.

the various components. Accurate measurements are vitally important because the general appearance of certain aircraft may often be so similar that only the difference in wingspan provides the final clue for identification.

Aids to Identification

The study of aircraft shadows can often lead to identification. Since shadows tend to overemphasize aircraft features, it is sometimes better to study the shadows than the aircraft itself. Wing shadows, however, are misleading because of their relation to the direction of light, their upsweep or dihedral, and the ground angle of the aircraft. Nose shadows are helpful; even transparent noses will cast a shadow where there is rear lighting. Under conditions of rear lighting, the shadows of the nose, engine, nacelles, and gun turrets are well-defined. Fin and rudder shadows also provide important recognition features.

The identification of aircraft on aerial imagery requires an orderly procedure. The procedure in current use is called WEFT, the acronym for wings, engine, fuselage, and tail.

WING CHARACTERISTICS.— Because of their size and shape, the wings of an aircraft are perhaps the easiest aircraft component to identify. The wings constitute the most important identification feature on vertical imagery. The identifiable features of the wings are their overall shape (figure 6-27) and the shape of their tips. Wing shapes are generally classified

according to their taper, amount of sweepback, design of the leading edge, symmetry, or delta configuration. Recent technological advances in aerodynamics have spawned the development of a unique ultraforward swept wing (figure 6-28), which may lead to a new line of super-fast, advanced tactical fighters (ATFs) with enhanced maneuverability, expected to be used jointly by the Navy, Marines, and Air Force.

ENGINE CRITERIA.— We discussed the methods of determining engine type (jet or prop) under “Aircraft Types.” Identification of the type, number, and location of engines, used in conjunction with II keys, will help you identify aircraft. For example, the Russian-built Tu-95 BEAR is the only turboprop-powered heavy bomber in the world. The wing mounts four turboprop engines with coaxial, counterrotating propellers. As shown in figure 6-29, each engine nacelle protrudes forward of the wing, but only the inboard engines have landing gear nacelles that extend aft of the wing.

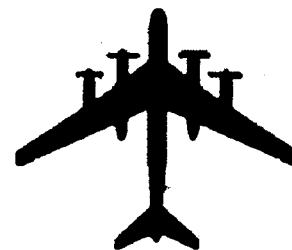

ISNP0079

Figure 6-29.—Vertical silhouette of Tu-95 BEAR.

FUSELAGE.— Use of the fuselage in aircraft recognition is primarily restricted to its size and shape (figure 6-30) and the shape of its nose section. Nose sections may also be glazed or have a shock cone. In some jet models, you may be able to locate the air intakes if the imagery is of satisfactory quality. Seaplanes have very distinct features in their fuselage design, but such design characteristics are often

difficult to determine on vertical imagery. Shadows can be of great help in this regard.

TAIL SURFACES.— Recognition characteristics of tail surfaces are generally concerned with the shape and location of the horizontal stabilizer, since the vertical stabilizer is difficult to analyze in vertical imagery. The basic features recognizable in the horizontal stabilizer are very similar to those used for

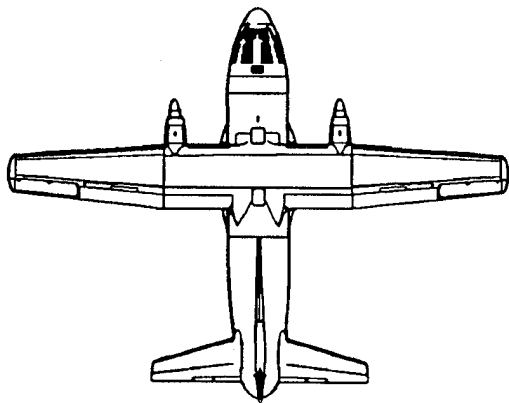

BARREL

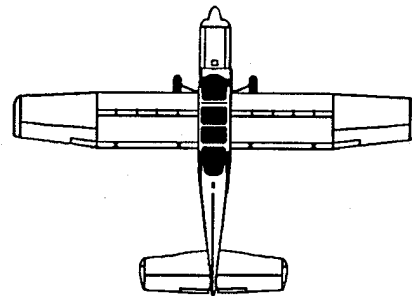

LOBE

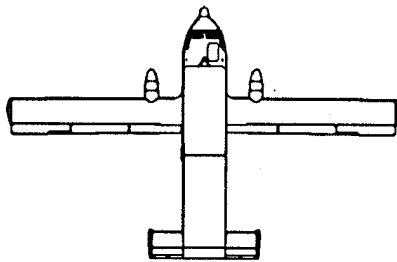

RECTANGULAR

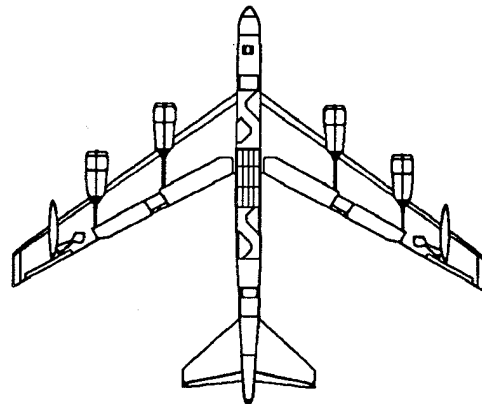

CIGAR

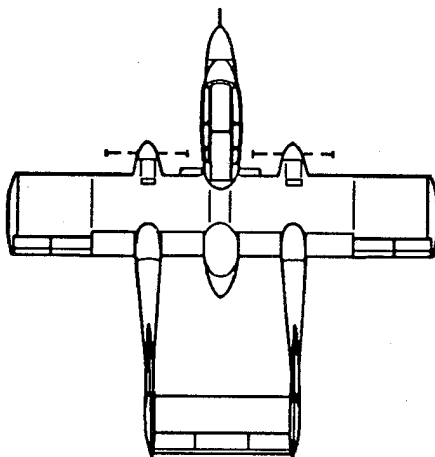

NACELLE

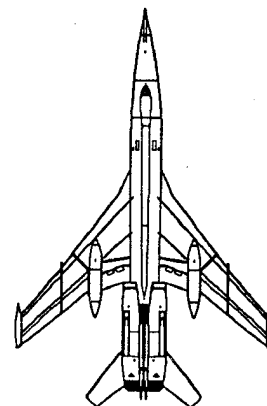

TUBE

ISNP0080

Figure 6-30.—Fuselage shapes.

identifying wing surfaces—shape (such as swept, straight-tapered, or tapered-tapered) and tip shape (such as square, clipped, or rounded).

Another item that can be of help is the position of the horizontal stabilizer. For example, it may be located below the axis of the fuselage (the centerline), at or near the top of the fuselage, or upon the vertical stabilizer above the fuselage. (See figure 6-31.)

Hazards to Identification

Aircraft identification from vertical imagery may pose some significant problems. Numerous distortions and other difficulties may confuse you. Some of these are:

- Engine nacelles or mountings often cannot be seen on small-scale imagery, particularly when the nacelles extend only a short distance beyond the edge of the wing.
- Transparent parts, such as the noses of certain types of aircraft, frequently cannot be seen. Unless aided by a forward shadow, which results from rear lighting, you can be easily misled.
- When an aircraft is seen in side light, the wing nearer the light is sometimes not visible. Small aircraft are frequently overlooked on small-scale imagery, because their fuselages are not easily visible. Occasionally, because of side lighting and camera position, both wings of an aircraft do not appear to match. In this case, the imagery

cannot be taken literally. Normally, it is better to assume that the larger of the two wings is the more reliable guide to size and shape.

- The appearance of an aircraft on aerial imagery is often distorted by halation (a film defect). Halation surrounding an object makes the object appear larger than it actually is, blurs its outline, and gives it a flat “absorbent cotton” look. In measuring aircraft affected by this phenomenon, you must consider several factors: tapered wings appear less tapered, square-cut wings appear somewhat rounded, and wing position is difficult to determine because of the disappearance of fuselage shadows.
- Most recognition views of aircraft are taken while the aircraft is in flight. Except for aircraft with a tricycle landing gear, this view is different from the vertical view of an aircraft parked on the ground. Under these conditions, the tail is dropped far below its normal in-flight position, which makes the wings appear more slender, often changing the appearance of the taper. The sweepback is greatly exaggerated, and the curve of the wingtips appears more acute. The landing angle also plays curious tricks with shadows.
- Camouflage adds greatly to the difficulties of identification. Aircraft may be covered with large nets, brush, or foliage. This hides the aircraft from view, thus preventing identification if discovered.

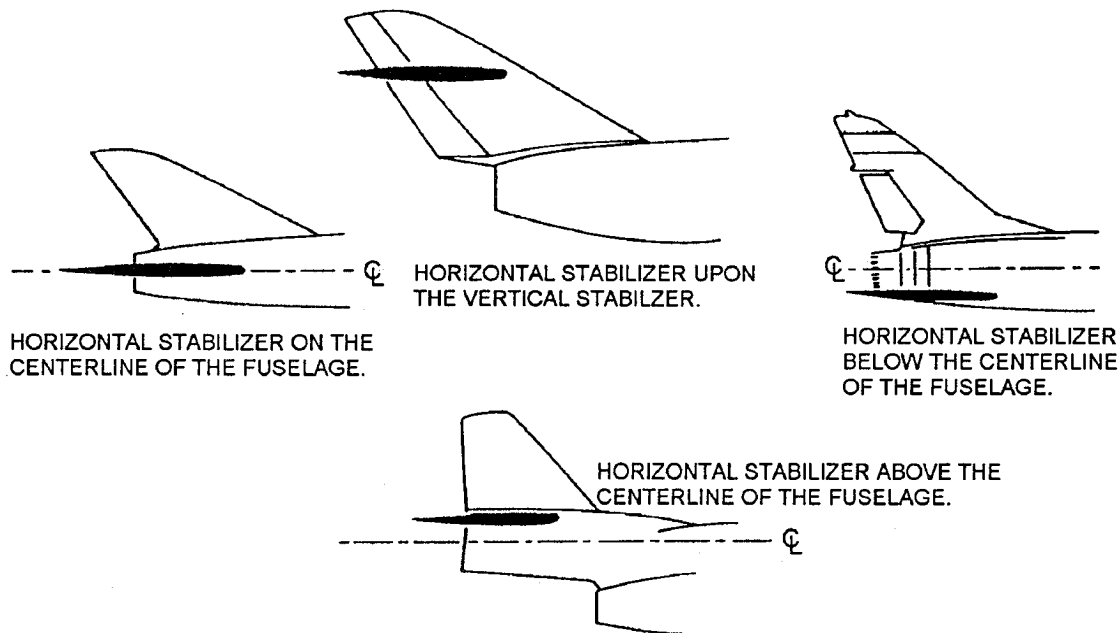

Figure 6-31.—Position of horizontal stabilizer.

ISNP0081

- You should always exercise care to ensure that the aircraft are not dummy aircraft, decoys, or painted shapes. A lack of relief is very apparent in the latter case.

A number of recognition aids are available that provide the various wing and tail markings of both civil and military aircraft. Proper identification of these markings can be of great help in determining the nationality and use for which the aircraft are intended, as well as the use of the field on which they are located.

Helicopter Identification

Helicopters are among the most easily recognized types of military equipment. The term “rotary-wing aircraft” includes those aircraft that depend primarily on lift from their rotary-propulsion systems. Also, the maneuverability and the forward thrust are controlled either by the rotor system or by an auxiliary engine system. For purposes of our discussion, aircraft meeting these criteria are called helicopters.

RECOGNITION FEATURES.— The primary recognition features used in helicopter identification are the rotor system and the number of main rotor blades (never fewer than two). After determining the type of rotor system and number of blades, you should refer to

Joint Imagery Interpretation Keys Structure (JIIKS) Military Aircraft of the World(U), DIAM 57-7, Volume XII, Part 4 (Communist) and Part 5 (Non-Communist) for final determination of the model type.

Other factors that will assist you in helicopter identification are the shapes of the fuselage and tail boom and the presence or absence of wings. Figure 6-32 shows these and other recognition features.

CIS HELICOPTERS.— Over the years, there has been a vast increase in the number and types of Soviet-built helicopters. This growth reflects a change in CIS theories regarding the use of rotary-wing aircraft. Traditionally, Soviet-built helicopters were designed to perform only liaison, transport, and medical evacuation missions. In recent years, however, models designed for airborne assault, antisubmarine warfare (ASW), scout, command and control, and attack roles have appeared. This increased production indicates the growing importance the CIS attaches to the helicopter as a military vehicle.

For purposes of identification, CIS helicopters are divided into three major groups by rotor systems. The most common type is the single-rotor system. The second type is the coaxial-rotor system in which two

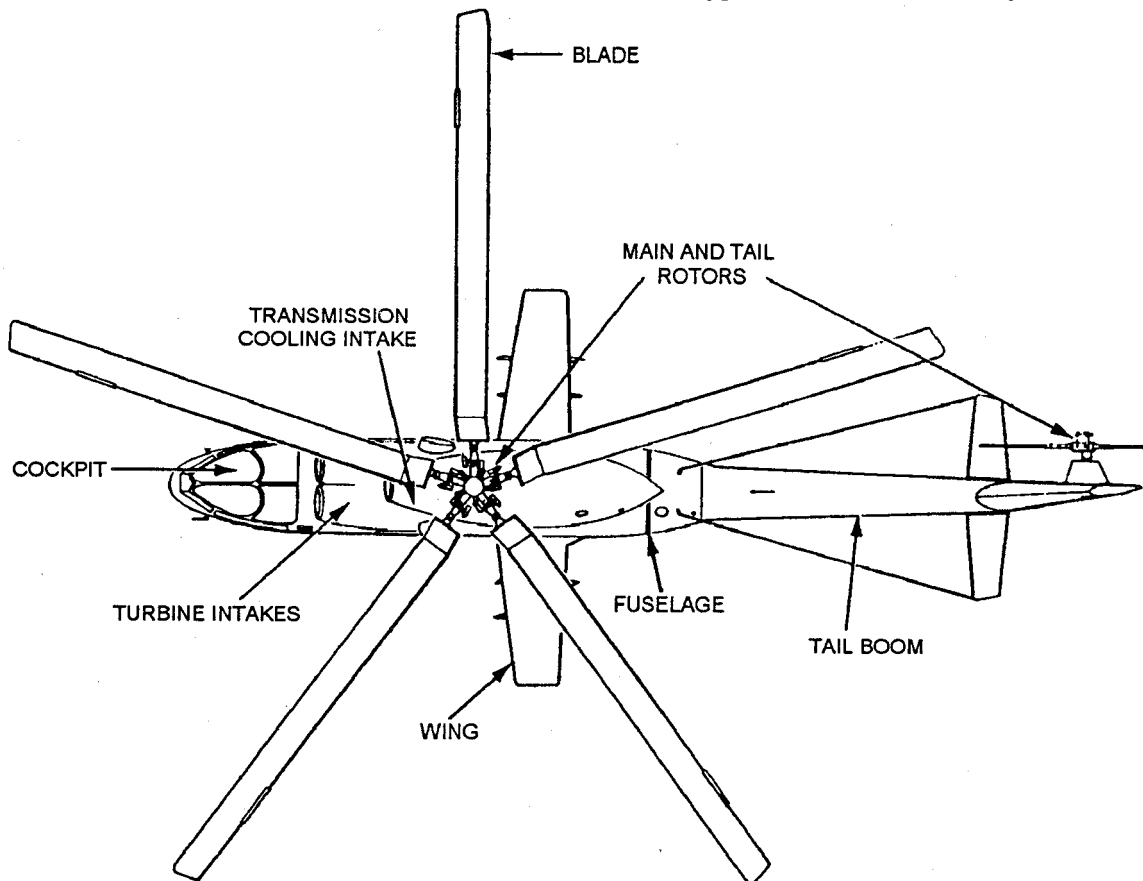

Figure 6-32.—Helicopter recognition features.

ISNP0082

rotors have the same rotor shaft. The third system has dual rotors laterally mounted on the wing tips. These three systems are shown in figure 6-33.

CIS AIRCRAFT DESIGNATIONS

CIS aircraft are assigned both NATO and CIS designations. A NATO code name is assigned that indicates the aircraft type and the specific aircraft. The CIS method of identifying the aircraft is by design bureau and sequence of the aircraft.

The following NATO scheme was adopted in 1954; name assignments are made by the Air Standards Coordinating Committee:

B —Bomber (one-syllable names for propeller aircraft and two-syllable names for jet aircraft);

C —cargo;

F —Fighter;

H —Helicopter; and

M —Miscellaneous (fixed-wing, including maritime patrol aircraft).

Suffix letters are appended to the NATO code names to indicate variants of a basic aircraft. The addition of these variant suffix letters to the CIS (former Soviet) designations, such as Tu-95D, is incorrect.

Russian-design bureau designations were based on the following code, derived from the names of the founders of the specific bureaus:

Be —Beriev;

Il —Ilyushin;

Ka —Kamov;

Mi —M. L. Mil;

Mig —Mikoyan;

Su —Sukhoi;

Tu —Tupolev; and

Yak —Yakovlev.

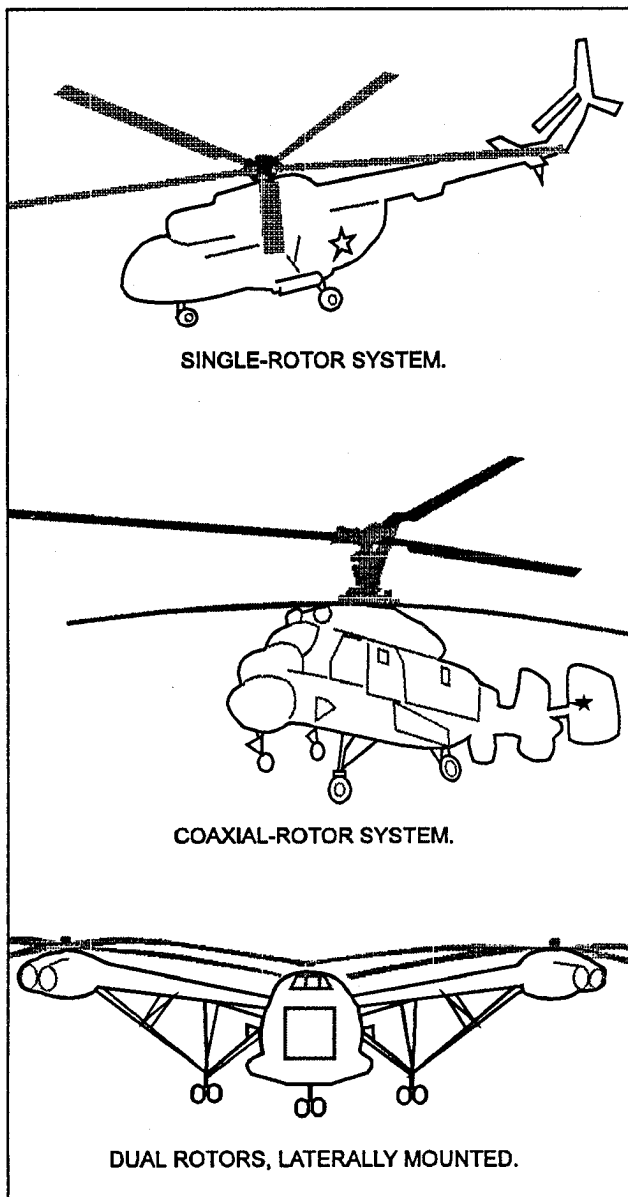

Figure 6-33.—CIS helicopter rotor system.

The Russian government adopted this basic scheme in 1940 (although aircraft designs supervised by Andrei N. Tupolev carried the bureau prefix ANT until 1947). The numbers used in conjunction with these bureau designations indicate the manufactured sequence of the aircraft, with two numerical series used for some aircraft, one indicating the bureau design and one the (later) military designation. Suffixes are used with the bureau designations, the most common ones being *bis* for later variants, *M* for *modifkatsirovanny* (modification), *R* for *razvedchik* (reconnaissance), and *U* for *uchebno* (instructional—for trainer version).

We have intentionally omitted extensive coverage of specific Soviet-built aircraft from this manual. To keep abreast of ever-changing CIS aircraft developments, you are strongly encouraged to study the publications referenced in this chapter. Many free-world aircraft (such as the MIRAGE) are being exported throughout the globe and should also be included in your studies.

MISSILE INTERPRETATION

A missile is any object or weapon that is thrown, shot, or otherwise propelled to a target. In this chapter, we will deal mainly with Soviet-built missile systems.

We will compare and discuss the various types of missile systems, including the methods of deployment.

Because classification constraints prevent detailed discussion of missile systems in this chapter, you should become familiar with the publications cited throughout this chapter, particularly the *Naval Intelligence Products Register (NIPR) (U)*, ONI-2660A-0001-YR. The NIPR provides titles and numbers for many intelligence publications, including many that deal with specific foreign missile systems.

Missile Characteristics

Although all missiles are generally similar in shape (long and slender) and often have small wings or fins, they vary greatly in size. They range in length from 4 feet to over 100 feet and vary in diameter from 1 to 12 feet. Missiles are seldom seen because they are usually concealed in containers or beneath coverings, except during testout or launching and military parades. You can find sizes and features of the various missiles in a number of publications, including the JIIS and the *DIA Fact Book—Communist World Forces (U)*, DST-2660Z-013-YR.

It is often useful to classify missile systems by mission, because the systems differ widely in many respects.

Missile Classifications

Although missiles may be conveniently classified according to their manner of flight (ballistic or cruise), a much broader classification is used for an entire missile system. A system may be described in terms of the location of the launcher and the target, range or purpose, or mobility. In this chapter, missiles will be classified by their purpose. A description of a missile system should contain all the classifications and the strategic or tactical application of the system. For example, a description, such as “a surface-to-surface, strategic ballistic missile system with fixed launching facilities,” provides a complete and useful reference. The following classifications are the standard references for missile systems. Each of these classifications is important to imagery interpretation.

- **LOCATION OF LAUNCHER AND TARGET:**

- SSM—Surface-to-surface;

- SAM—Surface-to-air;

- ASM—Air-to-surface;

- AAM—Air-to-air;

- USM—Underwater-to-surface;

- AUM—Air-to-underwater;

- SUM—Surface-to-underwater;

- UUM—Underwater-to-underwater;

- **RANGE:**

- ICBM—Intercontinental (3,000 miles or more);

- IRBM—Intermediate range (1,600 to 3,000 miles);

- MRBM—Medium range (1,000 to 1,599 miles);

- SRBM—Short range (less than 1,000 miles).

- **PURPOSE:**

- Antiballistic (ABM);

- Antiaircraft (SAM);

- Antitank (ATM);

- Antiship (SSM, ASM).

- **DEGREE OF MOBILITY**

- Fixed launch facilities;

- Mobile launch platform.

Strategic Missiles

Strategic missile systems support the policies and plans of a country at both the national and international levels. These systems are intended to render an enemy incapable of waging war through potential or actual large-scale, long-range attacks on his missiles and his command and control system, thus ensuring security or victory. The following missiles are classified as strategic missiles:

- All surface-launched ballistic missiles;

- All submarine-launched ballistic missiles; and

- Air-to-surface missiles deployed on strategic bombers.

Tactical Missiles

Tactical missile systems support the on-scene commander. There are many different types of tactical missiles, such as surface-to-surface missiles (SSMs), surface-to-air missiles (SAMs), air-to-air missiles (AAMs), and air-to-surface missiles (ASMs). Tactical missiles may be offensive or defensive in nature and have much shorter ranges than do strategic missiles.

From the imagery interpretation standpoint, it is convenient to describe the types of missile systems by their intended purpose as follows:

SURFACE-TO-SURFACE MISSILES.—

Surface-to-surface missiles (SSMs) are of two types: ballistic and cruise. Many surface-to-surface rockets are very similar in appearance to missiles; however, SSMs are guided either completely or partially to their intended target while rockets follow an unguided path.

“Surface-to-surface,” as used in this section, implies that the launch system is near ground level. The actual launch platform may be underground in silos, fixed permanently above ground, or mobile.

Ballistic missiles makeup the largest portion of the SSMs currently deployed by the CIS. Strategic ballistic missiles are long-range weapons that are targeted against a potential enemy’s major military and industrial installations. Many strategic ballistic missiles have multiple independent re-entry vehicles (MIRVs), enabling one missile to cover a number of targets.

Ballistic missiles are divided into three range categories:

- **INTERCONTINENTAL**— A very-long-range ballistic missile designed to strike either area or point targets;
- **INTERMEDIATE AND MEDIUM**— A long-range system designed to strike either area or point targets; and
- **SHORT RANGE**— A strategic system designed to support ground forces in the field, primarily by strikes at point targets.

Ballistic missiles depend on tremendous thrust to overcome gravity. They have no wings but may have small fins for stability and minor flight trajectory corrections. A ballistic missile follows a path of trajectory during the majority of its flight; however, it may have a guidance system for making minor in-flight corrections to ensure a collision path with its intended target. Staging may be used in any of these missiles to extend their range. A stage is a section of the missile containing one or more rocket engines. In missiles with stages, a stage separates and drops away from the missile when its propellant is exhausted. Basically, the principles of deployment and construction of launch complexes for these ballistic missiles are the same. However, the number of launchers and associated facilities varies.

The CIS has both fixed and mobile ground-launched strategic ballistic missile systems. The mobile missiles are launched from Transporter-Erector-Launchers (TELs), making the systems extremely difficult to target or detect. Although best known for intercontinental use, CIS ballistic missiles have various ranges and purposes and vary in overall size, weight, and payload capabilities.

Cruise missiles are like pilotless aircraft; they depend on wings for lift after launch and to maneuver by altering course and altitude. The power plant and guidance system of cruise missiles are normally designed to operate throughout the entire flight.

Cruise missiles usually have much shorter ranges than do ballistic missiles. See figure 6-34 for a comparison of a ballistic missile and a cruise missile.

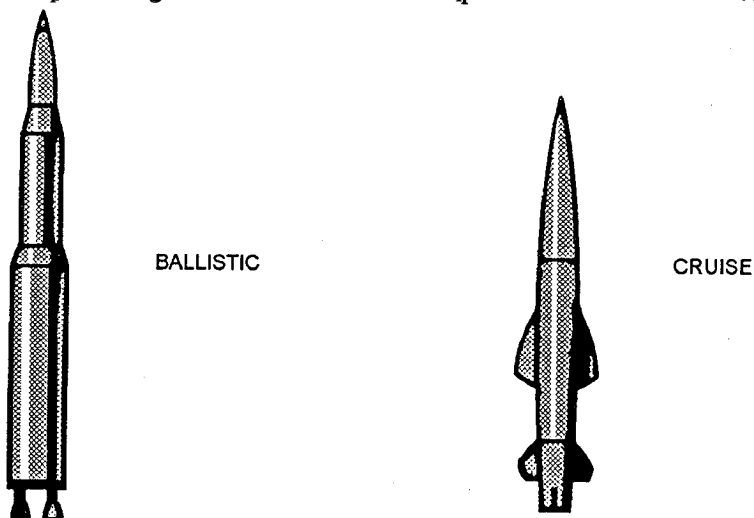

ISNP0084

Figure 6-34.—Ballistic and cruise missile comparison.

Modern cruise missiles, like the Tomahawk, have sophisticated guidance systems that use terrain masking and specific geographic coordinates to put the weapon on target.

SURFACE-TO-AIR MISSILES.— Surface-to-air missiles (SAMs) are the most sophisticated anti-aircraft defense and are designed to counter the threat of aerially delivered weapons. SAMs span the threat posed by high-speed, low-altitude attack aircraft to that posed by intercontinental ballistic missiles. Permanent SAM sites are most easily recognized by the essential presence of a radar and the configuration of the firing site or launch complex.

There are two basic types of SAM systems: (1) those designed for rapid deployment using mobile TELs and Transporter-Erector-Launchers and Radar (TELARs), and (2) those designed for deployment at fixed sites using ground-mounted launchers. Mobile SAM systems are used in tactical roles. Fixed SAM systems are strategically located to defend major military and industrial facilities, but are still considered to be tactical missile systems.

The major identifiable components of all SAM systems, except the shoulder-fired SAMs, such as the SA-7 (shown in figure 6-35), SA-14, and SA-16, are the missile, the missile transporter, and the associated radar. Other components that may be significant for certain systems are the launcher, missile canisters, and canister transporters. When the components are configured into an operational firing site, the site frequently assumes a recognizable pattern.

The vehicles used to transport missiles to the firing

site are unique to each system. Mobile systems use a single vehicle, called the TEL or TELAR, to transport and launch missiles. To keep a TEL or TELAR in the field, a special-purpose wheeled or tracked transloader is used for missile resupply. Figure 6-36 shows the SA-9 mobile SAM.

Fixed SAM systems use ground-mounted launchers. Missiles are delivered to the firing site by wheeled semitrailers or modified cargo trucks. By identifying the type of vehicle and the number of missiles it carries, you can often identify the missile system.

Each SAM system has a specific configuration of deployment at the firing site. The fixed systems usually have very pronounced patterns, whereas the mobile systems are less distinct. The major identifiable features are the number and placement of launching positions, the location of radar systems, and the pattern of access and service roads. Be sure to use caution whenever you identify a missile system by the site configuration alone, because some sites can accommodate several different SAM systems.

There are three main categories of radar in SAM systems: (1) target tracking and missile guidance radars, (2) target acquisition radars, and (3) early-warning radars. In a typical engagement, a target is first detected (at a distance) by an early-warning radar, which alerts the air defense system of the approaching threat and provides data for engagement decisions.

ANTITANK MISSILES.— Antitank guided-missile systems provide an accurate and relatively long-range weapon for use against armored vehicles.



Figure 6-35.—SA-7 GRAIL missile system.

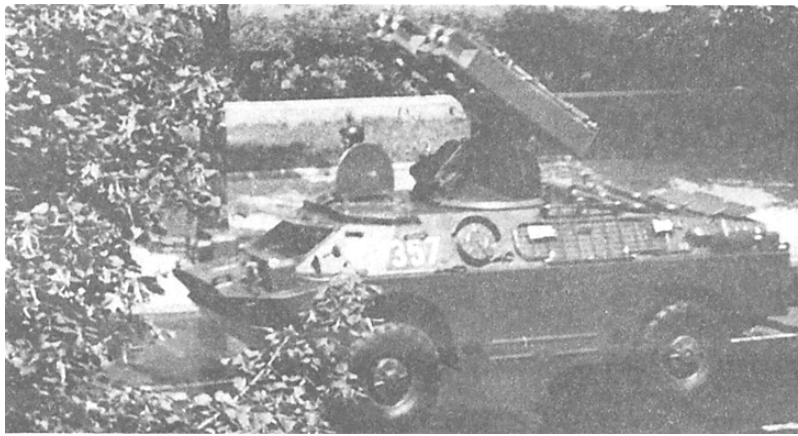

Figure 6-36.— SA-9 GASKIN missile on BRDM-2.

The systems are designed to be deployed with other antitank defenses, such as artillery and mines.

Antitank missiles (ATMs) are approximately the same size as the smaller, multiple-round, artillery rockets. ATMs may be hand carried or mounted on various types of military equipment, such as modified trucks, reconnaissance vehicles, and helicopters.

The following factors will help you identify ATM systems:

- A knowledge of what systems are likely to be found in the order of battle of a given country;
-
- A knowledge of the specific configuration of the systems; and
- Familiarity with the tactics used, especially the method of deployment.

AIR-LAUNCHED MISSILE SYSTEMS.— There are two types of air-launched guided missiles: air-to-air missiles (AAMs) and air-to-surface missiles (ASMs). AAMs are deployed on fighter aircraft; ASMs are deployed on bomber and ground attack fighter aircraft. Both AAMs and ASMs are directed toward their targets by missile guidance systems.

Air-to-Air Missiles (AAMs).— AAMs extend the capabilities of the launching aircraft in terms of speed, altitude, maneuverability, and kill ability. AAMs have internal guidance systems and fins that enable the missiles to climb and turn as they seek their targets. They are guided by either semiactive radar or infrared (IR) guidance systems. The semiactive radar approximately doubles the range of the missile compared to the IR system. However, the

launching aircraft can turn away from the target after launching an IR guided missile. Inclement weather conditions can affect the accuracy of IR guided AAMs.

Air-to-Surface Missiles (ASMs).— ASMs are deployed on bombers and fighter aircraft configured for ground attack roles. The size of the ASM is determined by the lifting and carrying capabilities of the launching aircraft.

The CIS currently has an air-launched cruise missile (ALCM), designated AS-15. The AS-15 is a small, subsonic, low-altitude cruise missile similar to the U.S. Tomahawk. The AS-15 has an estimated range of about 3,000 km.

Soviet-built Ship-launched Missile Systems

The CIS has several categories of shipborne missile systems. Some are unique to either submarines or surface ships; others are unique to a particular ship or submarine, and still others are found on both. Shipborne surface-to-surface missile systems include not only strategic, submarine-launched, ballistic missiles (SLBMs) for land targets, but also tactical cruise missiles launched by both surface ships and submarines intended primarily for use against enemy ships and submarines. CIS shipborne SAM systems are used only aboard surface ships, primarily combatants. The CIS also has a ship-to-underwater missile system and an underwater-to-underwater missile system.

CIS naval missile systems are designated the same way as their land-based missile systems, with the exception of placing an "N" between the missile type and number designation; for example, SS-N-2, SA-N-2, and SUW-N-1. In fact, many of their shipborne missile

systems are modified land systems that have been adopted for shipboard use.

As is the case of air-launched missile systems, shipboard missiles are usually kept out of sight. However, the missile launchers are generally visible, and these are what you must become familiar with when you study the various publications referenced in this section.

The following publications are a few of the many available that provide detailed information and photography regarding missile systems:

- *DIA Fact Book—Communist World Forces (U)*, DST-2660-013-YR;
- *Ballistic Missile Systems Handbook—USSR and China*, DST-1000H-249-YR;
- *World Missiles and Rockets*, DIAM 57-7, Volume XI; and
- *Naval Ships Characteristics—USSR Combatants*, DST-1210H-049-YR.

Consult the *Naval Intelligence Products Register (NIPR) (U)*, ONI-2600A-0001-YR, to find the titles of numerous other publications dealing with missile systems. Also, Jane's series of books covering ships, aircraft, and weapons systems of the world provides excellent unclassified material on various worldwide missile systems.

LIGHT TABLE MAINTENANCE AND SETUP

A well-maintained light table is essential for proper exploitation of hard-copy imagery. The procedures for the upkeep and care of your equipment will depend largely on your particular ship or station. Refer to your command's SOP for the correct guidance in this matter. You may have expertise on hand to guide you, or, if you are assigned to an afloat unit, proper procedures should be laid out in the preventive maintenance cycle. Follow this same guidance for the proper techniques used to set up your light table. You should have an active training program that will aid you in the proper operation of your equipment. The material covered in this section is general guidance for the maintenance and cleaning of light tables.

CLEANING PROCEDURES

The following is a basic set of cleaning procedures you should follow to keep your light tables in good operating condition.

Clean each light table at *least* once every 30 days of operation—more often in dirty, damp, or corrosive environments. The unit does not need lubrication.

If a light table is used frequently, clean it frequently. Dust the cabinet itself and clean the external surfaces daily. Once a week, vacuum the inside surfaces. Clean the glass illumination surfaces on the light table as often as necessary. If you fail to clean a table properly, you will allow emulsion to build up and dirt to accumulate. This will not only impair film resolution, but could damage viewing and film surfaces. The cleaning materials you will need are as follows:

- Soft, nonabrasive lens tissue;
- Distilled water;
- Sponge;
- Liquid detergent; and
- Camel hairbrush (1 1/2 inch).

In cleaning the illumination surface, be careful to keep excess liquid off transport bearings and lamps and also from underneath the glass surfaces. At the same time, wipe down the illumination surfaces and rollers.

Ball Slide Operation

Inspect the ball slides daily, and remove any foreign material to ensure continued free-slide motion. The ball-type slide used in the carriage X and Y motion and the vertical microscope mount motion mechanisms must be manually reset periodically to allow full travel in all directions. Perform the following procedures travel of the ball-type slides becomes limited in any direction.

- Check to ensure that foreign matter is not causing the problem.
- For X and Y motion limitations, force the slide to its limit.
- For microscope elevation reset, reset the upper limit by forcing the mount to its upper extreme. Reset the lower limit by applying about 10 pounds of force in the downward direction and cranking the amount to its lower limit.

For further guidance on light tables, refer to NAVAIR 00-35QP-11.

MOSAIC CONSTRUCTION

In this section, we will discuss the types of mosaics and the materials that you may use to mount the mosaics.

The photographic mosaic is constructed from two or more overlapping prints joined so that they form a single picture. Usually, vertical photographs are used, and a map-like result is obtained. However, oblique photographs may be used; in which case, the result is a panorama. The photographic mosaic has become increasingly useful in cartography, intelligence, and related fields since World War I. Large geographic areas can be represented in this manner, and cultural, as well as natural, features are shown in relative size, position, and appearance. A vast amount of detailed information of special value for intelligence purposes is represented. The simplest types of mosaics are quickly and easily assembled. These characteristics make mosaics an important and valuable device for use by the interpreter in illustrating briefings and reports.

TYPES OF MOSAICS

There are three types of photographic mosaics: *uncontrolled*, *controlled*, and *semicontrolled*, the latter being a compromise between the first two.

The uncontrolled mosaic is the most often used of the three, but is the least accurate. It is laid by matching image detail on the photographs.

The controlled mosaic is constructed of prints that have been altered by rectification. In rectification, a print is made larger or smaller by projection printing. Each frame is rectified to the same scale to compensate for aircraft movement. Controlled mosaics are used for map and chart revisions and photomaps and are constructed by cartographers.

The semicontrolled mosaic is laid using data from a topographic map known to be accurate in order to reduce final scale variation. It is more accurate than the uncontrolled mosaic, but is more difficult to make.

Uncontrolled Mosaic

The uncontrolled mosaic is probably the only type of mosaic you will be expected to construct. However, you could be assigned to a specific billet where semicontrolled mosaics, and possibly controlled

mosaics, may have to be constructed. The construction of semicontrolled mosaics is discussed later in this chapter.

PROCEDURES FOR ASSEMBLING.— Before you actually start to mount the mosaic, make a preliminary check of the prints for overlap and completeness of coverage. Do this by matching corresponding images on adjacent prints and laying them where they should go.

At this time, examine the nature and extent of distortion between adjacent prints to get a good estimate of the potential quality of the completed mosaic. Also during the preliminary check, plan the orientation of the prints to minimize double images in the most important areas of the mosaic.

Order of Mounting Prints.— The order in which prints are assembled is a principal factor in the distribution of errors. Since the errors tend to be cumulative rather than compensating, mount the prints covering the central area (or other most important area) of the mosaic first. Then, mount the adjacent prints from the same line of flight; finally, mount the prints from adjoining lines of flight. In this manner, you can relegate the largest errors to the least important areas. It is particularly important that the first print mounted be relatively distortion-free because adjoining prints in all directions are matched to it. Therefore, you should select this print and plan the general order of assembly when you do your preliminary check.

Mounting the First Print.— Place the print to be mounted first FACE UP on a smooth bench or table. Study the print to determine the part to be used for laying. Usually, you use the center part of the print because it has less distortion than the sides. You can greatly improve the appearance of the mosaic by cutting the print along the contours, along fences, across the edge of woods, and the edge of roads. After selecting the area, mark it where you wish to make the cut.

After you mark the print, cut through the emulsion of the print with the cutting tool slanted toward the center of the print. Take care to make sure that the print is not cut completely through, that only the emulsion is cut.

Tear away the edges to be discarded. In tearing away the edges, hold that portion of the print to be retained in the fingers of one hand while grasping the discard edge in the other hand. Tear the edge back and away slowly and carefully with a curling motion so that some of the paper backing under the retained part is

removed with the discarded edge. This gives the print a rough tapered, or feathered, edge.

Smooth the feathered edges with sandpaper to reduce ridges at the edge of each print in the mosaic. The first print is now ready for mounting.

There are two methods of using rubber cement to lay photographs for a mosaic: the wet-mount method and the dry-mount method. Do not confuse the latter method with the dry-mounting press.

- **Wet mounting**— As a semipermanent method, wet mounting allows you to move the photograph as you position it on the mounting board. In this method, you apply the rubber cement only to the back of the photograph that you are mounting. Then, place the photograph directly on the mounting board while the cement is still wet. This enables you to move the photograph for proper alignment and location. When the photograph is properly located, place a sheet of tissue paper over the photograph and press the photograph flat with a straight edge to squeeze out the excess cement. Once the excess cement has dried, remove it by using a cement pickup.
- **Dry mounting**— Though not completely permanent, dry mounts hold extremely well. This method of mounting requires you to position the photograph exactly in place before attaching it to the mounting board. For this method, both the back of the photograph and the mounting board are covered evenly with cement and allowed to dry. When the cement is dry, the two surfaces instantly stick to each other upon contact. Once the print is affixed to the mounting board, it cannot be worked or positioned any further.

Select an adjoining print and match the images in the area of overlap. With a grease pencil, draw a light guideline for the cut along the successive images where the best match occurs. If possible, consider the tone match as well as the image match of the prints. Avoid straight guidelines as much as possible, since straightedges are more noticeable in the finished mosaic. Smooth, irregular curves are best. Cut the emulsion along the marked guideline, tear away the discard positions, and feather the edges in the same way as you did the first print.

After you have sanded the edges, match the print to the print you previously laid. If the match is satisfactory, use a grease pencil to make three or four

lines about 1 inch in length across the match line. Make similar orientation marks around the entire print. These grease pencil marks facilitate proper positioning of the print. Proper positioning of the match edge is the most difficult step of the process. Working from the print in the center (the first print laid), lay all the prints in that flight line outward from the initial print; then proceed to an adjacent flight line.

When you reach the edges of the mosaic, trim the border prints on three sides only and the corner prints on two sides only. This allows all possible room needed for the borders.

FINISHING THE MOSAIC.— Frame the mosaic around the limit of the desired area; then, place a north arrow where it does not obscure image detail. Prepare a carefully checked bar scale marked in appropriate units. The use of the representative fraction (RF) is not satisfactory, because, in most cases, the scale is changed in reproduction. The annotations and title block information provided depend on the particular requirement of the mosaic.

The following items are shown in most mosaic title blocks:

- Security classification and downgrading/ declassification status;
- Identification of the producing organization;
- Identification of the report that the mosaic accompanies;
- Identification of the mosaic area by name, geographic coordinates, and/or target number;
- Photographic titling information, including the date, the squadron flying the mission, mission number, print numbers, altitude, camera focal length, scale of the photography, and the security classification of the photography;
- Date the mosaic was compiled; and
- Type of mosaic (uncontrolled, controlled, or semicontrolled).

Controlled Mosaics

The controlled mosaic is constructed of prints that have been altered by rectification in projection printing, aligned to plotted control points, and mounted on a stable base. In the rectified print, the displacements caused by differences in scale, tip, and tilt have been removed through projection printing. Plotting the

control points is basically done in the same way as for semicontrolled mosaics. The complexity of the process and the equipment involved is such that the construction of a controlled mosaic is not normally within the capabilities of the IS.

Semicontrolled Mosaics

Although the uncontrolled mosaic is the easiest and quickest type of mosaic to construct, its lack of control renders it of little value for accurately determining directions and distances. Controlled mosaics, on the other hand, are completely reliable for measuring distances and directions, but are not feasible for field preparation because of the extensive time and equipment necessary for their instruction.

The semicontrolled mosaic provides a reasonable compromise between the speed and ease of construction of the uncontrolled mosaic and the accuracy of the controlled mosaic. The construction of the semicontrolled mosaic provides for the localization of the print error to avoid cumulative errors and for a simplified form of overall control by the use of checkpoints over the entire area. Although exacting measurements cannot be taken from the semicontrolled mosaic, distances and directions can be obtained with enough accuracy for most operational purposes.

PROCEDURES FOR ASSEMBLING.— The photographic requirements for prints used in constructing a semicontrolled mosaic are similar to those for uncontrolled mosaic construction. Overlap for mosaic purposes should be 60 percent for successive prints with a minimum of 30-percent sidelap. By paying careful attention to quality control procedures, you can produce prints of the same average tonal quality. To assemble a semicontrolled mosaic, follow the basic steps listed below:

1. To make the prints, use single-weight glossy, air-dried paper. Treat the paper with a glycerin solution before drying the print to keep the emulsion soft and pliable.
2. Be sure the map is the latest and most accurate available. Topographic maps are preferred, since they will normally contain the largest amount of detailed information for use in selecting checkpoints. Select a map as close to the scale of the photography as possible to minimize the degree of photographic enlarging or reducing necessary to match the photography to the base map.
3. Carefully mount the base map to the mounting board. Make sure the marginal information located on the base map is either retained or that the pertinent information is reproduced in the legend block that will be prepared and affixed to the completed mosaic.
4. Lightly outline in pencil the area that you plan to use in preparing the mosaic. Then, identify the most desirable features for use as checkpoints. Mark these features in pencil, and add subsequent checkpoints after you inspect the photography, but before you assemble the mosaic. Take care to select checkpoints that you can locate easily and that have a minimum of variation in elevation, if possible. Use good maps (preferably topographic maps) of the area, because the accuracy of the finished mosaic is directly related to the accuracy of the base map.

FINISHING SEMICONTROLLED MOSAICS.

— After the photography is mounted on the base map, the mosaic requires trimming and several additions before it can be considered complete. You may either trim or mask the edges of the mosaic to present a neat, symmetrical appearance. Be sure to provide geographic coordinates for purposes of orientation, as well as for the alignment of any desired overlays. Grid systems other than geographic may be required. In such cases, clearly identify them in the margin.

Annotate pertinent or requested information on the mosaic or on overlays that are keyed to the mosaic. It is generally preferable to indicate objects or areas on the mosaic with letters or numbers and then provide a listing within the margin to identify the subjects that were lettered or numbered. Exercise care when you annotate added graphic materials to make sure that you do not obscure important details on the basic illustration. In many instances, overlays will be the preferred method of annotating mosaics, since widely varied and detailed information may be presented on a number of overlays with a minimum amount of confusion.

In the title block of the mosaic, provide at least minimum information concerning the photography used, including the date of the flight, the squadron flying the mission, the scale of the photography, the activity preparing the mosaic, and the geographic area covered. Also include a reference to the base map you used in preparing the mosaic, and the chart number, edition, and date.

As mentioned earlier in this chapter, semicontrolled mosaics provide a degree of accuracy between the uncontrolled mosaic and the controlled mosaic. Therefore, the semicontrolled mosaic can be of considerable use to operational commands where time is highly important but some degree of accuracy is necessary. The primary purpose for semicontrolled mosaics is to prepare charts for operational uses when up-to-date charts are not available. Although the majority of mosaics made for use as briefing aids will be uncontrolled, if accurate measurements of the area covered on the mosaic are required, construction of a semicontrolled mosaic is advisable. This permits the mosaic to be used for both briefing and mensuration.

MOSAIC MATERIALS

As a rule, the materials used are common to all three types of construction. Factors, such as the intended use of the mosaic, the degree of control required, and the facilities available, will influence the selection of materials.

In general, mosaics can be mounted on almost any stable material. Tempered hardboard, plywood, aluminum, and railroad board, also known as government board, are commonly used. The use made of each mosaic dictates the selection of the mounting materials. Check the mount to be sure it is large enough for the prints to be laid.

Hard surfaces, such as tempered hardboard, are frequently used as a mounting board because they are stable, inexpensive, and may be stored, destroyed, or reused, as required. Be sure to lightly sand the mount to ensure a good footing for the adhesive.

Photographic Prints

When a mosaic is constructed for intelligence use, an artistic, beautiful picture is less important than a picture that has the best possible detail. In printing aerial negatives for a mosaic map, keep in mind that the reproduction of the finest detail from each negative is the main objective.

All prints should be of the same average tonal quality. Mosaics compiled from prints of varying tones are unsatisfactory. By paying careful attention to quality control procedures, you can make good-quality prints from almost any type of aerial negative.

The paper used in making prints for mosaic laying should be single-weight glossy, air-dried. Treat the paper with a glycerin solution before drying the print to

keep the emulsion soft and pliable. Make two prints from each negative.

Cutting Tool and Sandpaper

Use a single-edge razor blade or craftsman's knife to cut lightly through the print emulsion. After you have torn off the portion to be discarded, use fine sandpaper (grade 00) to smoothly taper or "feather" the back edge of the print. A small block of wood to hold the print on while sanding is useful.

Adhesives

When speed in constructing the mosaic is paramount, use rubber cement as the adhesive. Rubber cement is versatile, easy to handle, and can be removed from almost any surface without leaving a mark.

Rubber cement should be about the consistency of honey if it is to flow properly and hold permanently. Rubber cement hardens very quickly when it is exposed to air, so keep the containers tightly capped when they are not in use. Manufacturers of rubber cement offer a thinner that can be added to thickened cement and mixed in until the consistency of the cement is right. If thinned too much, however, rubber cement will not hold well.

You can remove photographs that have been mounted with rubber cement rubber cement thinner along their edges. The thinner seeps beneath the edges and loosens the dry cement. As the edges loosen, grasp the mounted photograph and gently pull it off the mounting board while floating more thinner along the portions that remain stuck.

CAUTION

Rubber cement and cement thinner are highly flammable. Do NOT use them near an open flame; do NOT use the thinner near a lighted cigarette.

A rubber cement pickup, made of crepe latex, is useful in removing excess cement. When the pickup is rubbed gently over the dry cement, it easily picks up the cement in hard-to-get-at areas. If a pickup is not available, rub the dry cement off with your finger or with a dry ball of rubber cement.

ANNOTATING MOSAICS AND IMAGERY

Annotation is the labeling of information contained in the illustrative material itself. Annotations include numbers, outlines, and symbols. The preparation of annotations and illustrative material varies with the service and unit.

When draftsmen are not available or speed of preparation is essential, you may type or produce annotations on a Headline and paste them onto the photograph or mosaic. This type of annotation effectively contrasts with a photo background and is neat.

When you need to copy an annotated photo in order to make additional prints or a lithographic plate, you must consider several factors about the original photo. A glossy-surfaced (ferrotyped) print retains the greatest amount of detail in the copying process. Surfaces with coarser textures diffuse more light and decrease the detail that can be reproduced. Most inks do not adhere well to the glossy surface. Further, water and some other liquids destroy the gloss. Although it is possible to restore the gloss by soaking and redrying the print, this action is seldom practical.

Annotating Procedures

To produce a properly annotated illustration, use the following procedures:

1. Include complete and accurate title blocks.
2. To annotate, begin at the upper left, number across the illustration in a band, then return to the left edge, and repeat to annotate the next band. However, if a primary installation is shown, it is usually numbered 1, regardless of its location in the illustration, Number 2 will then be the initial designation as the numbering begins in the upper left.
3. Identify primary installations, using a solid line to outline them. You may place lettering and numbering within the outline if they do not obscure important details. If details will be obscured, place the annotations outside the area and connect them to the feature by a lead-in line or arrow. Annotations should contrast with the background for easier reading. If the background is dark in tone, you can add the desired white annotation by using either white ink on the print itself or opaque ink on the negative prior to printing the photograph.

4. Determine whether there are functional subdivisions within the activity. Outline these subdivisions within the main area with a broken line, and identify them with capital letters. If a subdivision lies outside (an essential part of but separated from) the main activity, use a solid outline and identify it by a capital letter. Should there be a logical breakdown within subdivisions, number each structural unit and outline it where necessary with a narrow solid line. Number such units in sequence beginning at the upper left, working across and down.

The numbering of structural units should be consecutive from 1 through the last item within that lettered subdivision. The numbering of structural units from one subdivision to the next is continuous. For example, if subdivision A in area 2 has 13 structures and subdivision B in area 2 has 16, the numbering should be consecutive from 1 through 29—2A1 through 2A13, 2B14 through 2B29.

Print the names of major land features in uppercase letters (for example, CITY) and minor land features in uppercase and lowercase letters (for example, Village). Print names of major water features in uppercase letters (for example, RIVER) and minor water features in upper and lowercase letters (for example, Seasonal Lake). You may annotate features, such as salt pans, open mines, and quarries, for recognition purposes. If such features are not well-defined, outline them with broken lines, or use the appropriate cartographic symbol.

5. Provide location and orientation information by annotating land and water features that have recognition value. Include hazards to air navigation, such as radio towers, transmission lines, chimneys, and so forth.
6. Delineate railroads, and annotate near the edge of the illustration the nearest major destination or junction of railroads, highways, and water routes. Give the distance to these points from the primary target area.
7. Some reports require the annotation of installations that are not of a strictly military nature. According to the rules of war, certain installations, such as hospitals, should not be attacked. Each should be identified and annotated.

8. Make annotations self-explanatory or key them to the legend or the text.
9. Check to see that all annotations are within the area of the photograph that is to be reproduced. Indicate any important installation falling outside the photo area with an appropriate annotation.

Faint-Print Method

An annotation method particularly adaptable to target illustrations is direct marking of a specially prepared "faint print." This faint print is produced by underexposure and full development in the photo lab. The resulting print should have very light tones—only dark enough to clearly show the outline of important objects. You, as the interpreter, make annotations on the faint print. If you make rough annotations, have a draftsman transcribe them onto a duplicate print. With the final annotations completed, copy the print to produce a single negative for duplicate photographic prints. If only a line drawing is desired for reproduction, bleach out the photographic image, leaving only the draftsman's markings.

REPRODUCTION METHODS

For both the overlay and the faint-print method, use a double-weight paper when the size is greater than 9 x 18 inches. In preparing illustrations, you are usually limited to working with negatives, photo prints, transparencies, or drawings. You select and compile the photographic materials with consideration of the final size and shape required. You can alter the size of the illustrations to meet specifications and prepare each as a single illustration, or combine them, several on the same sheet. In reproducing the finished material, you may use one of the following methods:

- Photographic printing;
- Photocopy or other reproduction methods; or
- Lithographic reproduction.

When ordering the reproduction work, you should take many factors into consideration. Some of these are as follows:

- Select standard paper sizes (where possible) for the reproduction process to be used.
- Consider carefully the point where the copy breaks over onto another sheet.

- Indicate margins and centering.
- Allow extra border for the binding edge.
- Indicate the trimming desired.
- Allow space for the key or legend.
- Indicate the classification of all material prepared for reproduction.
- Include titling information on all prints reproduced.

OVERLAYS

Overlays are routinely used by the ground forces for sending plotted positions of enemy installations from one headquarters to another. Air units, such as fighter-bomber units, often work in close coordination with ground units. Therefore, from time to time air units use or receive overlays from a ground force commander outlining a forthcoming military operation. In such cases, the overlay tells the same story pictorially that would otherwise have required a lengthy narrative description and listing of coordinates.

On the overlay, everything is already plotted for the benefit of the receiver or user. The user quickly orients the overlay to the correct map or photograph, and the desired information is immediately available. Thus, the use of an overlay is a good method of accurately transmitting military information pictorially rather than by a lengthy message.

Advantages of Using Overlays

An overlay has at least two advantages over a written message. One is additional secrecy. An overlay is transmitted by courier, whereas written messages are usually sent by mechanical means and are subject to enemy interception. The second advantage is clarity. Once placed in position on the proper map, the overlay "tells its own story" in the exact manner that the narrator wishes it to be told.

Overlays are now being produced in the CVIC through the use of computers and digital plotters. An advantage of this method of producing overlays is the short time involved. They are also extremely accurate.

Types of Overlays

Two types of overlays are generally used: intelligence and operational.

INTELLIGENCE OVERLAYS.— Intelligence overlays contain information about the enemy situation, such as disposition of forces, types of units, flak areas, location of depots, supply installations, command posts, and airfields in the areas covered by the map. This information is portrayed by the use of military symbols.

OPERATIONAL OVERLAYS.— Operational overlays contain information about the friendly situation, such as the disposition of forces, command post, supply points, and railheads. These are shown by the use of military symbols.

SUMMARY

Combat intelligence and imagery intelligence are inseparable. The degree of exploitation concerning an enemy's military activity rests with the imagery interpreter. Imagery intelligence has proven to be particularly valuable in supplying information on enemy capabilities, such as location, facilities available at that location, number of personnel, and how much and what kind of equipment he has. Imagery intelligence has no equal as an accurate and timely supplier of this type of information.

Since defenses are also an important part of an enemy's capabilities, photo surveillance is used to pinpoint and keep track of the movements of antiaircraft artillery, field artillery, surface-to-air missiles, and so on. We do not mean to imply that imagery intelligence can supply all the answers. However, by integrating and incorporating imagery interpretation reports of military activity with other intelligence, the best, and, by far, most timely, estimate of the situation can be made.

To function adequately as an interpreter in the field of military activity, you must be familiar with air and ground forces, their equipment, and installations. You must also be familiar with equipment and installations associated with naval surface and subsurface forces and merchant shipping. To become familiar with enemy or potential enemy equipment and installations, you must be aware of, and constantly make use of, the many publications that address these subjects.

Earlier, we discussed the Department of Defense (DOD) standardized procedures and specifications for forwarding, titling, and plotting aerial photography, airborne sensor imagery, and related information. Your duties as an IS may require that you perform this work, whether you are aboard ship or at a shore activity.

To be a productive Intelligence Specialist, you should have a working knowledge of photography, camera components, film types and characteristics, photographic processing, and common image defects that may appear on negatives and prints. You should also understand the cameras, equipment, and procedures used in aerial photography and the reconnaissance aircraft on which these cameras are used.

As an IS, you may have to use aerial photographs to make mosaics or construct overlays to show operational or intelligence information. You may also have to prepare graphic material that will be used by an individual in giving an intelligence briefing or making a report. Therefore, you should take every opportunity to practice preparing mosaics, annotations, and overlays.

CHAPTER 7

MENSURATION TECHNIQUES

LEARNING OBJECTIVES

Upon completing this chapter you should be able to do the following:

- *Determine the various methods for determining photographic scale.*
 - *Explain the terms associated with determining scale.*
 - *Using fractional relationships, explain the methods used for determining scale.*
 - *Compute distance measurements on photography.*
 - *Determine the heights of objects on aerial photography.*
 - *Using metric units, convert U.S. measurements and corresponding solutions to metric measurements.*
-

As we explained earlier, one of your primary duties is to serve as an imagery interpreter. One responsibility of the military image interpreter that deserves a chapter by itself is *mensuration*, or the use of mathematical formulas or soft-copy imagery software to determine dimension and scale. The determination of an accurate scale is especially important since it directly affects your ability to determine accurate measurements from aerial photography.

Two methods are generally used for determining scale and dimension: automated and direct measurement. Most commands use the automated method, taking advantage of the new technologies incorporated into soft-copy imagery exploitation software to take their measurements directly from the screen. This timesaving method is considered accurate enough to support strike and general mission planning. A few commands, however, still rely on the old proven methods of breaking out the boxwood scale, tube magnifier, and calculator to determine their measurements. Either method is acceptable within the intelligence community. Your command has the option of deciding which method is best suited for its particular mission.

Because the operating systems and software used for soft-copy exploitation are vast and varied, not to

mention continually subject to change and upgrades, it would not be feasible for us to go into detail on the step-by-step procedures of these systems. Therefore, we will let you consult your command's SOP or contact the training petty officer for the proper procedures to use in operating these systems. We will, however, provide you with formulas and information on how they are used. This is considered to be a "lost skill" among today's Intelligence Specialists, a skill we dare not take for granted. In the following paragraphs, we will show the basic equipment and formulas required to maintain a working knowledge of mensuration techniques. Although the techniques apply to both maps and photographs, we will refer only to photographs in our discussion.

SCALE DETERMINATION

Recall the discussion from chapter 5 concerning the representative fraction for maps and charts. The same concept applies to photographs. Since the representative fraction is the "heart" of scale determination, we will review it here and show how it applies to photographs.

The scale of a photograph is the relationship between a distance on the photograph and the same horizontal distance on the ground. The result is

expressed as a fraction. It is customary to reduce the numerator of this fraction to unity by dividing both numerator and denominator by the numerator. After the numerator is reduced to unity, a fraction, such as 1/25,000 or 1/50,000, results. This fraction and the relationship that it represents is called the *representative fraction (RF)*.

The RF is normally referred to as the scale of a photograph and is the symbol indicating that one unit on the photograph is equivalent to a given number of the same units on the ground. If, for example, the scale of the photograph is 1/25,000, then one unit on the photograph is equivalent to 25,000 of the same units on the ground. This relationship is true regardless of the unit of measurement being used. The denominator (or reciprocal) of the scale is the ground equivalent or scale factor of the photograph or map. This denominator is abbreviated PSR (photo scale reciprocal) when it is applied to a vertical photograph and MSR (map scale reciprocal) when it is applied to a map.

If the photograph has a scale of 1/63,360, the same relationship may be expressed in words and figures by saying:

- 1 foot on the photo equals 63,360 feet on the ground or 1 foot equals 63,360 feet;
- 1 inch equals 5,280 feet;
- 1 inch equals 1 statute mile; and
- 1 inch equals 63,360 inches.

If desirable, the scale relationship may also be presented graphically in the form of a bar scale.

As you progress through this chapter and become aware of the various methods of determining scale, you will soon learn that, to determine scale, you must make distance measurements. If these measurements are not accurate, the scale will not be accurate.

Three factors that affect the accuracy of measurements are

- the accuracy of the measuring device;
- the quality of the image; and
- the human element.

Regardless of the accuracy of the measuring device, the final result is governed by the skill of the person making the measurement.

A knowledge of the capabilities and limitations of the different measuring devices is necessary so that you can select the device that is best suited for the job at hand.

There are no set ties for selecting the proper measuring device; each has certain advantages for a particular operation. Make the selection based on the type of work to be done and your skill level.

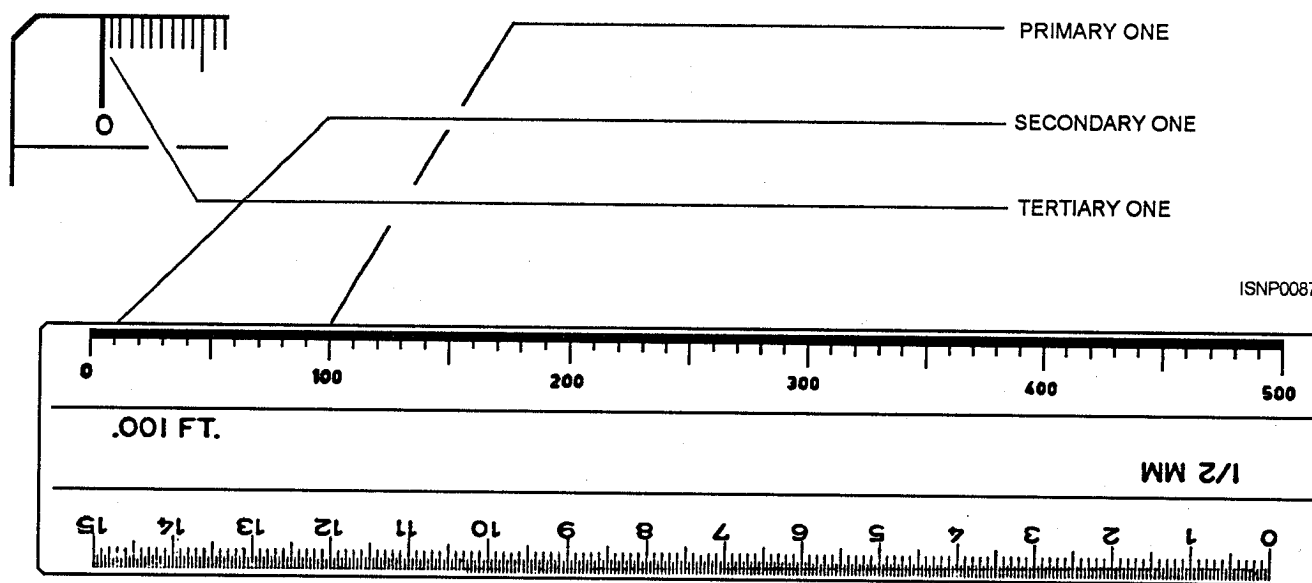

Figure 7-1.—Numbers on a boxwood scale.

MEASURING DEVICES

The instruments you will use most often to make measurements on vertical photography are classified as either linear or height-finding devices.

We will describe the instruments used in making height-finding measurements later on in this chapter.

Boxwood Scale

The boxwood scale (figure 7-1) is one linear-measuring device used to make measurements on imagery, maps, and charts. Boxwood scales are made in various lengths, but the most common lengths are 6 and 12 inches.

One side of the boxwood scale is used to measure distances in one-thousandths (0.001) of a foot or two-thousandths (0.002) of a foot, depending upon the particular boxwood scale you use. You must always read the scales as accurately as possible. Most photographic images are measured to the nearest five ten-thousandths (0.0005) of a foot. The numbers on the

boxwood scale are broken down into primary, secondary, and tertiary divisions.

Notice in figure 7-1 that each primary number has 10 major dividing points. Each of these lines is called a *secondary number*. The 10 lines between each secondary number are called *tertiary lines*. Each tertiary line is equal to one-thousandth (0.001) of a foot.

In some cases, we must read numbers smaller than thousandths. In these situations, we imagine 10 numbers between each tertiary line, representing ten-thousandths, and we interpolate, or estimate, where a ten-thousandths number should lie between the two lines. A number between the tertiary lines is read 0.0001, 0.0005, or 0.0009. All three of these numbers are located between "0" and the first tertiary line.

The other side of the boxwood scale is divided into one-half millimeter graduations. Cartographers (mapmakers) use this scale extensively, and some phases of photogrammetry may require that measurements be read in millimeters. Figure 7-2 provides sample readings of both sides of the boxwood scale.

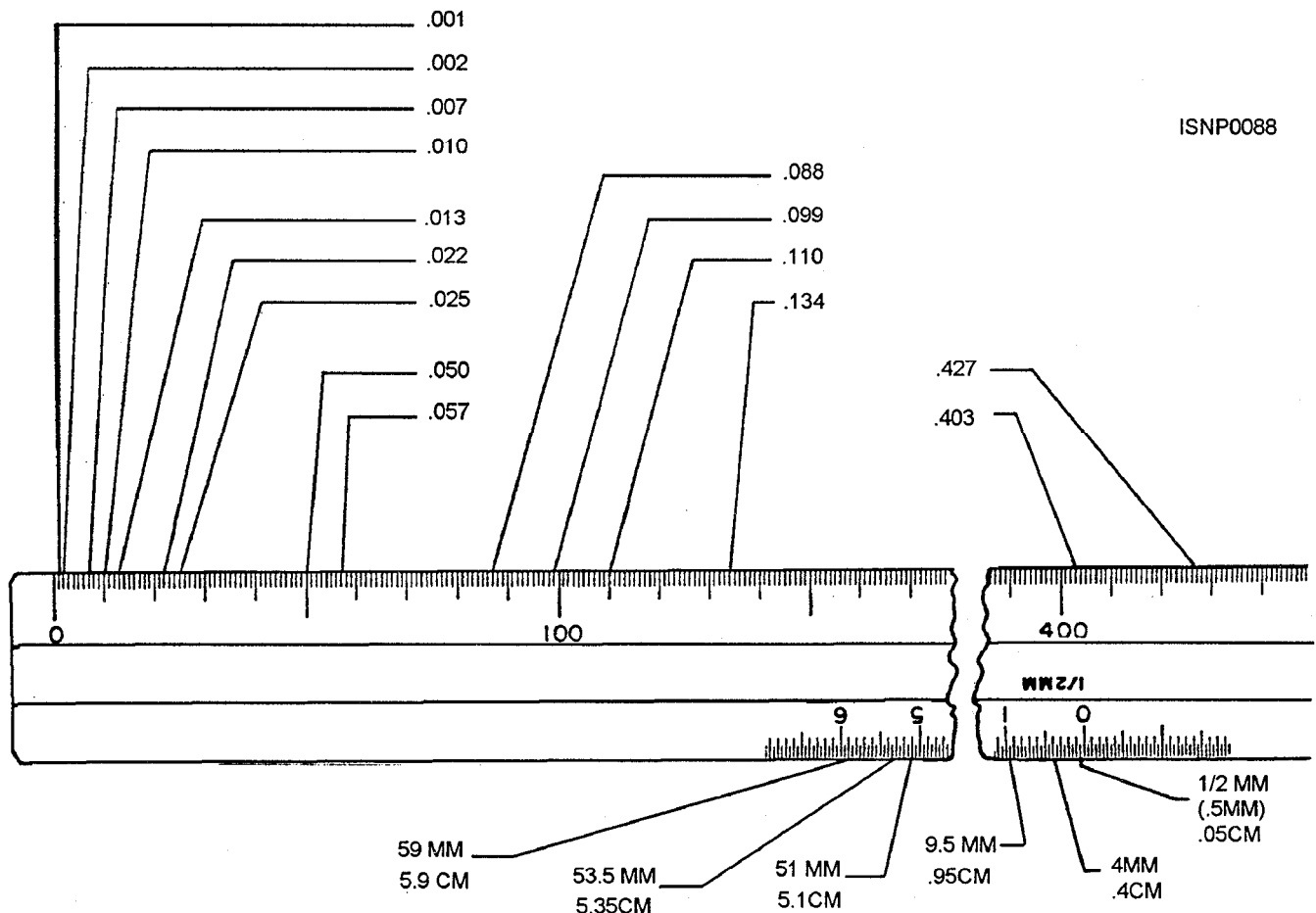

Figure 7-2.—Example boxwood scale readings.

Tube Magnifier

The tube magnifier (figure 7-3) is another linear-measuring device you will use to make measurements. This instrument is a simple magnifying glass set in a tubular frame, with the eyepiece at the upper end and a graduated scale at the base. The scales are interchangeable, with graduations indicated in thousandths of a foot, in millimeters, or both. Some of the newer tube magnifiers have graduations in ten-thousandths of a foot. The system of scales etched on the lens of an optical instrument is called a *reticle*. Scale lenses that have a miniature protractor for measuring angles, such as the sweepback of aircraft wings, are also available.

Light Table Optics

Since you will often work with roll film positives on a light table, you may decide to use a measuring device along with the light table optics. The optics are mounted on the stereo zoom base of the light table. Take care when using this method; always wear photo handling gloves and be careful not to scratch the film.

SCALE DETERMINATION TERMS

A number of standard terms are used in the scale determination process, and each term is identified by a standard abbreviation. It is important that you understand these terms and their associated abbreviations, because you will use the abbreviations in all formulas involving scale and distance determinations. The standard terms and their associated abbreviations and definitions are as follows:

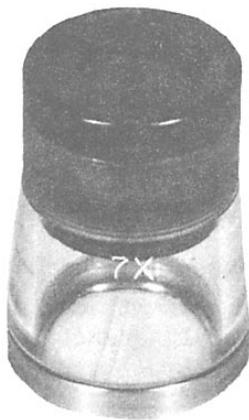

Figure 7-3.—Tube magnifier.

- **Photo scale reciprocal (PSR)**—In a photo scale of 1:10,000, 10,000 is the photo scale reciprocal, or ground equivalent, of the photograph.
- **Map scale reciprocal (MSR)**—In a map scale of 1:250,000, 250,000 is the map scale reciprocal, or ground equivalent, of the map.
- **Actual ground distance (D)**—The actual ground dimensions of an object, or the actual distance on the ground between two points.
- **Altitude above ground level (Ht)**—The actual altitude of the aircraft above the mean terrain elevation; absolute altitude.
- **Barometric altitude (BA)**—Altitude above mean sea level; the actual altitude of the aircraft above mean sea level.
- **Nadir (N)**—The point on the ground directly below the camera lens at the time of exposure.
- **Ground elevation (E)**—The actual terrain elevation above mean sea level.
- **Photo distance (pd)**—The actual measurements of an object on the photograph, or the measurements between two points on the photograph. (pd is also referred to as measured object displacement, or image displacement, on the photograph.)
- **Map distance (md)**—The actual measurements of an object on the map, or the measurement between two points on the map.
- **Focal length (f)**—The focal length of the camera lens used to obtain the photography. Focal length is normally expressed in inches but may also be expressed in millimeters.

We will use these standard abbreviations throughout our discussion in the next section on the methods of determining scale. For a consolidated list of all the formulas used in this chapter, see table 7-1,

METHODS OF DETERMINING SCALE

As we mentioned earlier, scale is the relationship between a distance on the photograph and the same distance on the ground. Therefore, you can determine the scale on a photograph using the following fractional relationships:

Table 7-1.—Mensuration Formulas

<u>PSR Formulas</u>	<u>Variations</u>	
Recognition method $PSR = \frac{D}{pd}$	$D = pd \times PSR$	$pd = \frac{D}{PSR}$
Photo/map comparison $PSR = \frac{md(MSR)}{pd}$	$pd = \frac{md(MSR)}{PSR}$	$\frac{md(PSR)}{MSR}$
<u>Determining actual ground size</u> (length, width, diameter, distance)		
$D = pd \times PSR$		
$D = md \times MSR$		
<u>Height formulas</u>		
Single Photo Displacement:		
$Hu = \frac{pd(Ht)}{r}$		
Shadow Proportion: $Hu = \frac{dsu(Hk)}{dsk}$		

$$\frac{\text{Distance on photo}}{\text{Distance on ground}} = \text{Scale of photo,}$$

or

$$\frac{\text{Distance on ground}}{\text{Distance on photo (PSR)}} = \frac{\text{Denominator photo}}{\text{of scale}}$$

By using either of these relationships, you have two means of determining the scale of a photograph. These are (1) the *recognition* and measurement of objects of known size appearing on the photograph and (2) the direct *comparison* of a photograph and a map.

RECOGNITION METHOD

In photographs showing man-made objects, it is frequently possible to find at least one object that can be positively identified and whose dimensions are either accurately known or can be determined. For example, football fields, tennis courts, and baseball diamonds are easy to identify on photographs.

On photographs of airfields, identifiable aircraft are almost always visible. When these aircraft can be positively identified, their known wingspan dimensions

can be used to compute photographic scale. For example, let's assume that a photograph of an airfield shows two aircraft that are positively identified as a Tu-16 Badger C with a wingspan of 108 feet and a MiG-23 with a wingspan of 46 feet. The wingspans of the two aircraft on the photograph are 0.0181 foot and 0.0077 foot, respectively. The scale of this photograph, using the photo image measurement of the Tu-16 Badger C wingspan, is determined as follows:

$$\text{Scale} = \frac{1}{PSR} = \frac{\text{Photo distance}}{\text{Ground distance}} = \frac{pd}{D} = \frac{0.0181}{108}$$

or

$$PSR = \frac{\text{Ground distance}}{\text{Photo distance}} = \frac{D}{pd} = \frac{108}{0.0181} = 5966$$

Therefore,

$$\text{Scale of the photograph} = \frac{1}{5966}$$

We can check this value by using the information available on the MiG-23 wingspan.

$$\text{Scale} \frac{1}{\text{PSR}} = \frac{\text{Photo distance}}{\text{Ground distance}} = \frac{pd}{D} = \frac{0.0063}{46}$$

$$\frac{1}{\text{PSR}} = \frac{1}{5974}$$

As you can see, the two scale values are not identical but are within an acceptable error tolerance range. Measurements made on this photograph and applied to a PSR of 5970 would result in acceptable ground dimensions or distances.

COMPARISON METHOD

Determining scale would be a simple task if you were always able to compare distances on a photograph directly with the corresponding horizontal distances over the ground. However, the required ground distances are not always known. Therefore, you must frequently compare photo measurements against map measurements of known scale.

As we discussed in chapter 5 of this manual, a map measurement multiplied by the map scale reciprocal (MSR) will provide the actual ground distance for that measurement. This same procedure is used to measure a photograph. You simply multiply the photo measurement by the photo scale reciprocal (PSR) to determine the actual ground distance for that measurement. If you measure an object or a distance on a photograph and then measure the same object or distance on a map of known scale, you can establish a ratio that will provide the PSR. This is possible because the ratio between the map measurement and the photo measurement is in proportion to the ratio between the MSR and the PSR. This ratio can be expressed in a formula using standard abbreviations as follows:

$$\text{MSR} \times \text{md} = \text{PSR} \times \text{pd}$$

or, to solve for PSR

$$\text{PSR} = \frac{\text{MSR} \times \text{md}}{\text{pd}}$$

Example: Two road intersections are determined to be 0.500 foot apart on a vertical photograph. The same two intersections are 0.250 foot apart on a map whose scale is 1:50,000. The scale of the photograph is required.

$$\text{PSR} = \frac{\text{MSR} \times \text{md}}{\text{pd}} = \frac{50,000 \times 0.250}{0.500} = 25,000$$

Therefore, the scale of the photograph is 1:25,000.

In this example, we used two points and only one distance. To minimize errors, you should check this scale with an additional computation. The most desirable situation involves using three points that can be identified on both the map and the photograph. As long as these three points are not on a straight line, you can measure the three distances on both the map and photograph. From these measurements, you can then check the value for the unknown scale.

Many times, the scale may vary slightly on the same photograph. When this occurs, you should determine the average scale using the following procedures:

1. Orient the photograph to the map.
2. Locate the photograph accurately on the map, determining the extent of coverage.
3. Select three points to be measured. Ideally, these points should be at about the same elevation on the ground, approximately an equal distance from the center of the photograph. The lines connecting the points should pass through or near the center of the photograph.
4. Locate accurately on the map the same points that you chose on the photograph.
5. Measure the distances between the points on the photograph and the corresponding points on the map.
6. Substitute the measurements for the proper elements in the above comparison-method formula.
7. Complete the arithmetic functions to determine the scale for each pair of points.
8. Determine the average of the three scales by adding the denominators and dividing by 3.

The comparison method of determining scale is the most accurate method when a reliable map is available. Many times, however, a map or chart of the same area as that of the photograph may not be available. Even if one is available, the natural and man-made features may have changed since the map was made.

DISTANCE MEASUREMENTS

The primary reason for computing the scale of a photograph is to use that scale in determining the actual ground sizes of objects in the photograph. To find the actual ground length represented by any image,

multiply the measured length of the image (pd) by the scale factor or photo scale reciprocal (PSR),

$$D = pd \times PSR.$$

Example: On a photograph that has a scale of 1:13,500, the image of a ship measures 0.040 foot. By substituting these figures in the equation, you will find that the ship is actually 540 feet long.

$$D = 0.040' \times 13,500 = 540 \text{ feet}$$

Since the PSR has no unit value, D is expressed in whatever units that were used in measuring the pd.

Use of the PSR in the manner just explained is one of the most frequent and important computations in photo interpretation. The actual sizes of many objects must be included in photo intelligence reports. Also, the sizes of objects must often be determined before accurate identification and intelligent interpretation can be made of them.

The formula for ground distance determination is also useful when arranged in another form:

$$pd = \frac{D}{PSR}$$

Example: On a 1:5,000 scale photograph of a navy yard, you want to draw a graphic scale line to represent a ground distance of 1,000 feet. Using the equation, you determine the line to be 0.2 foot long.

$$pd = \frac{1,000}{5,000} = 0.2$$

You can now divide the graphic scale line into 10 equal parts, each division representing 100 feet on the ground. This enables you to quickly determine the lengths of the various vessels in the yard by using dividers and comparing the lengths of the vessels to the graphic scale line.

HEIGHT DETERMINATION

When extracting intelligence from aerial photographs, you may find it necessary to determine the heights of objects above ground level or the difference in elevation between two points on the ground.

HEIGHT DETERMINATION TERMS

Just as we use standard terms and abbreviations to determine scale, we also use standard terms and abbreviations to determine height. We will use the standard abbreviations listed below to construct formulas to use in solving height determination problems.

- **Altitude above ground level (Ht)**— The actual altitude of the aircraft above the mean terrain elevation; absolute altitude.
- **Unknown height (Hu)**— The unknown height of an object imaged on the photograph.
- **Known height (Hk)**— The known height of an object imaged on the photograph.
- **Measured object displacement (pd)**— The distance from the bottom to the top of an object, taken from the photograph.
- **Radial distance (r)**— Radial distance from the principal point (normally the center) of the photograph to the top of the object being measured.
- **Distance shadow unknown (dsu)**— The image measurement of the shadow length of an object of unknown height.
- **Distance shadow known (dsk)**— The image measurement of the shadow length of an object of known height.

RELIEF DISPLACEMENT METHOD

The point on the ground directly below the camera lens at the time of the exposure is called nadir, and the image of this point on the photograph is called *the photo nadir*. The photo nadir is the intersection of the vertical axis passing through the rear nodal point of the lens and the plane of the photo. On a photograph, all objects having height and not located at the nadir appear to lean or tilt away from the nadir point. This apparent tilt is called *parallax displacement*, or *relief displacement*, which is always radial from the nadir. The taller the object and the farther it is from the nadir

point, the greater is the displacement. To better understand this, refer to figure 7-4.

If the photograph is truly vertical (not affected by lean or tilt), the principal point and the nadir point will coincide. The principal point is the intersection of the fiducial axes. The fiducial axes are the horizontal and vertical lines drawn through the midpoints of the sides of the photograph (see figure 7-4.)

A vertical object on a photograph that appears to lean or tilt away from the nadir point is said to have *top displacement*. The fact that the top of the object is displaced means that its image includes a shortened view of its side. The measurement, *pd*, of this view is the displacement of the object. The height of the object whose image is displaced can be found by making two measurements on the photograph and applying the following formula:

$$Hu = \frac{pd \times Ht}{r}$$

The first step in this procedure is to locate the principal point of the photograph. This is accomplished by connecting opposite fiducial marks (figure 7-4). The principal point is located at the point where lines drawn through the fiducial marks intersect. (As we mentioned earlier, this applies only to true vertical photographs; measurements are actually made relative to nadir, which will not be at P if there is any tilt.)

The next step is to measure the radial distance (*r*) from the principal point of the photograph to the top of the object being measured. This is done by measuring the photo distance from the principal point to the top of the object being measured.

The last element required to complete this procedure is the image displacement (*pd*). This is

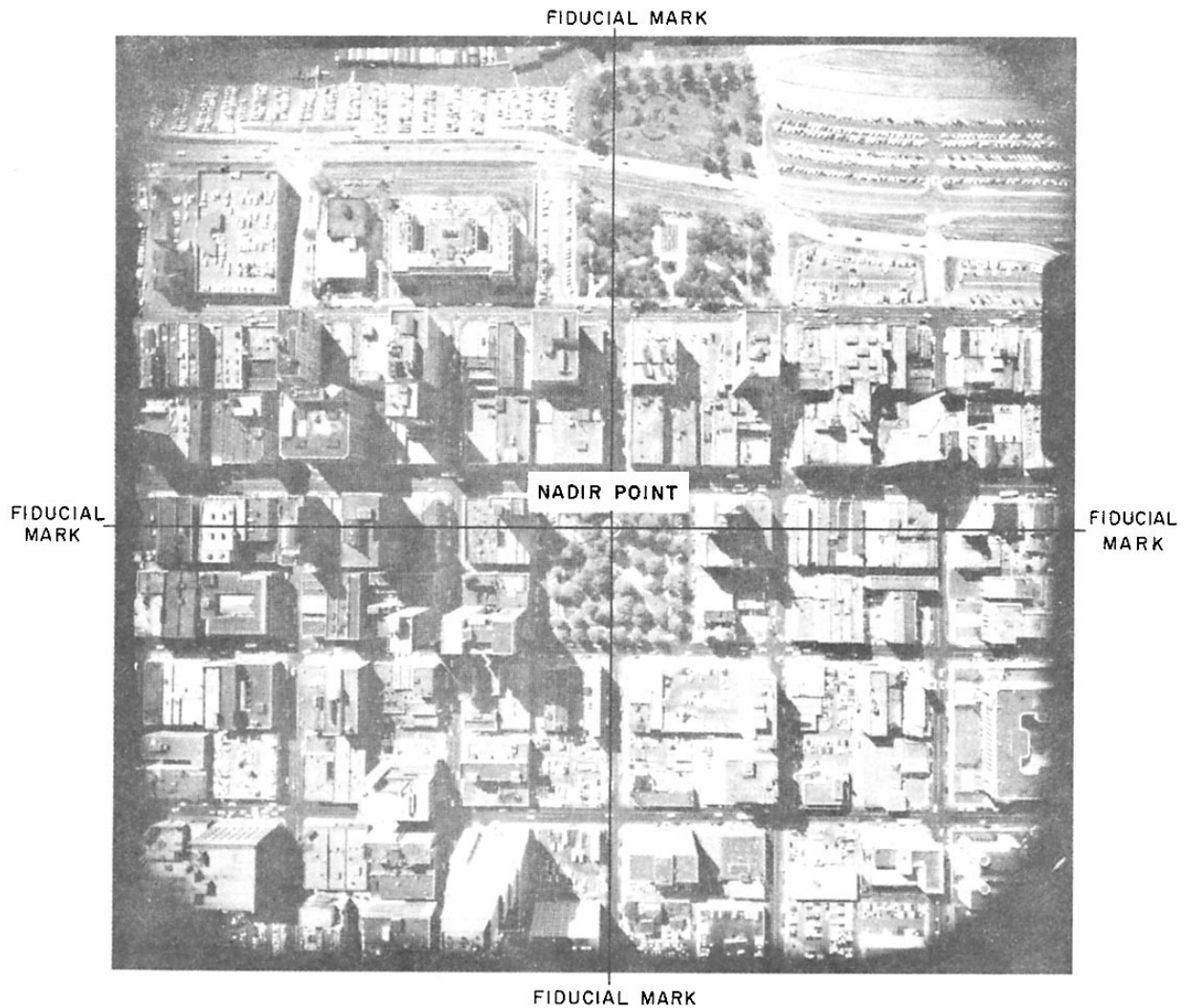

Figure 7-4.—Relief displacement.

simply the photo image measurement, bottom to top, of the object being measured.

Example: A smokestack appears on a vertical aerial photograph that was exposed from an altitude of 5,000 feet above the mean terrain (Ht). On the photograph, the top of the smokestack is 0.159 foot from the principal point of the photograph(r) and the image of the smokestack measures 0.007 foot from bottom to top. By applying the following formula:

$$Hu = \frac{pd \times Ht}{r} = \frac{0.007 \times 5,000}{0.159}$$

you will find that the smokestack is approximately 220 feet high.

Photo measurements should be made to an accuracy of 0.001 foot. The most critical measurement is the determination of the value for the image height, pd. A 0.001-foot variation in this dimension can alter the computed height by many feet. Consequently, you should use extreme care when making photo image measurements.

Height determination from relief displacement is most effective with images located in the outer area of the photograph. If the image is close to the nadir point, the perspective shows only a small amount of displacement. Since there is a limit to the accuracy of the measuring technique used, greater error results for images close to the nadir than for those located 1 or 2 inches away from the nadir point.

The accuracy of heights obtained by the relief displacement method is limited by the accuracy of scaling and the requirement that the photograph must be a vertical. If the photograph is tilted from the vertical, computed heights will be in error. Label as approximations any heights that you compute using the relief displacement method.

OBTAINING HEIGHT FROM SHADOWS

Shadows on vertical aerial photography are extremely useful in obtaining height information. On a vertical photograph, there is a direct relationship between the height of an object and the length of its shadow. By identifying an object of known height and comparing its shadow with the shadow of objects of unknown heights, you can determine the unknown heights. However, use caution in selecting and measuring shadows for comparison. The shadows must fall on reasonably level ground surfaces and must be measured along the part related to height (not length) of

the object. For any relatively small area of level ground, shadow length is directly proportional to object height. The sun is so far away that its rays are considered to be parallel. These rays make the same angle on level ground, since, for small areas, the curvature of the Earth (which would make the angle change) is negligible. This means that for every foot of height, an object casts a shadow of a particular length.

For example, a 20-foot tower will cast a shadow that is twice as long as one cast by a 10-foot tower. Similarly, a shadow 20 feet long must be cast by a tower twice as high as one for which the shadow is 10 feet long. If the shadow images of two objects on a photograph are in a certain ratio to one another, the photo images of those two objects are in that same ratio with respect to height. This tells us that if we know the height of one object on the photograph and can measure the shadow of that object, we can measure the shadow length of any other object on that photograph and determine the object's height. Thus, the formula for computing height by the shadow comparison method is

$$\frac{Hk}{dsk} = \frac{Hu}{dsu}$$

Example: A tower that is known to be 40 feet high is imaged on a vertical aerial photograph. The photo image measurement of the shadow cast by this tower is 0.030 foot. The shadow that is cast by a second tower of unknown height has a photo image measurement of 0.045 foot. The height of the second tower is required,

$$\frac{Hk}{dsk} = \frac{Hu}{dsu} \text{ or } Hu = \frac{Hk \times dsu}{dsk} = \frac{40 \times 0.045}{0.030} = 60 \text{ feet.}$$

Therefore, the second tower is 60 feet high.

The Hk/dsk ratio also can be used as a multiplier which, when applied to the shadow image length of any object in a particular photograph, will give the height of that object. Since photo measurements are normally made in thousandths of a foot, multiply the shadow image measurement by 1,000, which produces a value called the *shadow factor*. This factor is the value (in feet) of object height that is represented by each 0.001 foot of shadow length on the photograph. Using the figures from the above example, compute the shadow factor as follows:

$$\text{Shadow factor} = \frac{Hk}{dsk \times 1,000} \text{ or } \frac{40}{0.030 \times 1,000} = \frac{4}{3} \text{ or } 1.333$$

Any photo shadow length expressed in thousandths of a foot, when multiplied by 1,333, gives that object

height in feet. To continue with the figures from the original example, the shadow image measurement of the unknown object height was 0.045 of a foot. Thus:

$$Hu = 1.333 \times 45 = 60 \text{ feet}$$

The shadow comparison method of height determination can be used only when an object of known height appears on the photograph.

ELECTRONIC CALCULATORS

You will encounter a variety of electronic calculators at various intelligence installations. These calculators range in size and complexity from limited, programmable desktop models to the small, individualized, miniature electronic models. Whatever type of calculator is available, you should become familiar with its capabilities and operation. If electronic calculators are available, you should use them because of their speed and accuracy in solving computations.

THE METRIC SYSTEM

Although the foot is the basic unit of measurement generally used in imagery interpretation, you must frequently convert such measurements and corresponding solutions to the metric system. More and more often, dimensions of objects on photographs, when included in official reports, must be expressed in both U.S. and metric units of measurement.

The metric system is a decimal system of weights and measures in which the gram (.0022046 pound), the meter (39.37 inches), and the liter (61.025 cubic inches) are the basic units of weight, length, and volume, respectively. Most names for the various other units in this system are formed by adding the following prefixes to the three basic terms:

Kilo (one thousand), as 1 kilometer = 1,000 meters.

Hecto (one hundred), as 1 hectometer = 100 meters.

Deca (ten), as 1 decameter = 10 meters.

Deci (one tenth), as 1 decimeter = 1/10 meter.

Centi (one hundredth), as 1 centimeter = 1/100 meter.

Muilli (one thousandth), as 1 millimeter = 1/1000 meter.

Other prefixes sometimes used are myria (ten thousand), mega (one million), and micro (one-millionth).

As we mentioned earlier, the majority of measurements that you will be concerned with are primarily feet (or decimal parts of a foot), yards, and miles. However, you may occasionally need to convert your measurements to metric values. Therefore, we are providing the following conversion factors:

Feet to meters— Multiply feet by 0.3048.

Yards to meter— Multiply yards by 0.9144.

Miles (nautical) to kilometer— Multiply nautical miles by 1853.2.

Miles (statute) to kilometers— Multiply statute miles by 1609.3.

Meters to feet— Multiply meters by 3.281.

Meters to yards— Multiply meters by 1.0936.

Kilometers to nautical miles— Multiply kilometers by 0.5396.

Kilometers to statute miles— Multiply kilometers by 0.62137.

A complete table of metric and other conversion information is contained in appendix IV of this training manual.

SUMMARY

In this chapter, we explained the importance of determining photographic scale in image interpretation. Knowing the correct size of an image often leads to identification of an otherwise unidentifiable object. We also discussed commonly used measuring devices and the necessity of taking accurate measurements. Much of the chapter was devoted to the various methods of determining scale. We discussed using new software technologies associated with soft-copy imagery and the importance of keeping up with the basic noncomputer methods.

CHAPTER 8

AUTOMATED INFORMATION SYSTEMS (AIS) FUNDAMENTALS

LEARNING OBJECTIVES

Upon completing this chapter you should be able to do the following:

- *Describe basic terminology associated with personal computers.*
 - *Identify and describe the basic input/output devices and accessories associated with personal computers.*
 - *Explain the basic procedures associated with setting up and operating personal computers.*
 - *Explain the basic procedures associated with word processing software, spreadsheet software, and database software.*
 - *Identify and explain the use of basic utilities programs associated with personal computers.*
-

As an IS, you will be exposed to many different automated information systems (AISs). The basic unit used to support these systems is the microcomputer or, for the purposes of this chapter, “the computer.” Microcomputers are indeed everywhere. They stand alone, communicate with minicomputers and mainframes, and communicate with other computers through local area networks, or LANs. This communication is accomplished through software designed to make the computer system function. Operating system software enables you to install, select, and run a variety of programs.

An IS will generally be a computer *user*, not a computer *specialist*. You are an end user in a functional area where specific computer processing is required. As a user, you will need to be familiar with two general areas: hardware and software.

- **Hardware**— The computer, the hard disks and floppies, the monitor, the keyboard, and the printer;

- **Software**— The operating system, the communication software, and the applications programs.

You may need help to configure (setup) the system, install the operating system and/or applications program, and troubleshoot problems. If so, seek help from someone in your area who is knowledgeable in solving such problems.

COMING TO GRIPS WITH THE HARDWARE

Computers come in many shapes and sizes with a variety of capabilities. A computer can be designed to operate in a **stand-alone** configuration or as a component, an intelligent terminal, a controller for a complex **local area network (LAN)** or a large **distributed system**. In this chapter, we will focus our attention on desktop computers that operate as stand-alone units. Most stand-alone desktop computer

systems contain at least five hardware components (figure 8-1). They are as follows:

- **The computer unit** (also called the CPU), which normally houses the computer microprocessor chip and other hardware components and secondary storage devices;
- **Secondary storage devices** (floppy-disk drives, hard-disk drives, and magnetic tape units), housed either in the computer cabinet or in a separate cabinet;
- **A monitor** (standard output device);
- **A keyboard** (standard input device); and
- **A printer** (an additional output device—for hard copy).

THE COMPUTER OR CENTRAL PROCESSING UNIT (CPU)

The computer or CPU (figure 8-2) is the main part, or heart, of the total computer system. Inside this unit all data are processed, arithmetic and logic functions are performed, and control is maintained over the system. If you were to remove the outer cover from this unit, you would see a power supply and some combination of floppy-disk drives and hard-disk drives. You would also see several circuit boards (also referred to as “cards”). The largest of these boards is known as the *system board* or, more commonly, the *motherboard*. On the motherboard, you will find a large integrated circuit chip, the *microprocessor*. The microprocessor is the “brain” of the computer, where all the data processing takes place.

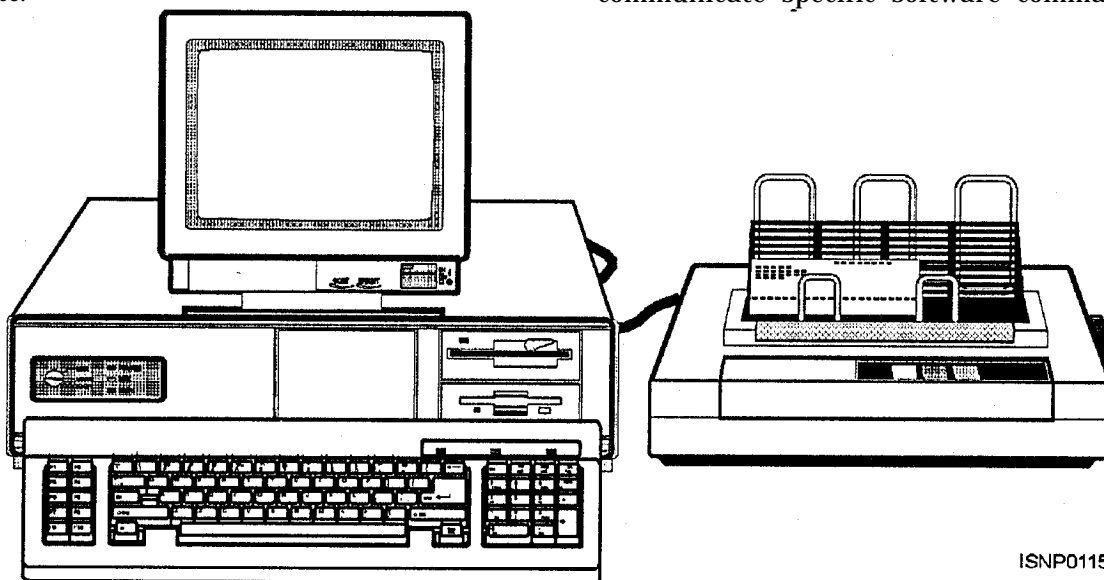

Figure 8-1.—Computer hardware.

The version of the microprocessor gives the computer its numerical typed designation, such as “286,” “386,” “486,” and so on. Some of the smaller boards work in conjunction with the microprocessor, while others are used to control peripheral (exterior) devices. These boards provide the flexibility to add a variety of capabilities to a basic system. Certain boards, such as the motherboard, are required. Others might simply be added to control a light pen or mouse device, or to handle a communications interface.

INPUT/OUTPUT DEVICES AND ACCESSORIES

Although a computer is a powerful device, it cannot do anything for us unless it can receive information from us and give information back to us. Input/output devices solve this problem by allowing us to communicate with the computer. These devices include the keyboard, the monitor, disk drives, and the printer. We will look at each of these devices in the following sections along with some of the more common accessories found on computers, such as surge protectors, parallel-to-serial converters and vice versa, null modems, cables, and switches used for sharing hardware.

Keyboard

Of all the components that makeup a computer, you will become most familiar with the keyboard (figure 8-3). It will probably be your primary means for inputting programs and data into the computer.

Keyboards come in many shapes and sizes, have different numbers and arrangements of keys, differ in respect to touch, and have special keys to allow you to communicate specific software commands. Most

ISNP0115

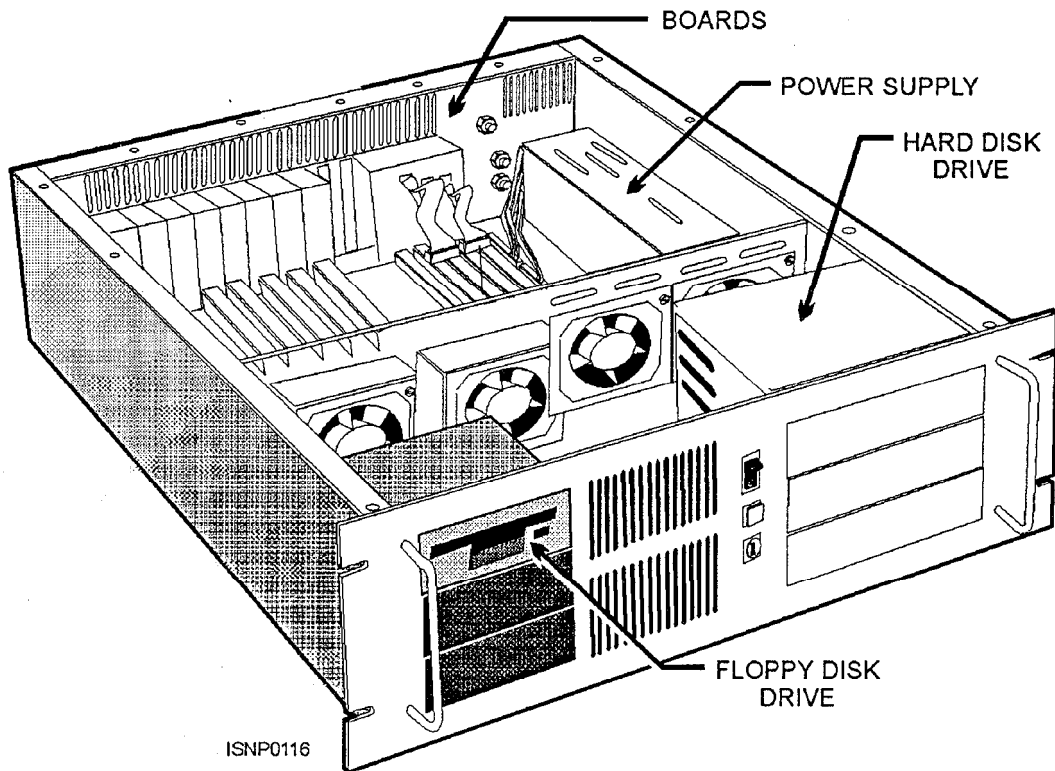

Figure 8-2.—Central processing unit (CPU).

manufacturers have designed their keyboards as separate devices so you can place them wherever it is convenient (even in your lap). A few manufacturers, however, have designed their keyboards into the display/monitor device or CPU.

The important things you need to know about keyboards are the types of keys and the function and placement of each. All keyboards have the alphabetic characters (upper and lower case), numbers, and some special characters. In addition, keyboards have special function keys and control keys that are defined by the operating system or the program. We will briefly describe an example keyboard and explain some of the more common keys you are likely to use.

LETTERS, NUMBERS, AND SPECIAL CHARACTER KEYS.— These are basically the same letter, number, and special character keys you expect to find on a standard typewriter, although their arrangement may vary. The QWERTY keyboard shown in figure 8-3 has the same format as the conventional typewriter.

CONTROL KEYS.— These keys are also basically the same keys you will find on a standard typewriter, with a few additions. Their arrangement may vary slightly from one keyboard to another, but you will usually find them somewhere on every keyboard. Follow this description on figure 8-3. Beginning in the top left-hand corner, you see the ESC (escape) key, TAB

key, CTRL (control) key, SHIFT key, and ALT (alternate) key. To their immediate right are the SPACE BAR and the CAPS LOCK key. On the right-hand side of the keyboard are the BACK SPACE key and the ENTER/RETURN key. These keys usually perform the same functions from program to program, but some may change functions. Check the user's manual for your particular software to be sure.

SPECIAL FUNCTION KEYS.— These keys are used to communicate special functions to the operating system or the applications software. The meaning of each key, such as “format,” “indent,” “print,” and so on, is defined by the particular software. This simplifies tasks that might otherwise require several keystrokes. These keys can also be used with other keys to increase

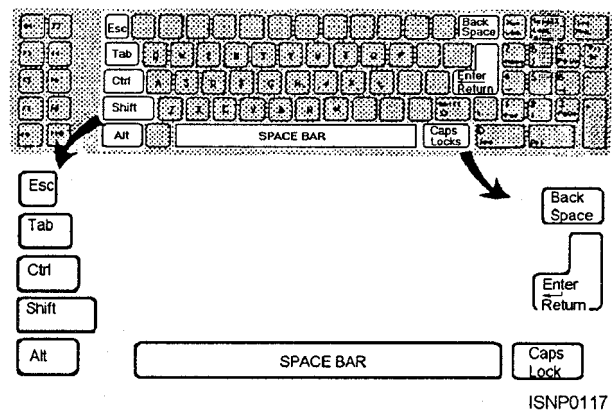

Figure 8-3.—Computer keyboard.

the number of functions associated with a program. Located either across the top edge or on the far left side of the keyboard (as in figure 8-3), are 10 special function keys labeled F1 through F10. The number of these function keys may also vary. On the right side of the keyboard is another group of special function keys. These include a 10 key (0-9) numeric keypad and the cursor control keys. also, beginning on the top row at the right, you will see the NUM (numeric) LOCK key, SCROLL LOCK/BREAK key, and SYS REQ (system request) key. Directly below these is the PRT SC (print, screen) key. Located on the bottom right-hand side of the keyboard are the INS (insert) and DEL (delete) keys. As with the control keys, these keys may be assigned different functions, depending on the program or software.

Monitor

The monitor provides a display like a television viewing screen and is used as an output device. It is the principal output link between you and the computer. Its sole purpose is to allow the computer to communicate its actions to you (the user), so that you can act upon those actions to accomplish whatever job you are doing. See Figure 8-4. The monitor is one of the most important peripherals to a computer and is certainly the most visible. Quite often the term *monitor* is used interchangeably with such names as **screen**, **display**, **display device**, and **cathode-ray tube (CRT)**.

Depending on their design, monitors can display information in either monochrome or color. **Monochrome displays** produce output images using a single foreground color, such as black, and a single background color, such as white. This provides you with black text on a white background. Using a technique known as **reverse video** (that is, reversing the color of the pixels or dots on the screen), it is possible to have white text on a black background. Monochrome displays also come in amber (a yellowish brown) and

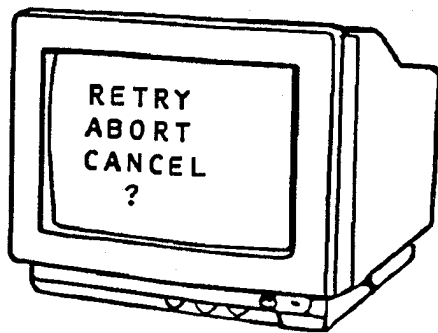

ISNP0118

Figure 8-4.—Computer monitor.

green. Amber and green are considered more pleasing and less stressful to the eyes than black and white. Most **color displays** are of the red-green-blue (RGB) type. The degree of color available depends on the sophistication of the display device and the amount of RAM available with the computer.

Disks and Disk Drives

Magnetic disks, regardless of their type or size, are the storage medium used with computers. A disk's physical characteristics, flat and round, allow the disk drive direct access to data and provide fast retrieval of information. Put simply, the processing unit electronically goes directly to a designated disk drive, seeks out the specific location on the disk where the desired data is stored, and immediately retrieves it. The disk drive does NOT have to read through a series of records before reaching the one desired as is the case with magnetic tape units.

The two forms of magnetic disks typically used with computers are the **floppy disk (diskette)** and the **hard disk**. Let's look at the sizes and construction of each and at the disk drive devices that read from and write to them.

DISKETTES AND DRIVES.— A diskette is also referred to as a “floppy disk,” or “floppy,” because it is a round, flexible platter enclosed in a plastic jacket. At present, diskettes come in two sizes (diameters)—5 1/4 inches and 3 1/2 inches (see figure 8-5),

Types of Diskettes.— The diskettes you will be using must be compatible with the floppy-disk drives on your computer system. Depending upon a disk drive's characteristics, it can record data on either **one side** of the diskette or **both**. It can also record data in one of several bit densities, depending upon how the diskette is formatted.

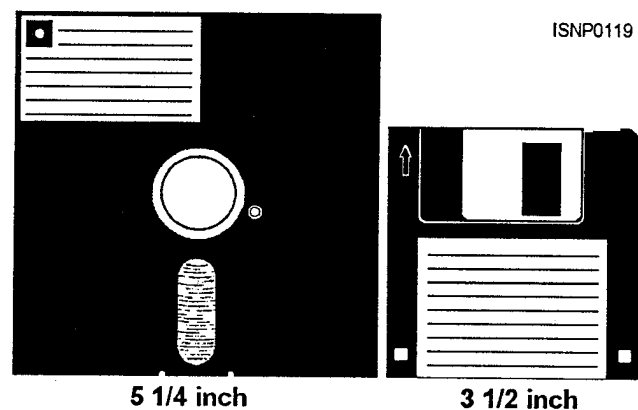

ISNP0119

5 1/4 inch

3 1/2 inch

figure 8-5.—Computer diskettes.

When you begin working with a new diskette, you must use your computer and a utility routine or program (in this case a formatter program) to format it if it is not factory-formatted. On most computer systems, using the **FORMAT** command will automatically format the diskette for you.

The important thing to remember is that no matter what brand of diskette you are working with, it must be formatted before it is usable for storing data.

Storage Capacity.— Although diskettes are relatively small in size compared to the 14-inch platters used on larger mainframe systems, they can store a respectable amount of data. Storage capacity will vary depending on the type of floppy you'll use.

Write-Protect Feature.— Like all other media, floppy disks/diskettes must also have a way of preventing accidental overwriting of data. This is done with a **write-protect notch** (or cut-out) located in a corner of the plastic jacket. Whether or not the write-protect notch is covered to protect the data on the diskette depends solely on the disk drive manufacturer. On most systems using 5 1/4-inch-diameter diskettes, covering the write-protect notch makes it impossible to write on the disk's surface. However, the opposite is true for systems using 3 1/2-inch-diameter diskettes. In this case, *uncovering* the write-protect notch makes writing impossible. In short, find out which is which on your particular system before you accidentally wipe out an entire diskette's worth of data. Now, let's talk a little more about floppy-disk drives and how they relate to you.

Floppy-disk Drives.— Floppy-disk drives are manufactured to read and write data, depending on the type of diskette used. Figure 8-6 shows a disk drive for 5 1/4-inch diskettes.

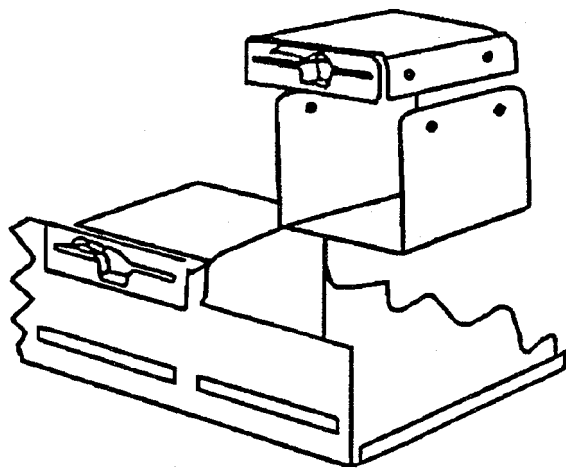

ISNP0120

Figure 8-6.—Floppy-disk drive.

HARD DISKS AND HARD-DISK DRIVES. — Although most computer systems you will be working with use some type of floppy-disk drive, you should also be aware that many computers also contain a sealed unit called a **hard-disk drive**. Unless the disk drive is an external type unit, you might never know it is there. floppy disk drives are easy to spot, for all you have to look for is the drive's door—that open slot where you insert the diskette. But hard-disk drives are normally sealed units that can be tucked away just about anywhere. Generally, you will find them inside the CPU (figure 8-7) in the space normally occupied by one of the floppy drives.

Hard-disk drives provide you "with many timesaving features not available nor possible with the tradition floppy-disk drives. These include increased access speeds, greater storage capacity, and overall convenience. Regardless of whether your computer has a hard-disk drive housed within the system unit or external to it, you need not bother having to search through file boxes filled with diskettes. Working with a hard disk is much easier because you can quickly end one program and start another, all through the operating system. There is no need to manually open, close, file away, or find anything. There is no more time-consuming initialization or rebooting from the floppy-disk drive, which involves finding and loading a program diskette, finding and loading the applications diskette, and finally getting down to work.

Hard-disk units consist of rigid metal platters that are tiered or stacked in the same way as a removable disk pack system. In most cases, the disks themselves are not removable. Therefore, they can be hermetically sealed in the storage unit along with the access

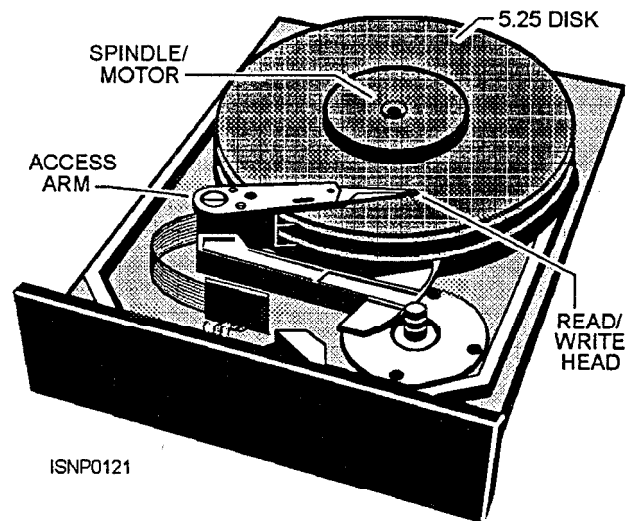

ISNP0121

Figure 8-7.—Internal hard-disk drive.

mechanism that contains the read/write heads. Hard disks also come in two sizes (diameters)—5.25 inches and 3.50 inches, with 3.50 being the most popular. Their storage capacities range from 50 megabytes to 2 gigabytes, with the majority in the 200- to 500-megabyte range.

As we mentioned earlier, hard disks can be either internal or external. The external hard disk can be a detachable unit, as shown in figure 8-8. You should also note that the disk drive shown in figure 8-8 is a portable hard drive in that the hard disk is removable. The hard disks and the read/write mechanism are enclosed within a rugged case. The result is a self-contained hard disk you can insert like a floppy and remove for reasons of security.

Printers

In the early days of computers, the choice of printers was very limited. Today, the choices of printers and printer options are almost mind-boggling.

Many computer printers can print subscripts and superscripts, print in several different colors, print graphic material, and output text in several different types of styles (fonts).

Some printers print in a single direction only, like the conventional typewriter, whereas others print in both directions (bidirectional) to save on time-consuming carriage returns. Many come with

either a friction feed (for handling single-sheet paper) or an adjustable tractor feed (for handling continuous forms) and some even have both.

You can initiate a wide range of printer functions either through the applications program you are working with or by using the controls located on the front of the printer's operating panel. These controls can be buttons, lights, and switches. With a simple touch of a button, you can change such things as type style, letter quality, pitch, and spacing. It's that simple.

Although the variety of printers is great, most of the printers you will use will be the low-speed type, usually dot-matrix. They have print rates of 200 to 800 characters per second and usually output this information one character at a time. Figure 8-9 shows a typical dot-matrix printer. Basically, the only major difference between printers designed for desktop computers and those used on larger computers are their size and the speed at which they print. Other than that, they are very much alike in terms of setup, operation, and operational features.

Different technologies enable manufacturers to produce a variety of computer printer types. These technologies result in daisy-wheel (which prints solid characters), dot-matrix (which forms characters using a series of dots), ink-jet, xerographic, electrostatic, electrosensitive, electrothermal, and laser printers. A brief explanation of each type is provided below:

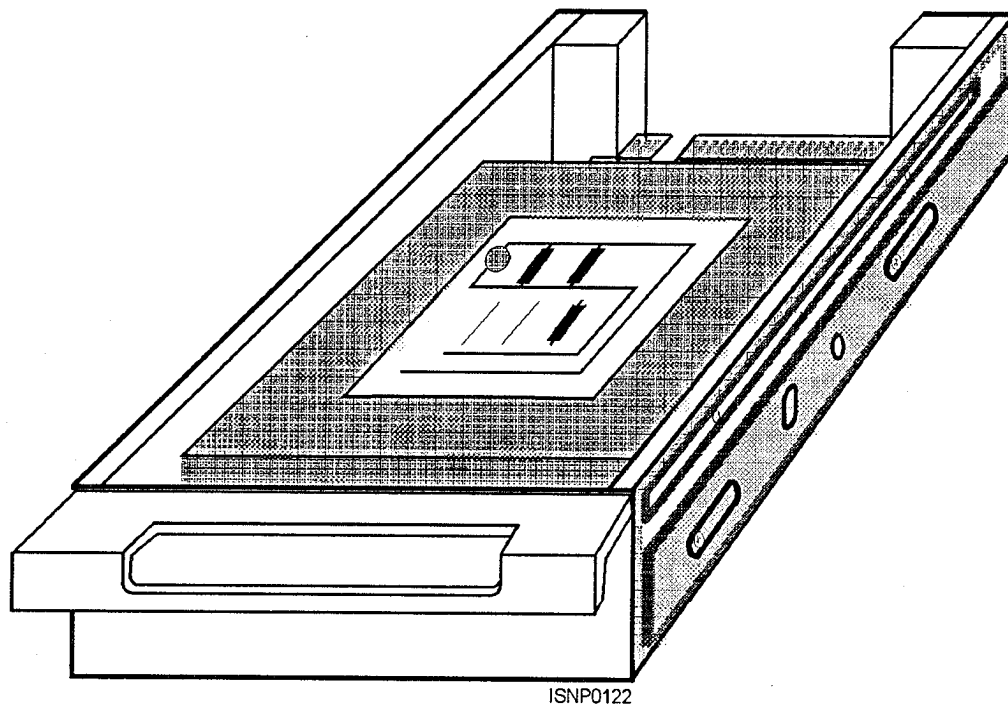
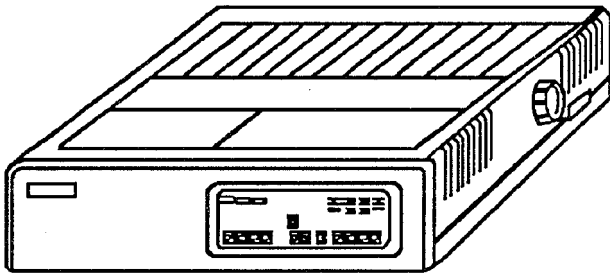

Figure 8-8.—External hard-disk drive with removable disk cartridge.



ISNP0123

Figure 8-9.—Dot-matrix printer.

DAISY-WHEEL PRINTER.— The daisy-wheel printer provides print quality similar to that of a typewriter. The daisy-wheel printer uses a round disk with embossed characters located at the end of each petal-like projection or arm (one character per petal), similar to the petals of a daisy. A drive motor spins the wheel at a high rate of speed and stops it when the desired character spins to the correct position. The print hammer strikes that character's arm, causing the character to be printed on the paper. As soon as the character is printed, the daisy wheel moves again, until it stops to print the next character. This process continues until the line of text is completed. The speed of the daisy-wheel printer ranges from 30 to 60 characters per second (cps).

DOT-MATRIX PRINTER.— The dot-matrix printer uses a print head made up of pins. It creates the characters by using these pins to generate characters one dot at a time.

INK-JET PRINTERS.— Ink-jet printers use a technique very similar to the way larger letters are created with a can of spray paint and stencils. A spray of electrically charged ink is shot toward the paper. Before reaching the paper, the ink is passed through an electrical field, which forms the letters in a matrix form. The print resulting from this process consists of easy-to-read, high-quality characters. Some manufactures use large droplets of ink for faster printing, whereas others use small droplets for better clarity but with slightly reduced printing speeds. This type of printer can print up to 300 characters per second.

XEROGRAPHIC PRINTERS.— Xerographic printers use a printing technique very similar to the methods used in duplicating or copying machines. These printers can operate at speeds up to 4,000 lines per minute.

ELECTROSTATIC PRINTERS.— Electrostatic printers use a special photographic paper that allows characters to be etched onto the paper using a stylus.

The stylus, made up of tiny wires, forms characters by placing an electrostatically-charged image on the paper. Then, as the paper is moved through a toner solution containing ink particles, the ink adheres to the charges that form a pattern on the paper to develop the character. This toner and developing stage is very messy. For this reason, it is done inside the machine. This type of printer can be used for both printing and plotting (displaying graphic output), and can print up to 5,000 lines per minute.

ELECTROSENSITIVE PRINTERS.— Electro-sensitive printers use a special metallic-coated paper that is silver in color before any printing is done. As the paper moves through the printer, tiny wires selectively apply voltage, causing the metallic coating to be burned away. This type of printer is relatively fast, but the quality of the print is relatively poor. The resulting copy has black characters on silver paper. These printers can print up to 3,000 lines per minute or 6,600 characters per second.

ELECTROTHERMAL PRINTERS.— Electrothermal printers use a heat-sensitive paper to create characters. This is done by selectively heating tiny wires, or pins, as they are passed over the paper. As the pins heat up, certain areas of the paper change color because the paper is sensitive to heat. This allows the characters to become visible. This type of printer cannot use preprinted forms because of the special nature of the paper. You will find that as the paper gets older, the characters begin to fade. These printers can print up to 5,000 lines per minute.

LASER PRINTERS.— Laser printers direct a beam of light through a rotating disk containing the full range of print characters. The appropriate character image is directed onto photographic paper, which is then put through a toner, developed, and used to make additional copies. The print resulting from this process consists of sharp, clean images that are easy on the eyes. These printers can print up to 20,000 plus lines per minute.

Accessories and Other Hardware

In addition to monitors, disk drives, keyboards, and printers, you may find a number of other attachments to computer systems. These might include a mouse device, cassette tape drive, optical scanner, CD-ROM drive, switch box, modem, and so on.

MOUSE DEVICE.— You may have a mouse device, or “mouse,” (figure 8-10) attached to your computer. A mouse allows you to freehand sketch or to select items from menus on the display screen. As you move the mouse, the cursor moves to the corresponding location on the display screen. For example, to select an item from the menu, you first move the mouse to move the cursor to the item and then press a button on the mouse to select the item.

TAPE DRIVE.— You can use cartridge or cassette tapes to provide backup to the hard drive. The tape drive (figure 8-11) may be internal or external to the CPU. A tape drive makes a good, reliable backup system for the micro since tape drives hold 60Mb or more of data. If a tape drive is not available, you can back up your data on floppy disks.

OPTICAL SCANNER.— An optical scanner (figure 8-12) allows you to scan (read) graphic art or text directly into the computer. This saves redrawing or retyping.

CD-ROM DRIVE.— A CD-ROM (compact disk-read only memory) drive (figure 8-13) allows you to read data stored on compact disks. The CD-ROM drive can be internal or external to the system unit. CD-ROM technology is the same as that used for audio disks except that it includes routines for detecting and correcting data errors. Compact disks can hold a vast amount of information, 550Mb or more. They are used when the same information is needed by many and the information is fairly constant. For example, libraries can put all the information patrons need about documents and publications on a CD-ROM. On a CD-ROM, recorded information cannot be erased or changed, but it can be read many times. The expression

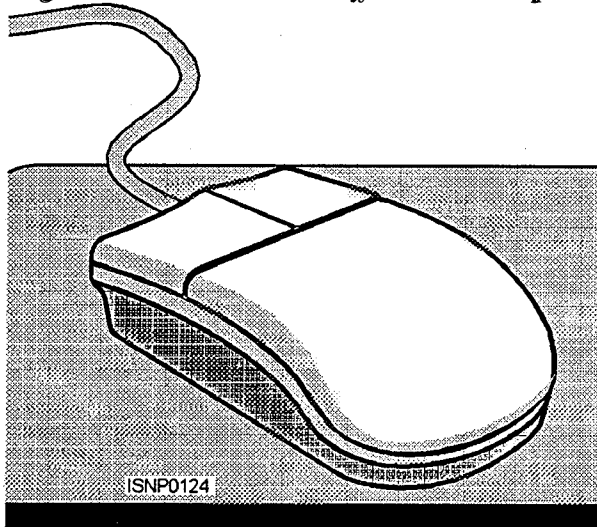

ISNP0124

Figure 8-10.—Mouse device.

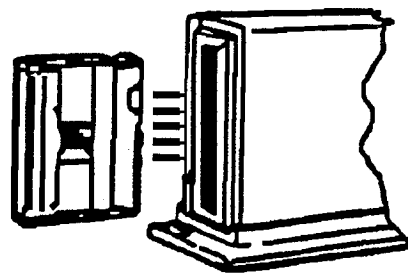

ISNP0125

Figure 8-11.—Cassette tape and drive.

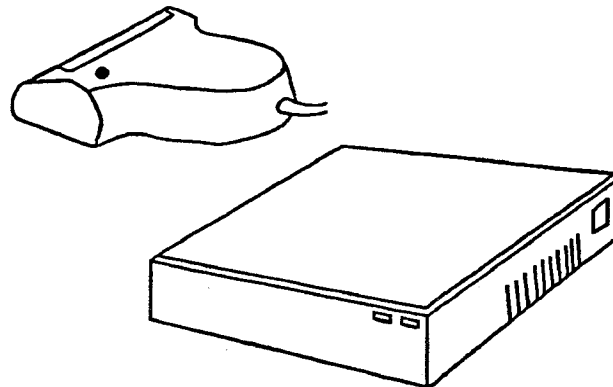

ISNP0126

Figure 8-12.—Optical scanner.

Write Once, Read Many (WORM) describes this type of technology.

SWITCH BOX.— A switch box (figure 8-14) allows multiple connections between computers and printers. For example, two or more computers can use one printer, or one computer can use two or more

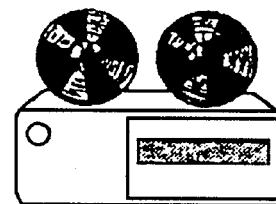

ISNP0127

Figure 8-13.—CD-ROM drive.

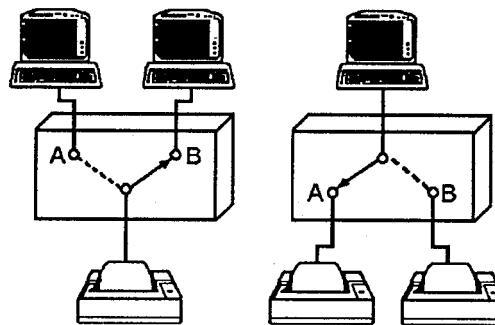

ISNP0128

Figure 8-14.—Switch boxes.

printers. To use a switch box, you must first connect a cable between the switch box and each device. You then switch the setting, A or B, on the box to switch signal lines without disconnecting and reconnecting cables. Switches range from this simple, manually operated switch box with two settings to switches that select signal lines automatically and provide buffering capability. Some also provide for both parallel and serial devices.

MODEM.— A modem (figure 8-15) provides communication between systems. Through a modem, you can have your system send or receive data over phone lines. You may also use a special cable, called a *null modem cable*, to establish communications between systems that are relatively close to one another. A null modem cable eliminates the need for modems and phone lines. If you use null modem cables, you may need *gender connectors* or *gender changers* to connect like connectors.

As you can see, a basic (low-end) system is only a beginning. As you become an experienced computer user and as technology improves, you will discover even more uses for computers.

SETTING UP AND OPERATING COMPUTERS

Before you begin to setup or operate a computer, know what you are going to do. THINK FIRST, think before you act, and start with the documentation, NOT with the hardware and software.

USING DOCUMENTATION

The first thing you will want to do when you install or start using a system or a new software package is to become familiar with the documentation that comes with it. You will also want to see what other documentation and training materials are available.

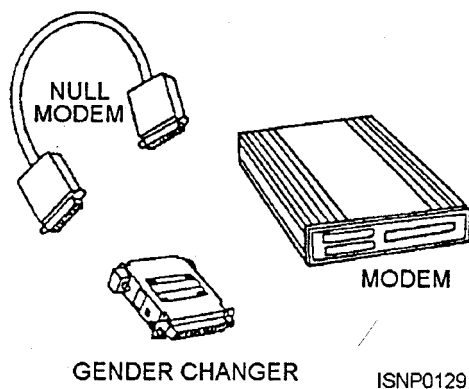

Figure 8-15.—Modems.

Don't get discouraged over the amount of reading material provided to you. It takes time to learn something new, and it takes practice to become proficient. Spend time learning all you can about the software and hardware. Refer to manuals and other help aids when you have problems. You may also have in-house user's manuals to use.

User's Manuals

User's manuals tell you about the hardware and how to install and configure it. Each device will probably have its own user's manual. Most manuals that come with the system and software include sections with names like *Getting Started*, *Installation*, *Using the Software/System/Commands*, *Reference*, *Error Messages*, and *Troubleshooting*. A learning or self-study section may also be included. When you first begin, take the appropriate manual and look at the headings in the table of contents. Then browse through the appendices, glossary, and index to become familiar with what they contain. This will give you an idea of what information you can find in the manual and how the information is organized. The more you know about where to find information when you need it, the more professional and confident you will be.

Training Materials and Aids

Software packages often include an on-line tutorial on disk. If the package you are using has one, take time to go through it. It will give you at least an overview of what the software can do and how it works. The system may also have hypertext. Hypertext is an on-line data management program that allows you to navigate very quickly through all sorts of information in connection with the applications program you are using. An entire user's manual and applicable documentation are readily available to you with a couple of keystrokes. Hypertext is especially useful for users who do not have access to manuals or when documentation is stored out of reach.

Video, audio, or other on-line tutorial- training materials may be available at your command. For disk operating systems that are in general use and for many software packages, you can obtain textbooks, training manuals, and supplementary manuals written by people other than the software vendor. Local bookstores and libraries may have them.

Help Aids

Other help aids are help screens, quick reference cards, and keyboard templates. Help screens are part of

the program and can usually be called onto the display screen at anytime while the program is running. This means if you get stuck or confused about how to do some function when you are in the middle of a task, you can call the help screen function and have it display information relating to your problem. Reference cards usually list the features and the keystrokes that activate each feature. Keyboard templates fit over or above the keys. They identify each feature and its associated keystrokes. These aids are very helpful, especially when you are jumping back and forth between different programs that have assigned different meanings to the function keys. A quick look at a template or a reference card, or a call for a help screen maybe all you need to remind you of how something works. This is especially true once you have become an experienced user on a particular software package.

In-house User's Manuals

To implement your own command's policy and procedures, you may have one or more in-house user's manuals. These will generally cover the use of computers, what software to use, any specially designed routines and programs authorized for use, standards for labeling diskettes and files, backup procedures, maintenance procedures, security procedures, and so on.

USING SOFTWARE

Once your software is installed and set, you should boot either from the hard drive or by inserting the diskette that contains the operating system. You can set up the system so it will automatically boot when power is turned on to the system. Next, tell the operating system which program to use. Do this by entering the file name of the program following a prompt given by the operating system. For example, if the program you wish to use is named WPP (for word processing program), enter WPP and press the ENTER (RETURN) key. If you are using a hard disk, be sure to specify the directory used when you installed and set up the program. The operating system will then load the program into memory and make the system ready to do the work. From this point on, follow the instructions of the software package; in this example, a word processing program. Refer to the manufacturer's user's manual and any in-house user's manuals that apply.

When you have finished your processing, return to the operating system before turning off the power. Do this by saving your work and exiting the program

properly. Each program will have a procedure or command to end execution of the program and return to the operating system. If you are using diskettes, remove them from the drives, put them in protective jackets (if necessary), and file them in an appropriate place. If you are using a hard-disk drive, enter the operating system command to park the read/write heads. This will move the heads away from data storage areas so that data will not be destroyed if the system is moved or accidentally bumped. Then turn the power OFF.

Care, Handling, and Protection of Diskettes

Diskettes are very sensitive; they cannot tolerate rough handling, extreme heat and cold, high and low humidity, static electricity, and contaminants, such as dirt, dust, liquids, and grease. It is, therefore, very important to manage and maintain your diskettes, as well as other types of magnetic media, properly.

Because diskette mistreatment is usually fatal to data, be sure to follow established procedures for caring for, handling, and protecting diskettes. Once a diskette is damaged, there's little chance of retrieving the data. Go over the fundamentals on how to care for, handle, and protect your diskettes. This simple precautionary approach will save you hours of aggravation and system downtime.

CARE AND HANDLING OF DISKETTES.—

Be sure to keep your diskettes (and your computer) away from cigarette smoke, greasy foods, and beverages that might be spilled on them. These substances can cause irreparable damage to diskettes and the computer.

Never bend or fold diskettes. The diskette drive only accepts a diskette that is absolutely flat. If it is bent or crinkled, it may cause severe damage to the read/write heads as well as make the data unretrievable.

When you prepare an external file label, never mark on a label with a pencil or ball-point pen if the label is already affixed to the diskette's jacket. Instead, use a felt-tipped marker and, even then, be sure to press lightly. Unless labels are scarce, it is far better to prepare a new label before placing it on the diskette. Then, using extreme care, remove any label on the diskette and place the new one on. Never stack labels one on top of the other on a diskette. Doing so may cause problems when you insert the diskette into the drive.

PROTECTING DISKETTES.— How many times have you read or heard the following statements: “Whenever diskettes are not being used, they should be stored in a protective envelope”; or “Whenever a diskette is removed from its protective envelope, never touch any of the diskette’s exposed parts”; a thousand times maybe? Be careful in handling diskettes.

Temperature and humidity are also important. Never leave diskettes in direct sunlight or in areas where the humidity is extremely high or low. High humidity can cause moisture to form on the diskette’s surface or possibly warp the diskette’s protective jacket. Low humidity makes conditions ideal for the buildup of static electricity, which you can transfer or discharge to a diskette, thereby destroying the data. Diskettes are designed to withstand temperatures from 50 to 125°F (10 to 52°C) and a relative humidity of 8 to 80 percent. Generally speaking, a combination of temperature and humidity in which you are comfortable will also be comfortable for your diskettes.

You must also keep all types of magnetic media, including diskettes, at least 1 foot away from anything that generates a magnetic field. This includes magnets of any kind, such as those found in telephones, stereo speakers, and paper-clip dispensers, as well as magnets on copyholders and inside of printers. It also includes motors, such as those found in portable fans and floor buffers and polishers.

File and Disk Management

File and disk management are other areas that will help you as a user. You probably don’t know the “agony of delete” or the problems sometimes caused by very large files. Think about file management. Consider the following:

- when and how to name, clean up, backup files;
- where and how to physically store files;
- how to protect files; and
- how to organize files on disks.

Now let’s examine some of the considerations for setting up files and file management procedures for computers: naming files, disk file organization, and file backup. We will use a disk operating system (DOS) as the operating system for the examples in this section.

NAMING FILES.— Every newly created file must be given a file name if it is to be stored (written and given an address) on disk. When the operating system looks for a file name, it looks up the address in its

“address book,” the directory. The directory is maintained in a fixed location on every disk.

Every operating system has a system for naming files. In DOS, filenames have two parts. The first part, the primary file name, names the file and can be from one to eight characters in length. The second part, called the file name extension, is optional, and can be from one to three characters. Although the extension is optional, the primary part of the file name is NOT. An extension cannot name a file; it can only be used to further qualify or describe a file. If both parts are used, they must be separated by a period; for example, LESSON.WPF. To name a file (including its extension), you may use any combination of the following characters: the letters A through Z (upper and lower case); the numbers 0 through 9; the special characters \$, #, !, %, (), -, { }, _; and the left and right apostrophe.

Why would you want to use an extension? you might ask. Let’s assume you create a file that contains all E-4 evaluations for the year 1993 and name the file DIV-EVAL. DIV-EVAL is a perfectly good and valid name under DOS. However, it is entirely possible that you may want to create more than one file called DIV-EVAL in the years that follow. If so, you will need to add a file name extension to differentiate between the files. For example, you could label the 1993 evals DIV-EVAL.93, the next year’s DIV-EVAL.94, the following year’s DIV-EVAL.95, and so on. In this case, the years 93, 94, and 95 are the extensions.

Some extensions have **special meanings** in DOS and are either created by DOS or indicate that the file contains a special type of program or data. For this reason, use extreme caution and avoid using file extensions defined by the program or operating system you are using. Examples of extensions assigned by DOS are as follows:

COM, EXE, SYS, BAT— File extensions, such as COM (command), EXE (executable), SYS (system), and BAT (batch), contain executable code. That is, the code is actually understood by the hardware when the programs are run.

BAK— When opening a text file, the DOS program automatically makes a backup copy, with the extension BAK.

BAS— BAS refers to a source program written in the BASIC language.

COB— COB refers to a source program written in COBOL.

HEX— HEX refers to a special type of file where all information has been stored in the HEXADECIMAL format.

Various applications software packages automatically add an extension. For example, ENABLE adds **WPF**; DBASE adds **DBF**, **NDX**, **FRM**, and **MEM**; and LOTUS adds **WK1**, **PRN**, and **PIC**.

Before you start creating files, devise a naming scheme that is logical and comfortable for you. Your command may have already addressed this area and come up with descriptive naming conventions. If so, you, of course, must use those. Whatever method you use, be sure that it is indeed a method and NOT just a haphazard way of naming files. You are probably familiar with organizing file folders in the drawers of a filing cabinet. Use this analogy as a starting point in understanding how to organize your disk files in much the same manner.

DIRECTORIES.— File directories, like the folders that are filed away in drawers by category, or like the yellow pages of the phone book, provide you with a way to organize and find files by category and name.

Most operating systems give you the option of creating either single or multiple-file directories, regardless of whether your system uses floppy disks or a hard disk. Disks with only one directory are said to be of the *unstructured* or *flat* type. Disks having more than one directory are said to be *hierarchical* or *tree* structured because they contain a root directory and several subdirectories, each subdirectory containing files with common subject matter. We use the term *tree structure* because this type of directory takes on the appearance of an upside down tree with the trunk of the tree or root directory located at the top and all the branches or subdirectories located below.

As the number of files on a disk increases, so does the need to have a disk that is well organized. A well-organized disk can save you a considerable amount of time and frustration in locating files.

Whenever you format a disk, a single directory, called a *root directory*, is created. Once the disk is formatted, you can instruct DOS to create or make other directories using a command, such as MKDIR or just plain MD. These additional directories are called *subdirectories*. Each of these subdirectories can, in turn, have subdirectories. Directories, regardless of their level, are given names, just like any other files. DOS keeps track of each directory the same way it does your files. Using various DOS file-handling

commands, you can create (MKDIR or MD), change (CHDIR or CD), and remove (RMDIR or RD) directories and subdirectories. To move through the tree structure (UP or DOWN), you must issue commands that use a path name. A path name is a list of the directories (which might end with a file name) that DOS must follow to find a given directory/subdirectory or file name.

Once you have grouped related files into a subdirectory, you can act on them as a unit. The DOS file-handling commands can be applied to an entire subdirectory of files in a single stroke. For example, you can issue commands to copy, print, or delete all the files in a subdirectory as easily as you can for a single file. Other files on the same disk, but in different directories, go unused and undisturbed. Subdirectories are especially helpful when you work with hard disks because of their large storage capacities.

To learn more about DOS directory structures and commands, read the DOS reference guide that accompanies your DOS software.

BACKING UP FILES.— You have heard it before, but we must say it again: BACK UP your programs and data files. If you don't, you will eventually lose all or part of your data, and the only person you can blame is yourself.

Data can be lost or damaged in a number of ways. Common causes of data loss are power surges and drops, power failures, and user errors. User errors top the list. Less common but potentially disastrous are fire, theft, vandalism, and natural disasters.

How often have you come close to erasing a file or formatting a floppy or hard disk by accident? Probably more times than you care to admit. No matter how many precautions you take, you can't prevent all the potential ways data can be lost. You can certainly reduce their adverse effects by backing up your files on a regular basis.

When working with data files, you will want to back them up at least on a daily basis either to tape, to diskettes, or to another hard disk. For our example, we will use two diskettes. A technique referred to as the *odd/even backup* uses two diskettes. Label one diskette as "odd" and the other as "even." When you make your backups, use the odd diskette on odd days and the even diskette on even days. This pays off when you find that you inadvertently made errors to a file the day before, and you backed up that file onto your backup diskette. With this system, you can go back 2 days if necessary.

No matter how many backups you make (two, three, or one for everyday of the week) or what method you use to make them, they are worthless if they are destroyed along with your computer. You need to make multiple backups and store a set in an area away from your working area or, as a minimum, in a data safe. This will require some extra effort, but it will more than pay for itself, should you ever experience a data loss,

System Care and User Maintenance

The fact that computer systems are small and out in the workspaces doesn't mean they don't need operator maintenance. They do. Dust, dirt, and other materials accumulate on diskettes, disk drives, printers, display screens, and keyboards. Static electricity can also be a major problem, especially in areas where the humidity is low.

Keep your system as clean as possible. One way to do this is by using dust covers. This, of course, only protects the system when it is not in use. You will still need to clean the components on a regular basis.

User maintenance is important for the effective operation of computer systems. It helps prevent data loss and will increase the life of the computer system and its components. To increase the dependability of your computer, establish a schedule for routine user maintenance, then follow the schedule.

Troubleshooting and Isolating Problems

No matter how dependable your computer system seems to be, it will have problems from time to time. The problems will range from simple to disastrous. The printer may not be printing because it is out of paper. The disk drive may not be reading because the drive latch is not closed. The printer maybe printing garbage because the incorrect printer definition is used. The hard drive may be having excessive read errors. The problems may be **user errors, software problems, or hardware malfunctions**. Identifying the source of a problem is sometimes easy. In other cases, it may be difficult. The immediate response to a problem is troubleshooting, either by you or someone more experienced in solving computer problems.

TROUBLESHOOTING.— To help increase your computer's "up" time, learn all you can about common problems. For example, what does it mean if the monitor screen goes blank? Is the problem a simple one, such as the monitor having an automatic function that turns off the screen when it hasn't been used in a specified amount of time? Pressing any key will

reactivate the screen. Or, have the brightness or contrast thumbwheels been turned, causing the screen to look blank? A turn of a thumbwheel may bring the monitor screen back to light. Has a cable become disconnected? Has the power been turned off? Is the monitor or power strip unplugged? Or, is the power supply no longer working? Did you hit a combination of keys by mistake that caused the screen to go blank except for the status lines? Look at the status lines to see if they provide information.

Whatever the symptoms, look first for simple, logical answers. Check all cable and outlet connections. Check to see that each component of the system is plugged in properly. Check to see that the proper options are selected. For example, is the printer in a "ready" status? Is the printer out of paper? Is the correct mode of operation selected, either through the buttons on the printer or through software? If the software and hardware allow using several printers, is the correct one selected, and are the correct manual selections made when a switch box is used?

We could go on and on with examples. The point is, **learn from experience**. Keep a list of symptoms, probable causes, and ways you can trace a problem to its cause. This will help you to diagnose and troubleshoot problems. Look in the documentation. It usually has a section that lists conditions and possible causes. Always check for error messages. Check any status information on the screen. As you become an experienced computer user, you will find that new users tend to make the same mistakes over and over, especially while learning. Help them by telling them about common problems, the reasons for the problems, and ways to avoid having the problems happen to them.

WORKING WITH SOFTWARE PACKAGES

When working with packaged software, you will be concerned with what it does, how it does it, and how you are to interact with it. For each different type of application package, you will be confronted with a new vocabulary. For example, the terms used with word processing come primarily from the office/clerical environment (margins, tab sets, indenting, paragraphs, and so on). The terms used with desktop publishing come from the printing industry (fonts, type styles, points, and so on). Spreadsheets bring us the vocabulary of an accountant or bookkeeper (worksheets, rows, columns, data cells). In the following sections, we will look at the common features, then at the peculiar features of several different types of software

package-word processing, spreadsheet, database, and utilities.

USING SOFTWARE PACKAGES

Regardless of the type of software package you are using on your computer, as a minimum, you will need to know how to perform the following seven general operations:

- **Access** and **execute** the packaged software from the operating system;
- **Create** a new file or **retrieve** a previously created file on disk/diskette or tape;
- **Save** a file onto disk/diskette or tape;
- **Delete** a file stored on disk/diskette or tape;
- **Print** a file;
- Indicate to the packaged software that you want to **stop** working on what you are currently doing to do something on another file; and
- **Terminate** your work via the packaged software and return to the operating system.

NOTE: Each software package will have specific ways for you to perform these functions. Check the software user's guide for specific instructions.

A major consideration for a person working with packaged software is file management. You will need to know how files are set up, coded, named, backed up, and accessed. You will also need to know who can access the files, whether you can control access by others, whether you can protect the data, and whether the data is encrypted.

Learning About Software

The first thing you will learn is that there is a lot to learn. You will need to know what functions you can perform, what keys activate what functions, and how to save the work (files) you create. If a tutorial or learning section comes with the software, start with it. It will give you an overview. Then begin by experimenting and practicing on something you cannot hurt or destroy. Don't start with the master copy of a large database file. Instead create a few records in a test file and practice on it. Try out each function, then try the functions in combination with other functions. As you begin to feel comfortable with the software, make mistakes on purpose to see what happens. Does the software give

you an error message? Can you recover? Does the software provide an undelete feature that lets you cancel what you just did? How much protection from error is built into the software? Does it give you a message, such as: Do you really want to delete this file? Or, does it just assume that when you hit the delete key you mean to delete? Most of the better software packages have built-in safeguards to protect us from ourselves. Recovery from user errors is a very important feature of many software packages.

Interacting with Software Packages

Basically, there are only a few ways to tell software what to do. They are as follows:

- **Direct commands**— You enter words or characters via the keyboard to tell the software what to do. These words and characters are predefined by the software to perform specific tasks.
- **Menus**— You select the function or command you want performed from a list presented on the display screen by the software.
- **Function keys**— You select the function key (F1, F2, and so on) that is predefined to tell the software what you want it to do. This enables you to perform some of the more common commands without going through menus and with fewer keystrokes than are required for direct commands.
- **Programs/macros**— You execute routines (a series of instructions or keystrokes) that have been developed and stored previously.

Which of these methods you will use depends on the design of the software—not all software includes all methods. Some software gives you a choice, letting you select the method you prefer. When you are learning the software, it is usually easier to use a menu because all the choices are presented. Once you have learned the software, you may prefer direct commands because you do not have to work your way through a series of menus to find the function or command that you want. Programs and macros are most useful for repetitive tasks. They enable you to enter the sequence of keystrokes (steps) or characters you want to repeat. Once you have entered and stored the necessary keystrokes and characters, you can execute the entire sequence with one or two keystrokes—a real time-saver.

Becoming a Proficient User

You will also learn that software does not do everything you want in the way you would like. The more you work with a package, the more you will be able to find ways around what you consider deficiencies. You will also learn that you can compensate for these problems by writing and saving your own routines, programs, or macros to perform some of the more complex or awkward functions. Some packages enable you to define your own function keys, change the function of a key, or store routines as macro instructions. These are all desirable features for the more sophisticated users. This also means routines can be developed by experienced, proficient users for use by other users.

Do not hesitate to learn from others, and do not limit your study. Ask others how they are using a package. What “tricks” have they learned and found useful? What routines or macros have they designed to perform recurring functions? Build on their knowledge and share yours. You might even institute a users’ group. It need not be formally organized—maybe during the noontime meal once a month.

Now let’s take a more in-depth look at some of the more commonly used software packages—word processing, spreadsheet, database management, and desktop publishing software.

WORD PROCESSING PACKAGES

Word processing packages are readily available for use in office environments. They enable you to create, modify (insert, delete, rearrange), save, copy, and print documents. See figure 8-16. The usual method of entering a document is to type it on a keyboard. Another method is to use a scanner to read a printed document and encode it into a digital file for computer processing. You might also receive a document that has been transmitted over a network or phone system.

Creating and Modifying Documents

To create a new document, you will start by telling the system you want to create a document. In some packages, this is the default option or the option you get if you do not specify something else. When you load and execute the program, you are in the create mode and simply need to start typing. The software will probably have a number of defaults that can be set up for your installation. For example, you can probably have defaults set to 8 1/2-inch by 11-inch paper, with a

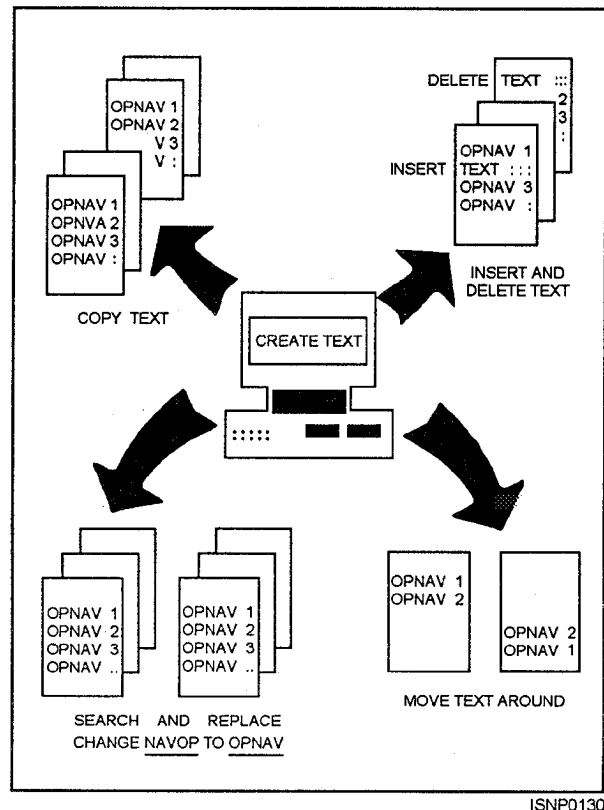

ISNP0130

Figure 8-16.—Examples of word processing program features.

1 1/2-inch margin at the top, a 1-inch margin at the bottom, and 1/2-inch margins left and right. You may also be able to have tabs set as a default option for indenting paragraphs.

Regardless of how the original document is entered, it eventually ends up as a data file on some type of secondary storage media. To modify the document (add, change, or delete), you must retrieve its file into the computer’s memory. The software will display the document on the screen. You can then make entries by moving the cursor to the places in the document where you want to make changes. Two modes of operation are used for making changes— *typeover* and *insert*. As the words imply, if you are in the **typeover mode**, you will replace what is presently there. If you are in the **insert mode**, the material to the right of the cursor will move to the right as you enter new material.

The basic features you will use are as follows:

- **Cursor movement keys**— Allow you to move the cursor up or down, right or left, to the top or bottom of the document, or to the next or previous page or screen.

- **Insert mode**— Allows you to add letters and characters, words, sentences, and so on.
- **Delete key**— Allows you to take out unwanted characters, words, sentences, and so on.
- **Backspace key**— Allows you to erase words to the left of the cursor one character at a time. (NOTE: In some packages, this key may be defined differently. For example, it may backspace without deleting.)
- **Typeover mode**— Allows you to replace something by typing over it.
- **Wordwrap**— As you enter text, words automatically move to the next line when the right margin is reached. You do not have to press the return key at the end of each line as you do on a typewriter.
- **Cut and paste function**— Allows you to move material from one place to another in a document.
- **Function keys**— Allow you to underline, center, tab, indent; put text in bold; use subscripts or superscripts. You can put text in columns; add headers, footers, footnotes, page numbers, date, and so on. You can also search to find a character string or function code in the document.

Special Features

Many word processing programs include a dictionary and a thesaurus. These enable you to check for correct spelling and to look for synonyms. Some of the dictionary routines even provide a list of correctly spelled words to replace a possibly misspelled word. In this case, you can correct a misspelled word by selecting the correctly spelled word from the list on the display screen. The same is true of the thesaurus; the software lists synonyms on the screen. You select the one you want and the software replaces the original word with the selected synonym.

Some word processing programs have *automatic paragraph numbering* and *outlining* features. Once you have created an outline or document, you can delete or add entries and the software will automatically renumber or reletter the outline or paragraphs in the document.

Some word processing programs have *indexing* capabilities. You can tell the software which words or terms to include in an index. The software will then

automatically create the index in alphabetical order, with the appropriate page numbers. Some enable you to create a *table of contents* or other types of lists.

Some word processing programs even include some of the features of a *spreadsheet* package. While they may not be as easy to use or as sophisticated, they do allow you to define *columns* and *rows* and perform some *arithmetic functions*. For example, you may total the contents of a column or calculate the total cost of an order by having the software multiply the number of items by unit cost and put the result in another column.

Some word processing programs enable you to set up *records* with defined *fields*. For example, you could set up a file of records with names and addresses. Let's say your organization sends a memo each month to the same list of organizations. Using this feature of the word processing program, you could create one letter and have the names and addresses inserted into (merged with) the letter automatically, in the proper places. This is the same feature that sweepstakes companies use to insert your name throughout their letters to you to personalize them. This is sometimes called the "mail merge" function. It is unlike the merge function we think of in data processing in which the records in two or more like files are sorted in the same sequence by keys and then merged together into a single file. In mail merge, the variable information (name, address, and so on) is inserted in predefined places in a document and the document is printed.

Some word processing programs include many of the features of desktop publishing. You can view a finished document on the screen as it will appear on paper. You can scan art and insert it into the document. You can use a variety of type styles and sizes (fonts) if your printer can handle them.

Capabilities are continually being added and combined. You might have several electronic office tools all rolled up into one package—word processing with mail merge, database with report capability, spreadsheet with charting capability, and a communications package. You will be able to use each tool as a separate entity, or you can integrate them to produce sophisticated reports by combining text, graphics, and images in relatively complex multicolumn layouts. These packages will also include a graphical user interface (GUI) or lists of options (menus) presented on the screen. This prevents you from having to memorize numerous computer commands to get the computer to do what you want.

SPREADSHEET PACKAGES

Simply defined, a spreadsheet electronically duplicates an accountant's or bookkeeper's tools, which normally consist of a ledger pad, a pencil (with an eraser), and a calculator. When using spreadsheet software, you enter and change data (figures of various types) by typing on a keyboard rather than writing with a pencil. You are able to view your figures on the computer's monitor rather than having to read a ledger pad. The data is presented as it would appear on paper, in rows and columns. Figure 8-17 is an example. Many everyday tasks can be managed with spreadsheet software. The computer can perform a variety of mathematical calculations—from simple addition, subtraction, multiplication, and division to trigonometry and statistical and business calculations.

Understanding Spreadsheets

Before you can understand how a spreadsheet program works, you must first have an understanding of what the terms **record**, **column**, and **data cell** mean,

- **Record**— A record is represented by a line (row) of data items of information on a spreadsheet. This is the horizontal component of a spreadsheet. Normally a record contains

information about one particular item or topic; for example: a person or a piece of equipment. Spreadsheet rows are usually identified by numbers (1, 2, 3, and so on).

- **Column**— A column is the vertical component of a spreadsheet. A record (or row) can have many associated columns, such as base pay, FICA, state tax, federal tax, and so on. Each column contains one type of information and is normally labeled to identify the type it maintains, such as base pay. The columns are usually identified by letters (A, B, C, D, and so on).
- **Data cell**— A data cell contains one piece of information associated with a particular record. Thus, a record or row that contains seven pieces of information will have—you guessed it—seven data cells. A data cell is symbolically identified by using some type of common notation—usually column, row. Therefore, if you have a spreadsheet with 20 records, each with 7 columns of information, the rows will be numbered from 1 through 20, and the 7 columns will be identified by the letters A through G. In this way, the fourth column, sixth row of the spreadsheet will be data cell D6, which in figure 8-17 contains the value 2158.10.

CELL ADDRESS OF THE CURSOR				MODE INDICATOR			
DG: 2158.10				READY			
	A	B	C	D	E	F	G
1	NAME	SSN	RATE	BASE PAY	FICA	ST. TAX	FED TAX
2	ABLE A.	111111111	OX3	1122.90	74.36	.00	168.44
3	ABLE B.	222222222	ETCS	2520.30	136.15	87.87	378.04
4	JANE J.	333333333	HM1	1707.30	102.85	.00	256.10
5	MARY S.	444444444	OP2		82.50	49.75	190.25
6	PAUL T.	555555555	RMCS	2158.10	124.90	119.55	323.42
7
8
9
10
11
..
..
..
20	WATER T.	999999999	DPCM	2910.60	183.20	142.17	435.60

DATA AS IT APPEARS ON YOUR MONITOR

Figure 8-17.—Example of a spreadsheet/worksheet.

The entire collection of data cells is often referred to as a matrix or an array. When you enter data, you don't need to enter it in alphabetical or numerical order; the software package will normally arrange the data in whatever sequence you desire.

Notice in figure 8-17 that each individual has only one record, and each record (row) contains seven columns (or data cells) of information. There just as easily could have been 20, 50, or 75 columns of information per record. The number of data cells is limited only by the parameters of the spreadsheet software and the amount of available memory. To give you some idea of a spreadsheet's size, the worksheet you see in figure 8-17 might be only a small portion of the entire worksheet—the amount that can be displayed at one time. There appear to be only 20 rows and 7 columns of information. However, depending upon the software package you are using, there could conceivably be as many as 8,192 rows and 256 columns of information, totaling more than 2 million data cells. A spreadsheet of this size would be equivalent to a piece of paper approximately 21 feet wide by 130 feet long. Try spreading that out on a table.

Interacting with Spreadsheet Software

Like other software packages, spreadsheet software has cursor movement keys, function keys, and commands to tell the software what to do. The following list contains some of the more common features that allow you to interact with a spreadsheet software package:

- **Cursor movement (or arrow) keys**— Allow you to move the cursor one cell at a time in one of four directions—up, down, left, or right. Other keys, such as PgUp and PgDn, move the cursor up or down one full page. Still others, when used in conjunction with other keys, allow you to move the entire worksheet in a specific direction.
- **Function key**— Allow you to display HELP screens, edit entries, display range names, enter absolute formulas, move back and forth between screens or windows, perform range and global recalculations, and so on.
- **Spreadsheet commands**— Allow you to use commands to tell the software what to do.

Features of Spreadsheet Software

Spreadsheet software packages normally include ways to do the following things:

- **Enter** labels (non-numeric data), values (numeric data), and formulas (to perform calculations, analyses, comparisons, and projections);
- **Insert** and **delete** columns and rows;
- **Copy** and **move** ranges of data cells or records from one area of a worksheet to another;
- **Erase** part or all of a worksheet;
- **Change** the way values are represented on part or all of a worksheet;
- **Split** the viewing screen to allow you to view two parts of a worksheet simultaneously;
- **Save, retrieve, rename, erase, and copy** files; and
- **Print** a worksheet.

Figure 8-18 is an example of a printed spreadsheet showing the labels, titles, and values a user entered and the values the computer calculated. Notice that all the subtotals and totals were calculated by the computer. By using spreadsheet software, you need only enter a new price when the price changes and direct the computer to recalculate the subtotals and totals.

Many of the available spreadsheet software packages will interact directly with other programs, such as database and word processing applications. Some spreadsheet packages integrate (or combine) several programs into one, such as a spreadsheet program, a graphics program, and a database management program.

DATABASE PACKAGES

Before we get too involved in database packages, let's first define what a database is. The term *database* conjures up different images for different people. However, the concept is about as nontechnical and easy to envision as a filing cabinet full of file folders. The filing cabinet and its contents are the database. The ability to retrieve the data and calculate statistics quickly and easily without regard to which folder or drawer contains the information makes the database system much more powerful than a comparable filing cabinet system.

MAGNETIC MEDIA REQUIREMENTS SPREADSHEET						
ITEM	NUMBER TO BE REPLACED	NUMBER FOR EXPANSION	TOTAL NEEDED	COST PER ITEM	TOTAL COST	
TAPES	15	30	45	27.50	1237.50	
DISKS	4	5	9	350.00	3150.00	
DISKETTES						
3 1/2"	10	30	40	1.75	70.00	
5 1/4"	10	50	60	1.30	78.00	
SUBTOTAL	20	80	100		148.00	
TOTAL	39	115	154		4535.50	

ISNP0132

Figure 8-18.—Example of a printed spreadsheet.

Let's consider a simple database, one which contains information about all enlisted personnel at your command in paygrades E-1 through E-6, including their NECs.

First, you must establish a record in the database for each individual. Conceptually, you can think of it as a file folder containing information on one particular individual. You have one file folder, or record, for each individual in your database. In this case, we want to know the individual's name, rate, social security number (SSN), division, and any NECs the individual currently holds.

Once you have defined the record, you then establish fields for each of the data elements. In this example, the fields are name, rate, SSN, division, and NECs. If you assume that each individual can have a maximum of four NECs, you will have a database containing eight fields. You now create the database by establishing the fields, specifying their size and the type of information (numeric, alphanumeric, or logical) they can contain.

Next, you enter the information for each individual into the appropriate fields. Once you create the database, you can arrange it in any logical order (by NAME, SSN, and so on). The database is normally stored on some type of secondary storage medium

(usually disk) where the information is simply held until you need it.

Now suppose you want a list of the IS1s and IS2s in the operations department with an NEC of 1234. Under a manual system, you would have to open and search through each individual's file folder, of which there could be hundreds! You would look at various entries; first for rate (or the rate field in your database file), then check to see if this person is assigned to the operations department (the division field). You would then check to see if this person has an NEC of 1234 (the four NEC fields). Finally, you would have a stack of folders for all IS1s and IS2s who are assigned to the operations department with an NEC of 1234. You could then list the names from the file folders (the records) selected.

Depending upon the number of folders you have to look through, the entire process could take hours to complete. On the other hand, you could use one of the many database packages available to obtain the same answer. The database application program, by knowing the fields in each record and the content of each field, can easily search for this information in a matter of seconds. You simply specify the selection criteria and the report format; the software does the rest—searches the database for the records that meet the criteria (IS1 or IS2, Operations Department, and NEC 1234). The

computer then displays or prints (see figure 8-19) the requested information in the format specified. You do this through the **query** and **report features** of the database package. Doesn't that beat manually searching through a drawer full of folders, which could take hours?

So, there you have it. A database is nothing more than a collection of data—many file folders or individual records containing several fields or data elements. The database is organized to allow you to retrieve, update, and have ready access to various information that can be formatted and printed as you desire. The database itself doesn't do anything; it just holds information.

Understanding Database Software

To understand how a database program works, you first need to have an understanding of certain terms. Some of the terms you are already familiar with, whereas others you may not be. These include **database**, **record**, **field**, **pointer**, **index**, **primary key**, and **secondary key**. They are defined as follows:

- **Database**— A database holds information that is related to a specific type of application—payroll, personnel, supply inventory, and so on. In this context, the term *database* is often considered synonymous with file. This is especially true

when dealing with database files. Your database input will likely be basic intelligence data.

- **Record**— A record consists of a group of related fields, all pertaining to the same subject: a person, a thing, or an event.
- **Field**— A field consists of one unit of information. A field is also referred to as a data item or a data element. It maybe alphabetic like your name (John or Jane Doe), numeric like your ZIP Code (01234), alphanumeric like your post office box or street address (P.O. Box 669 or 1234 Main St.), or logical (true/false) like on leave (true—on leave, false—not on leave).
- **Pointer**— A pointer is a data item in one record that identifies the storage location of another logically related record.
- **Index**— An index enables you to access records in a database (also referred to as database file or file) in the order of the index regardless of the physical sequence of the records in the database. You can think of indexing as sorting without having to sort. The index itself is a file. It contains a duplicate of the key field (or fields) such as account number, or name and security number, and a pointer to the actual disk record identified with this key in another permanent disk file. For example, if there are 5,000 records

OPERATIONS DEPARTMENT E5 AND E6 PERSONNEL WITH NEC, 1234			
	<u>RATE</u>	<u>NAME</u>	<u>SSN</u>
	IS2	BOAT, P. T.	555555555
	IS2	SEAMAN, A. B.	666666666
	IS1	DOE, J. A.	111111111
	IS1	DOE, J. B.	333333333
	IS1	FROST, J. R.	123456789

ISNP0133

Figure 8-19.—Example of a database report.]

in your database, and the key field happens to be SSN, the index would also contain 5,000 entries, with each entry having an SSN. It is also possible for you to have one or more secondary indexes that contain other various secondary key fields.

- **Primary key**— The primary key in a database consists of a unique identifier for a particular record and should only point to a single record in the database being indexed.
- **Secondary key**— Data are normally arranged within a database in some type of order, depending upon the contents of one or more fields. Secondary keys allow you to access the database in different ways. For example, your database might be arranged in the order the records were entered. You can then set up a secondary index (or key) by the name field, or by the social security number field. You may specify any number of secondary keys. You might index by more than one field. For example, you could index by last name within rate as we have done in figure 8-19.

Database Organization Methods/ Structures

Databases can be **list**, **hierarchical**, **network**, or **relational** in structure. The major advantage of a database is that it permits the maintenance of a related set of files or tables that can provide information to several different users. So, how do these database structures differ? you might ask. That's a good question. Read on and find out.

LIST DATABASES.— List databases link records through the use of pointers. The pointer is a data element in one record (normally the master record) that points to the actual disk location of another logically related record.

HIERARCHICAL DATABASES.— Hierarchical databases consist of elements that act in a superior-subordinate or parent-child relationship. What this means is that one element is linked to another element in the database. The **superior** element points to one or more **subordinate** elements. There can also be a subordinate of a subordinate, which will enable many hundreds of elements to be connected.

NETWORK DATABASES.— Network databases are very similar to hierarchical databases except that an element can have **one** or **more superiors**. The database management software permits the extraction of needed information from such a structure to begin with any record in the file. Although network databases are more flexible than hierarchical databases, they still have limitations. The networking scheme must be defined when the database is initially created, and information retrieval is based solely on the predefined scheme.

RELATIONAL DATABASES.— Relational databases have many advantages over network and hierarchical databases. They consist of **one** or **more tables** in which data is stored in the form of **rows** and **columns**. The main advantage of a relational database is that you (the user) can establish the relationships between the data whenever you request information. For example, you could use relation tables to link a person with his or her NECs, duty assignments, and any special qualifications. Many other relations are, of course, possible. Any relational database package normally uses an index of some sort for faster access to the data. Relational structures are a very popular database structuring approach for both mainframe and smaller computer database packages.

Using Database Software

Some of the more common operations you can expect to perform when using a database software package are as follows:

- **Create** databases;
- **Insert**, **update**, and **delete** data in a database;
- **Create** and **run** applications programs, forms, and reports;
- **Design** and **print** labels;
- **Query** the database for information;
- **Create** and **run/execute**; and
- **Import** and **export** files.

You can use function keys F1, F2, and so on, to provide help screens; to display lists of items; to design database files, queries, reports, forms, and labels; to add fields to a layout; to move or copy selected data; to enlarge or shrink fields or condition boxes; to print a quick report; to access menus for the current screen; to access macros; and so on.

Some database packages provide you with some type of control screen, like the one shown in figure 8-20. Using a control screen allows you to access a number of features. This particular control screen has six panels, each corresponding to a different type of operation in your database. Displayed across the top left-hand corner of the control screen, you see three main menus—**Catalog**, **Tools**, and **Exit**. **Catalog** provides you with options for managing catalogs and the files contained in them. A catalog is a file in itself that contains the names of related files. **Tools** provides you with a variety of utilities for accessing the disk operating system (DOS), for importing and exporting files, and for setting program parameters. **Exit** enables you to leave the control screen and go back to DOS.

Most database packages provide you with some type of **query language** that allows you to query a database to obtain answers about the contents of the database, insert new data, update information in various tables, and create views. By using various commands and control statements, you can perform arithmetic, logical, and comparison operations on the data you have selected.

UTILITIES

Software utilities further enhance the capabilities of your computer and make it run more efficiently. Once you become familiar with the system and applications software you are working with, you will want the

system to do more and do it faster and more efficiency. Utilities can satisfy some of this need for more computer power, overall performance, internal security, file and data management, and backup capabilities. Utilities strive to fill some of the voids left by applications or operating system software. For the most part, utilities are meant to work in conjunction with your existing software.

Your disk operating system (DOS) includes such utilities as COPY, SORT, FORMAT, BACKUP, RESTORE, TYPE (to print files), DIR (to list files in directories), RENAME (to rename files), CLS (to clear your monitor's screen), and many, many more. Utilities, such as spell checkers, dictionaries, thesauruses, and grammar checkers, are often included in word processing packages. Many applications programs include keyboard enhancing programs that allow you to store frequently used words and sentences and then access them with either a single keystroke or combination of a few keystrokes (also known as hot keys). Then there are mouse utilities that allow you to program the right and middle mouse buttons for particular tasks.

Although utility programs are getting easier for us to use, selecting the best one to accomplish a particular task can be somewhat difficult. If you look around to see what utilities are available, you will find there are thousands of various types on the market to choose from. To introduce you to the various types, we have

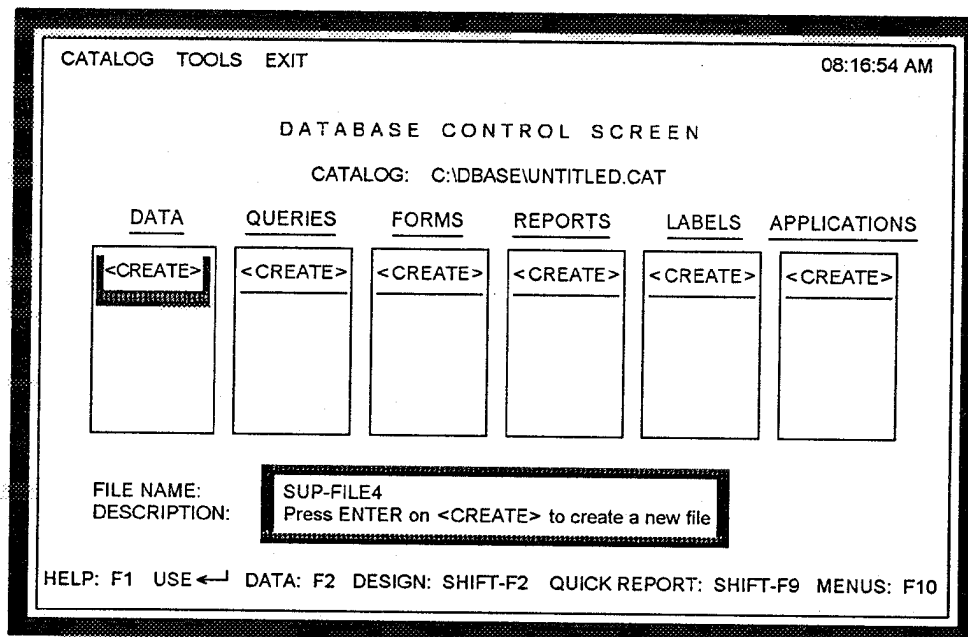

ISNP0134

Figure 8-20.—Typical control screen used with a database application.

organized the typical utility software programs into eight categories: keyboard enhancement, desktop organizer, backup, file management, file maintenance, DOS shell, printer, and virus utilities.

Keyboard Enhancement Utilities

Keyboard enhancers, as the name implies, expand the function of the PC keyboard. These programs (which are usually RAM resident programs) translate a single keystroke into user-defined macro commands. A macro consists of one instruction that represents many instructions. For example, Ctrl-Alt-C keystrokes could be simplified as the Esc key with a user-defined macro. Any string of keystrokes or characters can be stored as a macro. More importantly, once you have defined the macro, you can store it as a file for use with different applications. In short, by shortening commands and character strings, you can greatly reduce keystroke repetition.

Desktop Organizer Utilities

Desktop organizers consist of programs that emulate such things as calculators, notepads, phone directories, calendars, and appointment books. Most of these utilities are memory resident. This means they can be accessed from within other applications programs. For example, you can call up the calculator utility while you are currently working in a word processing application. An image of a calculator will “pop-up” in a small window on your monitor’s screen. You then perform the necessary calculations, and then return to the word processing application. Some desktop organizers allow you to take the resulting calculation and place it directly into the word processing document you are working on. This is referred to as “cut and paste.” Most programs included in desktop organizers also operate in this pop-up mode.

Backup Utilities

We should all be familiar with backup utilities. Disk backup utilities provide us a cost-effective way to back up a hard disk. Advanced features, such as automatic backup (backups taken at predescribed intervals), file compression (which allows more data to be placed on a diskette), and automatic disk formatting, make disk backup utilities a good alternative to the backup utilities supplied with most operating systems. Backup utilities also allow you to save your files to tape, or even to another hard disk.

File Management Utilities

As the capacities of hard disk increase, so does the need for file management utilities. Try keeping track of the files on a 420Mb hard disk without any type of file management utility. It is next to impossible. Adding to the problem can be a maze of subdirectories—originally set up to keep order—that can easily hide a file or two. File management utilities help you avoid these problems by manipulating files and directories. These include searching for files, deleting files, tagging files (to allow for file manipulation on groups of unrelated files), relocating files, and setting file attributes. In short, file management utilities provide you with a convenient way to keep hard-disk directories, subdirectories, and the files themselves organized and under control.

File Maintenance Utilities

File maintenance utilities include file recovery utilities (including backup and restore) and programs that manipulate files, such as data compression and file security programs. File recovery utilities are designed to identify, diagnose, and repair every form of data and low-level format damage on standard DOS hard disks. One of the most critical areas of file maintenance is file recovery. If you should accidentally erase a file, you can easily recover (unerase) it by using a recovery utility.

Compression utilities save disk space by reducing file size by 40 to 60 percent. Encryption utilities are designed for file security. Using one of several encryption algorithms, these utilities will encode a file so that it is readable only by reversing the encryption process. Other utilities are designed to “hide” files from the operating system, that is, the file “disappears” from the operating system and is only accessible with a password. Still others are designed to control access to files, programs, and communications devices.

DOS Shells

These utilities, called disk operating system (DOS) shells, help translate DOS codes into English words, phrases, and diagrams. They act as a liaison between you and the operating system. DOS shells display disk and file information, adding commands not available in DOS and tend to simplify the execution of standard file management commands, such as DELETE, COPY, and PRINT.

Printer Utilities

Printer utilities provide software support for the enhanced fonts and graphics found in many printers. They also provide such features as menu control for printer functions, print spooling, and printing horizontally. Printer utilities allow you to use a printer that your applications software may not support. They also allow you to make better use of your standard printer.

Virus Utilities

Virus utilities keep out unfriendly viruses that can attack computer system software. This type of software is normally designed to prevent both known and unknown viruses from invading a system, and detects and removes those already present. What is a virus? you might ask.

A virus is a series of simple instructions that have been intentionally designed by a mischievous individual to degrade or destroy your computer files. And just like any bacterial disease, a virus can spread from disk to disk. Viruses take advantage of the sequential step-by-step process that the computer follows. The virus is read into the computer via a peripheral device (tape drive, diskette drive, communication device, and so on) from a previously infected software application. The virus then inspects the first few instructions of each program until it finds a program that does not begin with the same instructions as itself. It then attaches a copy of its own instruction set to the front of the program being examined.

The spread of the virus comes from inspecting and duplicating itself. Execution of programs may seem to appear normal until the virus strikes. A virus can destroy data files and programs, depending on its design. Be particularly careful about putting new software into your computer; if it contains a virus, it can infect your other programs and data, giving you big problems.

Utilities of the Future

What can you expect to see in the future? More and more, you will see vendors combining several utilities into one package. These packages will be difficult to categorize because they will work with operating systems, application programs, and peripherals. For

example, a file maintenance utility may combine several commonly used programs, such as disk diagnostic and recovery utilities, a DOS shell, hard-disk backup, a desktop manager, and a disk optimizer (a compression utility).

So, how do you go about staying on top of the latest and greatest utility packages available? That's easy! You can learn about utility programs by reading trade magazines and software reviews. Let the experts do the legwork of evaluation for you. There are so many utilities available on the market that it would be impossible for you to do a good job of evaluating them on your own. Vendors of application software and local computer clubs are other good sources of information.

PRINTING MAPS

One of the timesaving uses of computers in the **IS** shop is for printing maps. Printing maps or charts on any type of computer-based system depends strictly on the type of system you are using. We will not go into detail on this subject because, like any computer technology, it is bound to change. However, as an introduction to the subject we will cover a few basic points.

Most mapping products available to you will be stored on CD-ROM or other high-storage-capacity disk or tape. There are currently few systems available that will allow you to print large-scale mapping products. However, you may, again depending on the software, be able to print small-scale representations of a particular area of interest. This is especially helpful if you are preparing an intelligence brief or presentation.

Always consult with the appropriate system software operating manual or system tutorial for step-by-step procedures on printing techniques.

SUMMARY

You need to know a lot more about computers than just how to operate them if you are to become proficient in their operation. To be effective, you must keep up with computer technology and terminology. You must have a good working knowledge of computer hardware components (the computer, peripherals, and accessories). You should also be able to explain and demonstrate how to use systems and applications software, not only to junior personnel but senior personnel as well.

APPENDIX I

GLOSSARY

- A**
- ABSORBED**— When light is neither transmitted nor reflected.
- ACCESS**— The ability and opportunity to obtain knowledge or possession of classified information. Access should be limited to the minimum number of persons who require the information in the normal course of their duties.
- ACKNOWLEDGEMENT**— A message from the addressee informing the originator that his or her communication has been received.
- ADP**— Automated Data Processing.
- AERIAL RECONNAISSANCE**— The acquisition of intelligence information through visual observation and/or sensory devices aboard aerial vehicles.
- AERONAUTICAL CHART**— A chart representing a given area of the surface of the Earth and used in aerial navigation. Aeronautical charts usually represent topographical features readily identifiable from aircraft and contain aeronautical data helpful in navigation.
- AIG**— Address Indicator Group.
- AIR INTELLIGENCE**— Military intelligence directly concerning air activities of an enemy, weather, order of battle, antiaircraft defenses, airfields, and target information.
- ALIEN**— Any person who is not a citizen or a national of the United States. (See definition for UNITED STATES NATIONAL.)
- ALTITUDE**— Height of a point or object above a datum plane.
- AMPHIBIOUS RECONNAISSANCE**— Reconnaissance designed to obtain detailed beach intelligence and shoreline water-depth information for a potential amphibious landing.
- ANNOTATED PRINT**— Reproduced imagery on which the interpreter has indicated details by words or symbols.
- ANNOTATIONS**— Markings placed on imagery or drawings for explanatory purposes. Annotations are used to indicate items or areas of special interest.
- APERTURE**— The opening in a lens diaphragm through which light passes.
- APPARENT HORIZON**— The visible line of demarcation between land or sea and sky.
- AZIMUTH**— The direction of a line given as an angle measured clockwise from a reference direction, usually north.
- B**
- BAR SCALE**— A graduated line on a map, plan, photograph, or mosaic used to convert map distances to actual ground distances. Also called GRAPHIC SCALE.
- BARRIER REEF**— An offshore reef separated from land by a channel or a lagoon.
- BASE, PHOTO**— The distance between the principal points of two adjacent prints of a series of vertical aerial photographs. It is usually measured on one photograph after transferring the principal point of the other print.
- BATTLE DAMAGE ASSESSMENT (BDA)**— The determination of the effect of a bomb attack on a target.
- BE**— Basic Encyclopedia.
- BEACH PHOTOGRAPHY**— Vertical and oblique coverage at varying scales to provide informa-

tion on offshore, shore, and inland areas. It covers terrain that provides the observation of beaches and primarily concerns the geological and tactical aspects of beaches.

BEARING— The situation or direction of one point with respect to another on the compass.

BIIB— Basic Imagery Interpretation Brief; a third-phase textual/graphic presentation in hard copy of a particular objective that will aid in the consumer's comprehension of the object.

BIIR— Basic Imagery Interpretation Report; a third-phase textual/graphic detailed presentation in hard copy of a particular objective that is used to communicate comprehensive and very detailed photographic intelligence information.

BLACKBODY (INFRARED)— A hypothetical object that absorbs and reflects radiation on its surface. A blackbody is also the perfect emitter. As the name implies, a blackbody can usually be approximated by black sooty surfaces.

BLAST EFFECT— Destruction or damage to surface structures or personnel by the force of an explosion on or above the ground surface. Blast effect may be contrasted with the mining effect of a projectile or charge that explodes beneath the ground surface.

BLOWUP— Photographic slang meaning "to enlarge."

BOXWOOD SCALE— A linear-measuring device used to make measurements on imagery, maps, and charts.

BRIEF— To instruct in preparation for specific operations or to make a presentation on a particular topic.

BRILLIANCE— A word meaning the brightness of color.

C

CAMERA, AERIAL— A camera specially designed for use in aircraft.

CAMERA BODY— A component of a camera housing mechanical drives and controls and linking the lens cone with the film magazine.

CAMERA, GROUND— A camera designed for use at ground level.

CAMERA MAGAZINE— The removable part of a camera that contains the exposed and unexposed portions of the film.

CAMERA, MAPPING OR SURVEYING— A camera specially designed for producing photographs to be used in surveying. The prefix "mapping" or "surveying" indicates that the camera is equipped with means for maintaining and indicating the interior orientation of photographs with sufficient accuracy for surveying purposes. A mapping camera may be either an aerial mapping camera or a terrestrial mapping camera.

CAMERA STATION— The point in space, in the air, or on the ground occupied by the camera lens at the moment of exposure.

CAMERA TYPES— A single camera or assembly of cameras that are either used for a specific purpose, or produce a specific type of photographic coverage.

CAMOUFLAGE— The disguising of a target with paint, screens, reflectors, or other devices; also, the disguise so applied.

CAMOUFLAGE DETECTION PHOTOGRAPHY— Photography using a special type of film designed for the detection of camouflage.

CARTOGRAPHY— The art of making maps.

CENTRAL MERIDIAN— A straight meridian on a world map that divides the map symmetrically (equally in half).

CEP— Circular Error of Probability.

CHART— A map designed specially for use in navigation. (*See also* AERONAUTICAL CHART and CHART, HYDROGRAPHIC.)

CHART, HYDROGRAPHIC— A hydrographic or marine map. A map of a portion of the surface of the Earth that includes navigable waters and the adjacent or included land, if any, and on which are indicated depths of waters, marine obstructions, aids to navigation, and any other information to aid the mariner in navigating. Also called NAUTICAL CHART.

CHUM— Chart Updating Manual.

CIA— Central Intelligence Agency.

CLASSIFICATION— The determination that official information requires, in the interest of national security, a specific degree of protection against unauthorized disclosure, coupled with a designation signifying that such a determination has been made.

CLASSIFICATION MANAGEMENT— A discipline which seeks to ensure that official information is classified only when necessary in the interest of national security, is properly identified, and is kept classified only as long as necessary.

CLASSIFIED INFORMATION— Official information that requires protection against unauthorized disclosure in the interest of national security and that has been classified according to the provisions of Executive Order 12356.

CLASSIFIED MATERIAL— Any matter, document, product, or substance on or in which classified information is recorded or contained.

CLASSIFIER— One who either

- has the authority to determine that official information, not known by him or her to be already classified, requires a specific degree of protection against unauthorized disclosure. He or she will designate that information as Top Secret, Secret, or Confidential; or
- determines that official information, known by him or her to already be classified by the government, is Top Secret, Secret, or Confidential, and designates it accordingly.

CLEARANCE— An administrative determination by a designated authority that an individual is eligible for access to classified information of a specific classification category.

COASTAL ARTILLERY— Artillery emplaced to protect harbors, ports, and coastlines from attack by naval gunfire and amphibious assault. Also includes shore-based artillery used offensively against enemy shipping or sited to fire across a strip of water into enemy-held territory.

COASTAL BATTERIES— Artillery with the primary role of engaging hostile enemy shipping.

COASTAL DEFENSE BATTERIES— Artillery sited to protect a shoreline from amphibious assault.

COLOR NEGATIVES— Negatives that produce color photographs; more costly to produce than black-and-white negatives.

COLOR SENSITIVITY— The sensitivity of a photographic emulsion to light of various wavelengths.

COMBAT INTELLIGENCE— Knowledge of an enemy, weather, and geographical features required by a commander in the planning and conducting of tactical operations.

COMBAT SURVEILLANCE— A continuous, all-weather, day and night systematic watch over the battle area to provide timely information for tactical ground combat operations.

COMPARATIVE COVER— Cover of the same area or object taken at different times to show any changes in detail.

COMPROMISE— A security violation that has resulted in confirmed or suspected exposure of classified information or material to an unauthorized person. Compromise is either

- Confirmed, with conclusive evidence that classified material was compromised; or
- suspected, when some evidence exists that classified material has been subjected to compromise.

CONE— The part of the aerial camera assembly that includes the lens, the between-the-lens shutter, the diaphragm, and the metal section corresponding to the bellows on other cameras. It does not include the case drive (camera body) or magazine.

CONFIRM— To classify as firm a function or target previously not so classified.

CONTACT PRINT— A print made from a negative or a diapositive in direct contact with sensitized material.

CONTINUOUS STRIP CAMERA— A camera in which the film moves continuously past an opening in the focal plane to produce a picture in one unbroken length by virtue of the continuous forward motion of the aircraft.

CONTOUR INTERVAL— The difference in elevation between adjacent contour lines.

CONTOUR LINES— An imaginary line connecting the points on a land surface that have the same elevation, the line on a map or chart representing points of equal elevation.

CONTRAST— The actual difference in density between the highlights and the shadows on a negative or positive. Contrast is not concerned with the magnitude of density, but only with the difference in densities. Also, the rating of a photographic material corresponding to the relative density difference which it exhibits.

CONTRAST FILTER— A color filter chosen to make a colored subject stand out very sharply from surrounding objects.

CONTROL— A system of accurate measurements used to determine the distances and directions or differences in elevation between points on the Earth.

CONTROL, GEODETIC— Control that takes into account the size and the shape of the Earth. Geodetic control implies a reference spheroid representing both horizontal and vertical control data.

CONVERGENCE (OPTICAL)— The angular movement of the eyes, which causes the visual axes to intersect at a point,

CONVERGENCE OF EVIDENCE— The bringing together of several types of information in order to draw a conclusion.

COORDINATES— Linear or angular quantities, indicated by numbers, that designate the position of a point in a given reference or grid system.

COORDINATES, GEOGRAPHIC— A system of spherical coordinates for describing the positions of points on the Earth. The declinations and polar bearings in this system are the latitudes and longitudes, respectively.

COORDINATES, GRID— A system of coordinates based on a map projection that describes an actual geographic position (both latitude and longitude).

COORDINATES, PHOTOGRAPH— A system of coordinates, either rectangular or polar, that describes the position of a point on a photograph.

COURSE— The direction of the intended path of an aircraft over the Earth or the direction of a line on a chart representing the intended aircraft path, expressed as the angle measured from a specific reference datum clockwise from 0 through 360°.

COVERAGE—

- a. The ground area represented on aerial imagery, photo-maps, mosaics, maps, and so forth.
- b. The extent to which intelligence information is available with respect to any specified area of interest.

COVERAGE, STEREOSCOPIC— Air photography taken with sufficient overlap to permit complete stereoscopic examination.

COVERING POWER— The capacity of a lens to give a sharply defined image to the edges of sensitized material it is designed to cover at its largest possible aperture.

CROP— To trim or cut off parts of a picture in order to eliminate superfluous portions and improve balance or composition. Usually accomplished by masking the image area during printing.

CURRENT— The mass movement of water in one direction for an extended period of time.

CURSORY SEARCH— A systematic, logical search of imagery concentrating only on areas likely to contain items of interest.

CUSTODIAN— An individual who has possession of or is otherwise charged with the responsibility for safeguarding and accounting for classified information.

CVIC— Aircraft Carrier Intelligence Center.

D

DAO— Defense Attaché Office.

DARKROOM— A room for photographic operations (mainly processing) from which light can be excluded, usually equipped with safe-lights emitting nonacting light.

DATABASE— Reference material, such as imagery, maps, charts, plots, intelligence documents, and target folders.

DATETIME GROUP (DTG)— The date and time expressed in digits and zone suffix. (Expressed as six digits followed by the zone suffix. The first pair of digits denotes the date; the second pair, the hour; the third pair, the minutes.)

DATUM— A reference element, such as a line or plane, in relation to which the positions of other elements are determined. Also called the REFERENCE PLANE or DATUM PLANE.

DATUM POINT— Any reference point of known or assumed coordinates from which calculations or measurements may be taken.

DECLASSIFICATION— The determination that classified information no longer requires, in the interests of national security, any degree of protection against unauthorized disclosure, coupled with the removal or cancellation of the classification designation.

DECLINATION— *See* VARIATION, DECLINATION, GRID; and DECLINATION, MAGNETIC.

DECLINATION, GRID— The difference in direction between true north and grid north.

DECLINATION, MAGNETIC— The angle between true north and magnetic north. The magnetic declination is different for different places and is continuous subject to change.

DECOY— Any installation or object used to mislead an enemy.

DEFENSE MAPPING AGENCY (DMA)— *See* National Imagery and Mapping Agency (NIMA).

DEPTH OF FIELD— The distance between the points nearest to and farthest from the camera that are acceptably sharp.

DESTROYED— Damaged to such an extent that nothing is salvageable. To ensure against misuse of the term, its use must be restricted to structures that are completely leveled. In the case of bridges, all spans must be dropped, and all piers must require replacement.

DETECTOR (INFRARED)— The sensitive element of the infrared sensor that responds to differences in energy incident upon it.

DIA— Defense Intelligence Agency,

DLIR— Downward-looking Infrared Radar.

DNI— Director of Naval Intelligence.

DOCUMENT— Any recorded information, regardless of its physical form or characteristics. A document includes, without limitation, written or printed material data processing cards and tapes; maps; charts; paintings; drawings; engravings; sketches; working notes and papers; reproductions of such things by any means or process; and sound, voice, or electronic recordings in any form.

DOUBLE EXPOSURE— Two exposures on a single negative, either accidentally or intentionally.

DOWNGRADE— To determine that classified information requires, in the interest of national security, a lower degree of protection against unauthorized disclosure than currently provided, coupled with changing of the classification designation to reflect the lower degree of protection.

DRY MOUNTING— A method for cementing a print to a mount by means of a thin tissue of thermoplastic material. The tissue is placed between the print and the mount, and then melted by the application of sufficient heat, leaving the print adhered to the mount.

DUAL-PURPOSE BATTERIES— Antiaircraft artillery sited to protect a coastal area from attack by air and seaborne approach and assault.

DUPLICATE POSITIVE (DP)— First-generation copy of an original negative.

E

ECHO (RADAR)— The reflection of a radio wave from an object.

EFFECTIVE AREA— For any aerial photograph that is one of a series in a flight strip, the central part of the photograph delineated by the overlap of adjacent photographs in the series.

ELECTROMAGNETIC RADIATION— Energy emitted or reflected in the form of electromagnetic waves, which include, in order of increasing wavelength, cosmic rays, X-rays, ultraviolet radiation, visible light infrared radiation, microwave radiation, and radio waves.

ELECTROMAGNETIC SPECTRUM— The total frequency range of electromagnetic radiation.

ELECTRONIC INTELLIGENCE (ELINT)— The technical and intelligence information derived from communications electromagnetic radiations emanating from other than nuclear or radioactive sources.

ELECTRONIC RECONNAISSANCE— The detection, identification, and location of non-communication electromagnetic radiations.

ELEVATION— The vertical distance from the datum, usually mean sea level, to a point or object on the surface of the Earth. Not to be confused with altitude, which refers to points or objects above the surface of the Earth.

EMISSIVITY— The ratio of radiation emitted by a surface to the radiation emitted by a blackbody at the same temperature and under the same conditions. Targets are described in terms of their apparent emissivity. The following categories are generated target descriptions and assume that a target and its background have the same emissivity:

- a. **Warm Target:** A target that is warmer than its background, will image lighter than its background on film (positive).
- b. **Hot Target:** A target that is much warmer than its background; will image much brighter than its background on the film (positive).
- c. **Cool Target:** A target that is cooler than its background; will image darker than its background on the film (positive).
- d. **Cold Target:** A target that is much colder than its background, will image much darker than its background on the film (positive).

EMULSION (PHOTOGRAPHIC)— A suspension of light-sensitive silver salt, usually silver chloride or silver bromide, in a colloidal medium, usually gelatin, used for coating photographic films, plates, or papers.

ENERGY, RADIANT— A form of energy of electromagnetic character. All light that causes photochemical reactions is radiant energy.

ENLARGEMENT (PHOTOGRAPHIC)— A negative, dispositive, or print made at a larger scale than the original.

EQUATOR— The great circle on the Earth midway between the poles and in a plane perpendicular to the Earth's axis of rotation. It is the line of 0 degree latitude.

ESSENTIAL ELEMENTS OF INFORMATION

(EEI)— A statement of the data, which must be collected and processed, regarding terrain not under friendly control or meteorological or hydrographic conditions. A commander uses EEI to make a sound decision concerning taking a course of action, conducting a maneuver, avoiding surprise, or formulating detail of a plan of operations. Essential elements are usually in the form of questions posed for the purpose of focusing the attention and activities of all collecting agencies on high-priority information needed at a particular time.

ESTIMATE OF THE SITUATION— A logical process of reasoning by which a commander considers all the circumstances that affect the military situation and arrives at a decision concerning a course of action to take in order to accomplish his or her mission.

ESTIMATED— A term used to describe a condition in which available evidence will not permit a direct measurement or in which adequate evidence was not fully exploited.

EW— Electronic Warfare.

EXPOSURE (PHOTOGRAPHIC)— The function of the duration of time and the intensity of illumination upon photographic material.

F

FALSE HORIZON— A line resembling the visible horizon but above or below it.

FALSE PARALLAX— The apparent vertical displacement of an object from its true position, when viewed stereoscopically, due to movement of the object itself or a change in the point of observation.

FAR POINT— The object farthest from the camera that is still acceptably sharp when the camera is focused at a given distance. At a given focus setting, the FAR POINT is the outer limit of the depth of field for that setting.

FATHOM— A unit of distance used for measuring sea depths, lengths of cordage, and cables. One fathom is equal to 6 feet.

FEATHEREDGE— To thin the edge of a photographic print by abrading the back surface with sandpaper or emery paper. Performed before assembling a mosaic to obtain a smooth mosaic surface.

FIELD OF VIEW— All the area in front of the lens that the angle of view includes and is imaged on the focal plane.

FILM— A thin, flexible, transparent sheet coated with light-sensitive emulsion, for use in the camera.

FILM CASSETTE— A reloaded film container that may be installed in or removed from a camera magazine in daylight.

FILM, COLOR-SENSITIVE— Film sensitive to wavelengths not only in the 400- to 500-millimicron band of the spectrum, but also to longer wavelengths. Color-sensitive film is either orthochromatic or panchromatic.

FILM, CUT— Film cut in single-exposure sheets for use in film holders and magazines.

FILM, INFRARED— Film carrying an emulsion especially sensitive to near-infrared and blue light. Blue light is cut out by use of a deep-red filter. Used to photograph through haze because of the penetrating power of infrared light and, in camouflage detection, to distinguish between living vegetation and dead vegetation or artificial green pigment.

FILTER (INFRARED SENSOR)— An optical material inserted in the infrared system in front of the detector. It limits the radiation to that between the specified wavelengths.

FILTER (OPTICAL)— An optical material used in the optical path of a camera lens to absorb a certain portion of the spectrum and prevent it from reaching the sensitized negative.

FIRM— Evidence is sufficient to permit a definite identification of a function or target.

FIX—

- a. An accurate determination of latitude and longitude.
- b. The position on a map of a point of observation obtained by surveying processes. Also, the act of determining such a position.
- c. To render a photographic emulsion permanent by removing the unaffected light-sensitive material.
- d. The position of an aircraft relative to the ground determined by terrestrial, radio, radar, or astronomical means.

FLAK— Term often applied to antiaircraft weapons or fire of such weapons.

FLAK ANALYSIS— Analytical determination of the effectiveness (theoretical or actual) of antiaircraft defense fire.

FLIR— Forward-looking Infrared Radar.

FOCAL LENGTH— The distance measured along the lens axis from the rear nodal point to the plane of best average definition over the entire field used in the camera.

FOCAL PLANE— The plane (perpendicular to the axis of the lens) in which images of points in the object field of the lens are focused.

FOCAL PLANE SHUTTER— *See* SHUTTER.

FOCUS— The point toward which rays of light converge to form an image after passing through the lens.

FORM LINES— Lines drawn to represent the shape of terrain. Unlike contour lines, form lines are drawn without regard to a true vertical datum or regular interval.

FORMAT— Actual size and shape of a negative, oscilloscope, or other medium on which an image is produced.

FORMERLY RESTRICTED DATA— Information removed from the Restricted Data category

upon joint determination by the Atomic Energy Commission and the Department of Defense that such information relates primarily to the military use of atomic weapons and that such information can be adequately safeguarded as classified defense information. Such information is, however, treated the same as Restricted Data for purposes of foreign dissemination.

FORWARD MOTION COMPENSATION (FMC)—

Compensation for the forward motion of an aircraft while ground objects are being photographed; accomplished by a device installed in certain aerial cameras. True forward motion compensation must be introduced after the camera is oriented to the flight track of the aircraft and the camera is fully stabilized (also called IMAGE MOTION COMPENSATION [IMC]).

FORWARD OBLIQUE— Oblique photography of the terrain ahead of the aircraft. (*See also* OBLIQUITY.)

FOSIF— Fleet Ocean Surveillance Information Facility.

FRAME— An individual exposure contained in a continuous sequence of imagery.

FUNCTIONAL ANALYSIS— Determination of the function of each building in a target complex.

FUSION (STEREOSCOPIC)— A mental process of combining two perspective images on the retinas of the eyes to give a mental impression of a three-dimensional model.

G

GAP (AERIAL PHOTOGRAPH)— Any space where aerial photography fails to meet the minimum coverage requirements. This might be a space not covered by photography or a space where the minimum specified overlay was not obtained.

GAUGE— The distance between the rails of a railroad.

GENERAL RECONNAISSANCE— A flight over a new area or over an area that has not been photographed recently.

GENERATION— The number of reproductive steps in which a negative or positive photographic copy is separated from the original. The original negative is the first generation; any positive made from the original negative is a second-generation copy; a duplicate negative made from a second-generation positive is a third-generation copy.

GEODESY— The science that deals with determining the size and shape of the Earth by direct measurement.

GEOGRAPHIC COORDINATES— The latitude and longitude used to locate any given point on the surface of the Earth.

GEOREF— World Geographic Reference System.

GLOSSY PRINT— A print made on photographic paper that has a shiny surface.

GNOMONIC PROJECTION— A perspective map projection on a plane tangent to the surface of a sphere in which the point of projection is the center of the sphere.

GRADATION— The range of tones from the brightest highlights to the deepest shadows.

GRADIENT— The slope of the terrain. An underwater gradient of a beach is simply the slope of the seabottom off the beach.

GRAINY— Characterized by a lack of smoothness of the silver deposit, caused by clumps or groups of particles. Excessive graininess reduces quality, especially when magnified or enlarged.

GRAPHIC SCALE— *See* BAR SCALE.

GRATICULE (INSTRUMENTS)— A scale on glass or other transparent material in focus with the eyepiece of an optical instrument for the measurement of objects.

GRATICULE (MAPS AND CHARTS)— A network of lines representing parallels of latitude and meridians of longitude.

GREAT CIRCLE— A circle on the surface of the Earth, the plane of which passes through the

center of the Earth and which divides the Earth into two equal parts. All meridians are GREAT CIRCLES, but the Equator is the only parallel that is a GREAT CIRCLE.

GREENWICH MEAN TIME (GMT)— Mean solar time at the meridian of Greenwich, England. Also referred to as “Zulu Time” or “Zebra Time.”

GRID— A system of lines superimposed on aerial photographs, mosaics, maps, charts, and other similar representations of the surface of the Earth, which permits the identification of ground locations with respect to the indicated reference system.

GRID COORDINATES— *See* COORDINATES, GRID.

GRID DECLINATION— The angular differences in direction between grid north and true north. It is measured east or west from true north.

GRID LINE— One of the lines in a grid system, a line used to divide a map into squares. East-west lines in a grid system are x-lines, and north-south lines are y-lines.

GRID, MILITARY— A network of squares made of north-south lines showing distance east of an arbitrary origin, and east-west lines showing distance north of the same reference point. The distance between grid lines is 1,000, 5,000, or 10,000 yards (or meters) depending on the scale of the map.

GRID NORTH— The upward (northward) direction of the arbitrary meridian or vertical grid lines (north-south grid lines) usually found on military maps.

GRID, PERSPECTIVE— A network of lines drawn or superimposed on a photograph.

GRID, POINT-DESIGNATION— A system of lines drawn on an aerial photograph to divide it into squares so that points on the photograph can be readily located. The lines are drawn 1.57 inches apart regardless of the scale of the photograph. This grid is used when variations of scale in the photograph make a military grid useless.

GRID, UNIVERSAL TRANSVERSE MERCATOR

(UTM)— A military grid system in which a grid network is applied to transverse mercator projections of zones on the surface of the Earth extending to 80° N and S latitudes. The segments are 6° of longitude wide, with 1° of overlap (1/2° each side). Authorized by the Department of the Army for all military maps to replace the world polyconic grid.

GROUND ELEVATION— Actual terrain elevation above mean sea level.

GROUND POSITION— The position on the Earth vertically below the aircraft.

GROUND RESOLUTION— The ground size equivalent of the smallest resolvable image and its associated space, usually expressed in feet per side.

GROUND TRACK— The line on the ground over which an aircraft travels; also referred to as the “ground track line.”

GROUNDSPEED— The actual speed of an aircraft relative to the surface of the Earth.

GUN CAMERA— A modified motion picture camera bore-sighted with fixed or free guns to record the accuracy of aircraft gunnery.

H

HACHURES— A method of showing relief (raised areas of terrain) by short, wedge-shaped marks radiating from high elevations and following the direction of slope to the lowland.

HANDLING— Preparation, processing, transmission, and custody of classified information.

HAZE— A lack of transparency of the atmosphere caused by the presence of foreign matter, such as dust, fog, or smoke.

HARBOR— A sheltered part of a body of water that provides a natural or an artificial haven for ships.

HARDSTAND— An aircraft parking area, usually paved and built to accommodate a single aircraft.

HEADING— The angular direction of the longitudinal axis of an aircraft measured clockwise from a reference point.

- a. **Compass Heading:** The reading taken directly from the compass.
- b. **Grid Heading:** The heading with reference to grid north.
- c. **Magnetic Heading:** The heading with reference to magnetic north.

HEIGHT— Attitude above the surface of the Earth.

HORIZON— In general, the apparent or visible junction of Earth and sky, as seen from any specific position. Also called the APPARENT VISIBLE, or LOCAL, HORIZON. A horizontal plane passing through a point of vision or a perspective center. The apparent or visible horizon approximates the true horizon only when the point of vision is very close to sea level.

HORIZONTAL— In a plane at a right angle to the plumb line or vertical.

HORIZONTAL INCIDENCE ANGLE— The angle at which radar energy strikes horizontal target surfaces, such as the surface of water.

HYDROGRAPHIC RECONNAISSANCE— Reconnaissance of an area of water to determine depths, beach gradients, the nature of the bottom, and the location of coral reefs, rocks, shoals, and man-made obstacles.

HYDROGRAPHY— The science of determining the conditions of water. It includes the study of the contours of the bottom, depth, shoals, channels, tides, currents, obstructions, and other features.

I

IDENTIFY— To establish the descriptive or functional name of some object or pattern detected on photography.

IMAGE— Representation of an object on any medium by optical or electronic means.

IMAGE AREA— The region enclosed by the physical outline of a ground object as it appears on a sensor recording.

IMAGE INTERPRETATION— The use of systems, techniques, or processes to analyze imagery to produce reliable and detailed information about a given area.

IMAGE INTERPRETATION KEY— Reference material designed to aid image interpreters in the rapid, accurate identification of an object from the study of its image.

IMAGE INTERPRETER— An individual trained to detect, identify, analyze, and accurately locate, with respect to a known reference, objects and activities portrayed on imagery and to determine the significance of those objects and activities.

IMAGE QUALITY— The degree of clarity of an image from the standpoint of interpretability.

IMAGERY— A group or collection of representative objects (images) of any medium (film, electronic display devices, and so forth) by optical or electronic means.

IMAGERY COVERAGE— The total ground area recorded on imagery.

IMMIGRANT ALIEN— Any person who has been lawfully admitted into the United States for permanent residence under an immigration visa.

INACTIVE— Status of an identified target or target component determined from photography to be currently not in use, although the capability for immediate use may exist.

INDUSTRIAL ANALYSIS— The examination of an industry, as depicted on imagery, to determine the function performed by each component of the industry and to assess the vulnerability of the industry to attack.

INERTIAL GUIDANCE— An onboard, self-contained, passive guidance system for vehicles in which gyros, accelerometers, and possibly a gyro-stabilized platform satisfy guidance requirements without the use of any ground-located components. Such a system is jam

proof, entirely automatic, and capable of following a predetermined trajectory.

INFORMATION— Knowledge that can be communicated by any means.

INFORMATION (INTELLIGENCE)— Unevaluated material of every description, including that derived from observation, reports, rumors, imagery, and other sources, which, when analyzed, produces intelligence.

INFRARED FILM— Film carrying an emulsion especially sensitive to near-infrared and blue light. Blue light is cut out by use of a deep-red filter. Used to photograph through haze, because of the penetrating power of infrared light, and in camouflage detection to distinguish between living vegetation and dead vegetation or artificial green pigment.

INFRARED IMAGERY— Imagery produced as a result of sensing electromagnetic radiations emitted from a given target surface in the infrared portion of the electromagnetic spectrum.

INFRARED PHOTOGRAPHY— Photography using an optical system and direct image recording on film-sensitive to near-infrared wavelengths (infrared film). Not to be confused with infrared imagery.

INFRARED RADIATION— Energy emitted or reflected in the form of electromagnetic radiation. Wavelengths of infrared radiation range from 0.72 microns to about 1,000 microns (1 millimeter) and are frequently divided, in order of increasing wavelength, into near, middle, and far infrared.

INITIAL PHOTOGRAPHIC INTERPRETATION REPORT (IPIR)— A first-phase photographic interpretation report presenting the results of the initial scan and analysis of new imagery in answer to specific requirements on the highest priority targets.

INITIAL POINT (IP)— A well-defined point, easily distinguishable visually or by means of radar, used as the starting point for a run to a target.

INTELLIGENCE— Knowledge achieved by logical analysis and integration of available data concerning one or more aspects of a given area that is immediately or potentially significant to planning.

INTELLIGENCE, BASIC— Factual intelligence that results from the collection of encyclopedic information of more or less permanent or static nature and general interest which, as a result of evaluation and interpretation, is determined to be the best available.

INTELLIGENCE CURRENT— Limited information or intelligence of all types and forms, of immediate interest and value to operating or policy staffs, which is used by them usually without delays prior to complete evaluation or interpretation.

INTELLIGENCE CYCLE— Five distinct phases— Planning and Direction, Collection, Processing, Production, Dissemination. Each phase overlaps into the other phases.

INTELLIGENCE DATA BASE (IDB)— An aggregation of finished or initially processed intelligence data, in any form or format, and from any source, which can be exploited to provide information to augment specific analysis and to validate decisions.

INTELLIGENCE, ESTIMATE— An appraisal of the element of intelligence relating to a specific situation or condition, which is normally based upon capabilities and potentialities.

INTELLIGENCE REPORTING— The preparation and conveyance of information by any means. More commonly, the term is restricted to reports prepared by the collector and transmitted to the collector's headquarters or other intelligent-producing components. Thus, even in this limited sense, reporting embraces both collection and dissemination. The term is applied to normal and special intelligent reports.

INTELLIGENCE REQUIREMENT— A statement of specific need for the production of intelligence or the collection of intelligence information and an authorized demand on a producer or collector to satisfy such a need.

INTELLIGENCE, STRATEGIC— Knowledge pertaining to the capabilities, vulnerabilities, and probable courses of action of foreign nations, needed in the planning and execution of national security measures in time of peace and in the conduct of military operations in time of war.

INTELLIGENCE TECHNICAL— Intelligence concerning technological developments that have advanced to the point of having practical application for war purposes. It includes all steps in development that follow the initial application of principle or theory for the purpose of waging war.

INTERDICTION POINT— Any point at which traffic can be interrupted, such as a cloverleaf interchange, abridge, an intersection, and a fork on highways, railways, and waterways.

INTERPOLATE— To estimate an intermediate term in a sequence.

J

JET NAVIGATION CHART (JNC)— An all-purpose chart designed to satisfy the requirements of long-range, high-speed, high-altitude aircraft for navigational purposes.

JIIK— Joint Imagery Interpretation Key. Imagery interpretation keys published as separate volumes of DIAM 57-7.

JOINT OPERATIONS GRAPHIC (JOG)— A chart designed to provide all military services with a medium-scale chart for use in many phases of joint operations.

K

KNOT— A unit of speed, equivalent to 1 nautical mile (6,076.1 feet) or 1.15 statute miles per hour.

L

LAMBERT CONFORMAL CONIC PROJECTION— The map projection of the conical type on which all meridians are represented by straight lines and the parallels are represented by arcs. Meridians appear as straight lines that converge toward a point off the top of the map.

LATERAL COVERAGE— The ground distance represented by and included in aerial imagery measured on a line perpendicular to the line of flight.

LATITUDE— Angular distance north or south of the Equator measured along a meridian.

LEGEND— A description, explanation, table of symbols, or other information printed on a map or chart to aid the user in better understanding and interpreting the map or chart.

LENS— A piece or combination of pieces of glass or other transparent material shaped to form an image by changing the direction of rays of light passing through it.

LENS ASSEMBLY— A complete unit composed of the lens element, diaphragm, and lens barrel.

LENS DISTORTION— Any deformity in an image that is a result of an aberration (defect) in a lens.

LINE, CENTER— A line extending from the true center point of overlapping aerial photos through each of the transposed center points.

LLLTV— Low-Light-Level Television.

LOAD-BEARING WALL— A wall designed and constructed to bear the compressive weight of other portions of a building above the basement floor.

LONG TITLE— A descriptive word or phrase, consisting of a name or of several words, assigned by the preparing agency to identify the subject matter of a document or a type of device.

LONGITUDE— A linear or angular distance measured east or west from a meridian (usually Greenwich) on the Earth.

M

MACH NUMBER— Ratio of the velocity of an object to that of sound in the air. (Mach 1 is considered 762 miles per hour at sea level.)

MAGNETIC DECLINATION— The angle between true (geographic) north and magnetic north (direction of the magnetic compass needle). The magnetic declination varies for different places and changes continuously with respect to time.

MAGNIFICATION (OPTICS)— The ratio of the size of an image to the size of the object.

MAP— A surface representation, at an established scale, of the physical features (natural, artificial, or both) of a part, or all, of the surface of the Earth with the orientation indicated. A map may emphasize, generalize, or omit the representation of certain features to satisfy specific requirements. Frequently the word “map” is preceded by an adjective that explains what type of information the map is designed to present.

MAP, CONTOUR— A topographic map that portrays relief by use of contour lines.

MAP DISTANCE— The measurement between two points on a map.

MAP, GRID— Two sets of parallel lines at right angles drawn on a plane surface and used as a rectangular coordinate system (a reference system) for plotting positions and scaling distances and directions in surveying and mapping. A map grid may or may not be based on a map projection. (*See also* COORDINATES, GRID; MAP PROJECTION.)

MAP, HYDROGRAPHIC— A map showing a portion of the waters of the Earth, including shorelines, the topography along the shores and of the submerged portions, and as much of the topography of the surrounding country as necessary for the purpose intended.

MAP PROJECTION— A representation, usually on a plane surface, of the parallel of latitude and the meridians of longitude of the Earth or a section of the Earth. A map projection may be established by analytical computation or may be constructed geometrically by perspective projection.

MAP, SITUATION— A map showing the tactical or administrative situation at a particular time, used for staff study or as an addition to staff reports.

MAP, SPECIAL-PURPOSE— Any map designed primarily to meet specific requirements. Usually the map information portrayed on a special-purpose map is emphasized by omitting or subordinating other information of general character that is not essential or is of less importance.

MARGINAL INFORMATION— The notations printed in the margins or borders of mosaics, plans, or especially, maps. These may include significant dates, compilation methods, a declination diagram, instructions for the use of the grid, a geographic orientation diagram, and a means for identifying adjoining sheets. Also called MARGINAL DATA.

MARKING— The physical act of showing on classified material the assigned classification, changes in classification, downgrading and declassification instructions, and any limitations on use of the material.

MEG— A prefix meaning 1,000,000. For example, megaton means 1,000,000 tons.

MENSURATION (IMAGE INTERPRETATION)— Measurement of images on film.

MERCATOR PROJECTION— A map projection in which the meridians are drawn parallel to each other and the parallels of latitude are straight lines, whose distance from each other increases with the distance from the Equator. Maps of adjacent areas made with the MERCATOR PROJECTION fit together exactly.

MERIDIAN, CENTRAL— A straight meridian on a world map that divides it symmetrically. Not all map projections have central meridians.

METER, EXPOSURE— An instrument for measuring light intensity and determining correct exposure. It is calibrated for different emulsion speeds.

MICROFICHE— A photocopy of a publication or other document on microfilm.

MILITARY GRID REFERENCE SYSTEM— A system that uses a standard-scaled grid square, based on a point of origin on a map projection

of the surface of the Earth in an accurate and consistent manner, to permit either position referencing or the computation of direction and distance between grid positions.

MINIMIZE— A communications rendition imposed by a commander to reduce or control electrical message and telephone traffic within his or her area of authority during an emergency or exercise.

MIRV— Multiple Independently-targeted Re-entry Vehicle. A guided missile that carries several warheads, each of which can be aimed at a different target.

MISSION—

- a. The objective, or the task together with the purpose, which clearly indicates the action to be taken and the reason for the action.
- b. In common usage, especially when applied to lower military units, a duty assigned to an individual or unit.
- c. The dispatching of one or more aircraft to accomplish one particular task.

MOSAIC— An assembly of overlapping aerial photographs that have been matched to form a continuous photographic representation of a portion of the surface of a planet or satellite.

MOSAIC, CONTROLLED— A mosaic made of aerial photographs corrected for scale, rectified, and laid to ground control to provide an accurate representation of distances and direction.

MOSAIC, SEMICONTROLLED— A mosaic composed of uncorrected vertical aerial photographs laid to a limited ground control.

MOSAIC, STRIP— A mosaic consisting of one strip of aerial photographs taken on a single flight.

MOSAIC, UNCONTROLLED— A mosaic composed of uncorrected prints, the detail of which has been matched from print to print without ground control or other orientation.

MOVING TARGET INDICATOR— Any radar that indicates that an object has changed position between sweeps.

MULTISENSOR— A term pertaining to an integrated system designed to record imagery from different portions of the electromagnetic spectrum in support of all-weather data-acquisition roles.

N

NADIR— The point on the ground directly below the camera lens at the time of exposure.

NADIR PHOTOGRAPH— The point at which a vertical line through the perspective center of the camera lens pierces the plane of the photography.

NAG— Net Assessment Group.

NCIS— Naval Criminal Investigative Service.

NEED TO KNOW— A determination made by a possessor of classified information that a prospective recipient, in the interest of national security, has a requirement for access to, knowledge of, or possession of the classified information in order to carry out official military or other governmental duties. Knowledge of, possession of, or access to classified information may not be afforded to any individual solely by virtue of the individual's office, position, or security clearance.

NEGATIVE— A photographic image on film, plate, or paper in which the tones are reversed.

NEGATIVE, COLOR— A photographic image on film, plate, or paper in which the colors appear as the complements of those in nature.

NEGATIVE, TITLING— Information (for example, sortie number, camera, date, and height) recorded on the negative for identification purposes.

NIMA— National Imagery and Mapping Agency.

NIMA SYSTEMS CENTER— The agency responsible for advancing the capability of producing agency

products by using soft-copy or computerized production techniques.

NIMAAC— National Imagery and Mapping Agency, Aerospace Center.

NIMAHC— National Imagery and Mapping Agency, Hydrographic Center.

NIGHT RECONNAISSANCE— The acquisition of photo coverage with conventional cameras using artificial illumination. Other sensors used are SLR and IR.

NOMINAL FOCAL LENGTH— The theoretical distance from the optical center of the lens to the film plane. This distance is the focal distance normally engraved on the barrel of the lens.

NOTAL— (Not to All.) A communications term used to indicate that a referenced message was not sent to all addressees.

NSA— National Security Agency.

NSC— National Security Council.

O

OBLIQUITY— The characteristic in wide angle or oblique photography which portrays the terrain and objects at such an angle and range that details necessary for interpretation are seriously masked or are at a very small scale, rendering interpretation difficult or impossible.

OFFICIAL INFORMATION— Information that is owned by, produced for or by, or is subject to the control of the United States Government.

OPAQUE— Not transparent or translucent not allowing light to pass through.

OPERATIONAL NAVIGATION CHART (ONC)— A preflight planning and en-route navigation chart; also used for operational planning, intelligence briefings, plotting, flight planning, and bulkhead displays.

ORDER OF BATTLE— The identification, strength, command structure, and disposition of the

personnel, units, and equipment of any military force.

ORIGINAL CLASSIFICATION— An initial determination that official information requires, in the interest of national security, a specific degree of protection against unauthorized disclosure coupled with a designation signifying that such a determination has been made.

ORIGINAL CLASSIFICATION AUTHORITY— The authority to make original classification judgments that are given specifically and in writing to an official and his or her designated assistant of the Government.

ORIGINAL NEGATIVE (ON)— The photographic image on film, plate, or paper, in which the tones are reversed. The original film from a camera.

OSIS— Ocean Surveillance Information System.

OVERLAP— The amount by which one photograph includes the area covered by another photograph, usually expressed as a percentage. The overlap between successive aerial photographs on a flight line is called FORWARD OVERLAP. The overlap between photographs on adjacent parallel flight lines is called SIDELAP.

OVERLAP, LATERAL— The term “sidelap” is preferred. (*See* OVERLAP.)

OVERLAP, LONGITUDINAL— The term “forward overlap” is preferred. (*See* OVERLAP.)

OVERLAY— A printing or drawing on a transparent or translucent medium at the same scale as a map, chart, photograph, and so forth, to show details not appearing, or requiring special emphasis, on the original.

P

PAIR, OVERLAPPING (PHOTOGRAPHIC)— Two photographs taken at different exposure stations so that a portion of one photograph appears on a portion of the other photograph. The term covers the general case and does not imply that the photographs were taken for stereoscopic examination. (*See also* STEREO PAIR.)

PANORAMA— A photograph of a wide expanse of terrain, normally taken on or near the surface of the Earth; more often a series of adjoining or overlapping photographs.

PANORAMIC AERIAL CAMERA— An aerial camera which, through a system of moving optics, scans a wide area of the terrain, usually from horizon to horizon. The camera may be mounted vertically or obliquely within the aircraft to scan across or along the line of flight.

PARALLAX— The apparent displacement of the position of a body, with respect to a reference point or system, caused by a shift in the point of observation.

PASEP— A term used in communications indicating that a reference on a message has been supplied separately to the addressee from the originator.

PETROCHEMICAL— Generally speaking, any chemical derived completely or partially from petroleum or natural gas.

PHOTO— A short form of the word “photograph” often used in place of the word “photograph.”

PHOTO BASE— The distance between the principal points of two adjacent prints of a series of vertical aerial photographs. It is usually measured on one photograph after transferring the principal point of the adjacent photograph.

PHOTO DISTANCE (pd)— The actual measurement of an object on imagery or the measurement between two points on imagery.

PHOTO INDEX— An index map made by assembling individual photographs into their proper relative positions and copying the assembly photographically at a reduced scale.

PHOTO PRODUCTION UNIT— A center for photographic processing a printing.

PHOTO SCALE RECIPROCAL (PSR)— *See* SCALE, RECIPROCAL.

PHOTOGRAMMETRY— The science or art of obtaining reliable measurements from photography.

PHOTOGRAPH— A general term for a positive or negative picture made with a camera on sensitized material or prints from such a camera original.

PHOTOGRAPH QUALITY— A result of the camera system, processing, and film handling. Good photographic quality encompasses all the criteria for good image quality with the exception of unavoidable degradations not associated with the imaging system, that is, atmospheric, snow cover, and so forth. (See *also* IMAGE QUALITY.)

PHOTOGRAPH, SPLIT-VERTICAL— Photographs taken simultaneously by two cameras mounted at an angle from the vertical, one titled to the left and one to the right, to obtain a small sidelap.

PHOTOGRAPHIC COVERAGE— The extent to which an area is covered by photography from one mission or a series of missions or in a period of time. Coverage in this sense conveys the idea of availability of photography and is not a synonym for the word “photography.”

PHOTOGRAPHIC READING— The simple identification or description of photo images without analysis of their meaning.

PHOTOGRAPHIC RECONNAISSANCE— The obtaining of information by photography, normally carried out by special aircraft.

PHOTOGRAPHIC SCALE— The relationship of a distance measured on a photograph to the corresponding ground distance, expressed as a ratio or as a representative fraction.

PHOTOGRAPHIC SORTIE—

- a. One flight by one aircraft for the purpose of performing aerial photography.
- b. All the photographs obtained by one aircraft on one photographic mission.

PHOTOGRAPHY— The art or science of producing images on light-sensitive surfaces by the chemical or actinic action of light; also any group or collection of such images (photographs).

PHOTOMAP— A single photo, composite, or mosaic showing coordinates and adequate marginal information normally reproduced in quantity.

PHOTOSENSITIVE— A term used to describe substances whose chemical composition is altered by the action of light.

PILOT'S TRACE— An annotated map or overlay compiled with the assistance of the pilot of a reconnaissance mission. It contains such information as ground track of the reconnaissance aircraft, sensor designation, locations of sensor operation, indicated altitudes at specified checkpoints, recorded times at specified checkpoints, and estimated cloud cover observed along the line of flight.

PINHOLES— Minute (tiny) transparent spots in negatives that show up as black spots in prints, most commonly caused by dust on the film.

PLOT— A graphic representation on a map or overlay of the extent of imagery coverage.

POL— A broad term that includes all petroleum products used by the armed forms. It originated as an abbreviation for the British terms petrol, oil, and lubricants.

POLAR STEREOGRAPHIC PROJECTION— This projection is made on a plane tangent to the Earth at either pole with the pole appearing in the middle of the map. The meridians appear as straight lines radiating from the pole, and the parallels appear as circles around the pole. Used for polar navigation.

PORT— That part of a harbor that supports maritime trade.

POSITION— The location of a point with respect to a reference system, such as a geodetic datum. The coordinates that define such a location. The plane occupied by a point on the surface on the Earth. Often construed as a horizontal position when elevations are considered separately.

POSITIVE— An image having approximately the same rendition of light and shade as the original subject.

POSSIBLE— In intelligence work, a term used to qualify a statement made under renditions in which some evidence exists to support the statement. This evidence is sufficient to warrant mention, but insufficient to warrant assumption as true.

POST-STRIKE RECONNAISSANCE— Missions designed to gather information used to measure the results of a strike.

PRESTRIKE RECONNAISSANCE— Missions flown to obtain information about known targets for use by the strike force. PRESTRIKE RECONNAISSANCE is also very important in the evaluation of post-strike reconnaissance.

PRIME MERIDIAN— The meridian of longitude zero degrees, used as the origin for measuring longitude. The meridian of Greenwich, England, is almost universally used for this purpose.

PROBABLE— A term used to qualify a statement made under conditions in which the available evidence compels that the statement be assumed to be true until there is further evidence of confirmation or denial.

PROJECTION, TRANSVERSE (MAP)— A map projection in which the projection axis is rotated 90° with respect to the Earth. Also used to describe cases where a rotation through any angle has been made.

PROJECTOR— An optical instrument that throws the image of a negative or print upon a screen or other viewing surface, usually at a larger scale.

PSEUDOSTEREOSCOPY— An impression of three-dimensional relief derived by means of binocular vision and the use of identical images.

PULSE LENGTH— The length of time a radar transmitter is energized during each pulse.

PULSE-REPETITION FREQUENCY (PRF)— The number of radar pulses that occur each second.

R

RADAR— A derivative of the term “Radio Detecting and Ranging.” It is the science of locating and/or identifying distant objects by means of radio techniques.

RADARGRAMMETRY— The science or art of obtaining reliable measurements from radar presentations.

RECONNAISSANCE— A mission undertaken to obtain, by visual observation or other detection methods, information about the activities and resources of an enemy or potential enemy; or to secure data concerning the meteorological, hydrographic, or geographic characteristic of a particular area.

RECONNAISSANCE PHOTOGRAPHY— Aerial photography taken primarily for purposes other than making maps, charts, or mosaics. It is used to obtain information on the results of bombing, or on enemy movements, concentrations, activities, and forces.

REFRACTION— The change of direction of a ray of light, sound, heat, or the like, in passing from one medium into another in which the speed of propagation differs.

RELIEF— Differences in elevation on the surface of the Earth. Contour lines are used on maps to show RELIEF.

REPRESENTATIVE FRACTION (RF)— The relationship between map or image distance and ground distance expressed as a fraction (1/25,000) or as a ratio (1:25,000). Also called SCALE.

RESTRICTED DATA— All data (information) covering

- the design, manufacture, or use of atomic weapons;
- the production of special nuclear material; or

- the use of special nuclear material in the production of energy, but not to include data declassified or removed from the Restricted Data category according to Section 142 of the Atomic Energy Act.

RETICLE— A mark, such as a cross or system of lines lying in the image plane, of a viewing instrument used singularly as reference marks or as one of pair forming a floating mark.

RHUMB LINE— A line that has constant bearing on the Earth.

ROUTE PHOTOGRAPHY— Aerial imagery taken over designated routes and normally used in the construction of target folders in order to supply checkpoint photography to the strike pilot.

RPV— Remotely Piloted Vehicle; a term used to identify an unmanned, airborne reconnaissance vehicle.

RRA— Radar Return Analysis.

RSAC— Radar Significant Analysis Code.

RSPL— Radar Significant Powerlines.

S

SCALE— The ratio of a distance measured on a map, photograph, or mosaic to the corresponding distance on the ground.

SCALE, GRAY— A term used to describe the various tonal graduations on an imagery recording.

SCALE, RECIPROCAL— The reciprocal of the representative fraction (RF); for example, if the RF is 1:10,000, the scale reciprocal is 10,000.

SCAN— A rapid viewing of the imagery from a mission in order to report information on known targets and on new targets of significance.

SCANNER (INFRARED)— An optical-mechanical image-forming device that receives electromagnetic radiations from objects during successive scans across the plane of the object. It converts the radiation to electrical signals that subsequently modulate the output of light from a recording device to form a photographic image

of the relative levels of radiation in the scanned scene.

SEARCH MISSION— Aerial reconnaissance by one or more aircraft dispatched to locate an object or objects known or suspected to be in a specific area.

SECURITY— A protected condition of classified information that prevents unauthorized persons from obtaining information of direct or indirect military value. This rendition results from the establishment and maintenance of protective measures that ensure a state of inviolability from hostile acts or influences.

SECURITY VIOLATION— Any failure to comply with regulations relative to the security of classified material.

SELECT PRINT— A photographic copy singled out by the interpreter to be printed from a negative for distribution.

SENSITIVE COMPARTMENTED INFORMATION (SCI)— All information and materials bearing special intelligent community controls indicating restricted handling within intelligence collection programs and their end products. These controls are formal systems of restricted access established to protect the sensitive aspects of foreign intelligence programs.

SERE— Survival, Evasion, Resistance, and Escape.

SHADOW (RADAR)— The area of no return on a radar receiver resulting when an intervening object prevents radar energy from striking an area.

SHORT TITLE— A brief, identifying combination of words, letters, or numbers applied to specific items of classified material.

SHUTTER— The mechanism of a camera which, when set in motion, permits light to reach the sensitized surface of the film or plate for a predetermined length of time.

SIDE-LOOKING AIRBORNE RADAR (SLAR OR SLR)— An airborne radar that produces an image of a portion of the surface of the Earth by means of one or more antennas viewing at

approximately right angles to the longitudinal axis of the aircraft.

SIGNATURE— The physical feature or pattern of physical features by which a target can be recognized on imagery.

SLANT RANGE (SR)— The distance measured along the line of sight from the aircraft to an object on the ground.

SPATIAL RESOLUTION (INFRARED)— The ability of a system to separate the images of two lines at a given distance.

STEREO PAIR— Two photographs with sufficient overlap and consequent duplication of detail to make possible stereoscopic examination of an object or an area common to both.

STEREOGRAPHIC COVERAGE— Photographic coverage with overlapping photographs to provide a three-dimensional presentation of the object. Sixty percent overlap is considered normal.

STEREOSCOPE— A binocular optical instrument used to view two properly oriented photographs or diagrams to obtain the mental impression of a three-dimensional view.

STEREOSCOPIC BASE— The distance and direction between complementary image points on a stereoscopic pair of photographs.

STEREOSCOPIC IMAGE— That mental impression of a three-dimensional object that results from stereoscopic vision.

STEREOSCOPIC VISION— The application of binocular vision that enables the observer to view an object simultaneously from two different perspectives (as two photographs taken from different camera stations) to obtain the mental impression of a three-dimensional model.

STEREOSCOPE— The science or art that deals with three-dimensional effects and the methods by which these effects are produced.

STRIKE— A concerted air attack on a single objective.

STRUCTURAL ANALYSIS— Determination of the essential physical characteristics of each building in a target complex

STRUCTURAL DAMAGE— Destruction, displacement, severance, or distortion of structural members (trusses, beams, and columns) to such a degree that the damaged members cannot be repaired. The latter condition is considered to exist if the above types of damage to structural members can be identified by the imagery interpreter.

STRUCTURAL FRAMING— The skeletal construction that gives shape and strength to a building.

SUPERFICIAL DAMAGE— Damage that can be repaired without affecting the main structure and without necessitating replacement of main frame members.

SUPIR— Supplemental Photo Interpretation Report; a second-phase review of imagery acquired from a mission.

SURVEILLANCE— The systematic observation of air, surface, or subsurface areas by visual, electronic, photographic, or other means for intelligent purposes.

SWEEP LENGTH— The length of a perpendicular measured from the center of the ground track to the outermost extent of the recorded imagery.

SYNCHRONOUS FILM SPEED— The movement of the film in a camera at the same speed and in the same direction as a moving object is moving, thus eliminating image motion.

T

TACTICAL AERIAL RECONNAISSANCE— Airborne data collection and the subsequent processing, interpretation, and distribution of derived intelligence concerning terrain, weather, an enemy's force structure, movement, strength, disposition, capability, actual or potential lines of communication, and other resources that could affect the tactical situation.

TACTICAL PILOTAGE CHART (TPC)— A chart used to supplement information contained on

- smaller scale charts, such as the ONCs and JNCs.
- TARGET (INTELLIGENCE)**— A specified installation, object, activity, or geographic area of intelligence interest.
- TARGET ACQUISITION**— The detection, identification, and location of a target in sufficient detail to permit the effective use of weapons.
- TARGET ANALYSIS**— An examination of potential targets to determine military importance, priority of attack, and weapons required to obtain a desired level of damage or casualties.
- TARGET AREA**— The environs of a target that might reasonably encompass associated activity.
- TARGET BRIEF**— Consolidated reference, including photos, maps, and collateral materials, on a given target for presentation to an attack crew.
- TARGET COMPLEX**— A geographically integrated series of target concentrations.
- TARGET DOSSIER**— A group of documents containing detailed information about a target.
- TARGET SIGNATURE**— Collectively, those unique characteristic that define or identify a target.
- TARGET SYSTEM**— A group of targets so related that their destruction will produce some particular effect desired by the attacker.
- TARPS**— Tactical Air Reconnaissance Pod System.
- TDI**— Target Data Inventory.
- TECHNICAL INTELLIGENCE PHOTOGRAPHY**— Photography (usually ground) of enemy equipment, material, and installations with complete camera data.
- TEL**— Transporter-Erector-Launcher.
- TELAR**— Transporter-Erector-Launcher and Radar.
- TERRAIN**— An area of ground considered as to its extent and topography.
- TERRESTRIAL PHOTOGRAPHY**— The taking of photographs by a camera located on the ground; sometimes called GROUND PHOTOGRAPHY.
- TEXTURE**— In a photo image, the amount of change and arrangement of tones. Some terms for texture are fine, medium or coarse, and striped or mottled.
- THERMAL CAPACITY (INFRARED)**— A measure of how much heat an object will hold.
- THERMAL CONDITION (INFRARED)**— The transfer of thermal energy from one part of an object to another.
- THERMAL CONDUCTIVITY (INFRARED)**— A measure of how well a body can transfer heat.
- THERMAL CONVECTION (INFRARED)**— The transfer of thermal energy from one place to another by the actual motion of materials.
- THERMAL IMAGERY (INFRARED)**— Imagery produced by measuring and recording electronically the thermal radiation of objects.
- THERMAL RADIATION (INFRARED)**— The continual radiation of energy from the surface of all objects above absolute zero temperature.
- THERMAL SHADOW**— The silhouette of an object that appears on infrared imagery after the object has been removed sometimes called a ghost.
- THERMAL SIGNATURE**— The amount and location of heat emitted from an object.
- TIDE**— The vertical rise and fall of the ocean level caused by the gravitational force between the Earth and the Moon (and to a lesser extent, the Earth and the Sun).
- TIME OVER TARGET (TOT)**— That time when an aerospace vehicle is positioned over a predetermined point on the ground.
- TIME, STANDARD CIVIL**— Mean solar time based upon the transit of the sun over a certain specified meridian, called the time meridian, and adopted for use over a considerable area. With few exceptions, standard time is based upon

some meridian which differs by a multiple of 15° from the meridian of Greenwich, England. Civil time begins at midnight.

TIP— The term “y-tilt” is preferred.

TITLE BLOCK— A space on a mosaic, map, or plan devoted to identification, reference, and scale information.

TITLING— Information lettered on photographic negatives in accordance with service regulations. Supplementary information may be added for special purposes. This information should be placed so that it does not obscure the photo detail.

TONE— Noticeable variation in shades from black to white.

TOPOGRAPHY— Features of the surface of the Earth considered collectively as to form. A single feature (such as a mountain or valley) is called a topographic feature. Topography is subdivided into hypsography (relief features), hydrography (water and drainage features), and culture (man-made features).

TRANSLUCENT— Permitting light to pass through but diffusing it so that persons, objects, and so forth, on the opposite side are not clearly visible.

TRANSMISSION— Any movement of classified material from one place to another.

TRANSPARENCY— A photographic print made on a transparent base and viewed by transmitted light.

TRIANGULATION— An operation in surveying that consists of extending the survey from a measured baseline by measuring the angles in a network of triangles, at least one of which includes the baseline as one of its sides.

TRUE HORIZON— The plane perpendicular to the vertical axis and passing through the rear nodal point of the lens of a camera.

TUBE MAGNIFIER— A magnifying glass set in a tubular frame, with the eyepiece at the upper end and a graduated scale at the base. A

linear-measuring device used to measure imagery.

U

UNIDENTIFIED (U/I)— Evidence is insufficient to permit designation of the function, type, or name of a target to the degree needed in the context of the intelligence requirement.

UNITED STATES AND ITS TERRITORIES— The 50 States; the District of Columbia; the Commonwealth of Puerto Rico; the Territories of Guam, American Samoa, and the Virgin Islands; the Trust Territory of the Pacific Islands; and the Possessions, Midway and Wake islands.

UNITED STATES NATIONAL— A person born in an outlying possession of the United States on or after the date of formal acquisition of such possession; or

- a person born outside the United States and its outlying possessions of parents, both of whom are nationals, but not citizens of the United States, and have had a residence in the United States or one of its outlying possessions prior to the birth of such person; or
- a person of unknown parentage found in an outlying possession of the United States while under the age of 5 years, unless shown, prior to reaching the age of 21 years, not to have been born in such outlying possession. (For the purposes of this regulation, U.S. Nationals are included in the use of the term “U.S. citizens.”)

UNIVERSAL REFERENCE GRID (URG)— A grid system used to define point locations on photography as linear coordinate positions.

UNIVERSAL TRANSVERSE MERCATOR (UTM) GRID— *See* GRID, UNIVERSAL TRANSVERSE MERCATOR.

UPGRADE— A change of the classification designation of already classified information to a higher level based on a determination that the information requires, in the interest of national security, a higher degree of protection against

unauthorized disclosure than that provided by its current classification designation.

V

VANISHING POINT— The image on the plane of the photograph of the point toward which a system of parallel lines in the object space converge (meet).

VARIATION— The angular difference between magnetic north and true north measured east or west from true north.

VIADUCT— A bridge that carries a roadway or railway over a very wide or deep depression.

VIEWFINDER—

- a. A camera attachment that shows, on a viewing lens, the image thrown by the camera lens on the platen of the camera.
- b. An aerial sighting instrument with a grid of crosshairs on a ground-glass screen, usually mounted behind the camera.

VULNERABILITY ANALYSIS— The study of an industrial complex to determine the points at which maximum effect can be achieved with the available weapons.

W

WAC— World Area Code.

WASTE— A general term for such matter as spoil, tailing, refuse, garbage, ashes, rubbish, sewage, and material discarded from any industrial process. In nuclear terminology, this maybe the

refuse by-product of a chemical separation or reactor process.

WEFT— Wings, Engines, Fuselage, and Tail. A system used to identify aircraft on imagery.

WHARF— A structure that parallels the shoreline and provides berthing at its face.

X

X-AXIS— A horizontal axis in a system of rectangular coordinates; the line on which distances to the right or left (east or west) of the reference line are marked, especially on a map, chart, or graph.

Y

YAW— An angular displacement about the vertical axis of an aircraft.

Y-AXIS— A vertical axis in a system of rectangular coordinates; the line on which distances above or below (north or south of) a reference line are marked, especially on a map, chart, or graph.

Y-PARALLAX— The difference between the perpendicular distances of the two images of a point from the vertical plane containing the air base. The existence of y-parallax is an indication of tilt in either or both photographs or a difference in flying height and interferes with stereoscopic examination of the pair.

Z

ZENITH— The point in space directly above the observer (opposite of nadir).

APPENDIX II

THE UNITED STATES INTELLIGENCE ORGANIZATION

INTRODUCTION

As an IS engaged in intelligent work, you must be aware of the wide variety of sources of information available to you and must not limit your information to that available from national security agencies alone. With proper liaison, a vast reservoir of information is available from agencies of the Federal Government, much of it in the form of documents issued by these agencies for specific purposes. The old saying that "everything comes to him who waits" certainly does not apply to the Intelligence Specialist. You must learn about the existence of information and request it through channels or obtain it through liaison from other sources. This appendix deals with the United States intelligence organization and its various agencies. Appendix III deals with the primary foreign intelligence agencies.

UNITED STATES ORGANIZATION FOR NATIONAL SECURITY

Intelligence is extremely important to our government and its armed forces as they work together to promote and maintain the security and welfare of the United States in its relations with other nations. These relations are based on our foreign and military policies. To be sound and constructive, U.S. military and foreign policy must be based upon fact and realism. Many of the facts needed to support these policies are provided by our intelligence organizations.

In recent years, the United States assumed additional responsibilities on world and regional bases under various pacts and treaties. Discharging our responsibilities under these agreements became a part of our national policy. To cope with these additional responsibilities, the United States had to reorganize and expand the agencies responsible for formulating and directing plans and policies relating to national security. The organizations that produce the intelligence to support these new and expanded

agencies also had to change, some frequently, in order to accomplish their assigned tasks.

NOTE: You should keep in mind that minor organizational changes occur frequently in most government agencies and that published organizational charts or descriptions given in this appendix represent the situation that existed at the time this TRAMAN was written.

Since the U.S. intelligence community is within the executive branch of the government, the President is responsible for managing it. The National Security Council, chaired by the President, defines long-term U.S. national requirements for intelligence. The National Foreign Intelligence Board (NFIB), with the Director of Central Intelligence as its chairman, amplifies and publishes these requirements as guidance for all U.S. requirements control authorities.

NATIONAL SECURITY COUNCIL (NSC)

The NSC was created by the National Security Act of 1947 and is composed of officials specifically designated by statute. It is the only division of the Executive Office of the President that has duties and responsibilities for intelligence. The voting members of the NSC are the President of the United States, the Vice President, the Secretary of State, and the Secretary of Defense. In addition to these statutory members, the Special Assistant to the President for National Security and the civilian Executive Secretary sit as officials. Further, the NSC has two advisers who regularly sit with the members. They are the Chairman of the Joint Chiefs of Staff and the Director of the Central Intelligence Agency. The President acts as chairman of the council.

Stated briefly, the function of the NSC is to advise the President concerning how to integrate domestic, foreign, and military policies relating to national security so that the military services and the other departments and agencies of the government

may cooperate more effectively in matters involving national security. To ensure an adequate intelligence base for these deliberations, the 1947 Act also created the Central Intelligence Agency (CIA).

The NSC, subject to the direction of the President, has the following additional duties:

- Assess the objectives, commitments, and risks of the United States in relation to our actual and potential military power in order to make recommendations concerning national security to the President.
- Consider policies on matters of common interest to the departments and agencies of the government concerned with the national security, and to make recommendations to the President.

DEPARTMENT OF DEFENSE (DOD)

The DOD, created by the National Security Act of 1947, is the successor to the National Security Establishment. The DOD was established as an executive department of the government by the National Security Act Amendment of 1949 with the Secretary of Defense (SECDEF) as its head. The Secretary is the principal defense policy adviser to the President and is responsible for the formulation of general DOD and defense-related policy.

The DOD is composed of the following agencies:

- Office of the Secretary of Defense;
- Each of the military departments and the military services within those departments;
- The Joint Chiefs of Staff;
- The unified and specified commands; and
- Other offices, agencies, activities, and commands that may be established or designated by law, the President, or the Secretary of Defense.

Office of the Secretary of Defense

Within the office of the SECDEF, the Deputy Under Secretary of Defense for Policy is the

principal staff adviser for matters relating to overall international security policy and political/military affairs.

The Assistant Secretary of Defense for Command, Control, Communications, and Intelligence (C³I) is the principal staff assistant and adviser to the SECDEF for C³I, information management, counterintelligence, and security countermeasures matters, including warning reconnaissance, intelligence and intelligence-related activities conducted by the DOD.

Joint Chiefs of Staff (JCS)

As the senior members of their respective services, the Joint Chiefs set policy for their services and advise the SECDEF in the use and maintenance of the military. The JCS consists of the following individuals:

- Chairman;
- Vice Chairman;
- Chief of Staff (COS), U.S. Army;
- Chief of Naval Operations (CNO);
- Chief of Staff (COS), U.S. Air Force; and
- Commandant of the Marine Corps.

Supported, subject to the authority of the Chairman, by the Joint Staff, they constitute the immediate military staff of the SECDEF. The Chairman is the principal military adviser to the President, the NSC, and the SECDEF. The other members of the Joint Staff are the senior military officers of their respective services and also serve as advisers to the President, the NSC, and the SECDEF.

THE INTELLIGENCE COMMUNITY

To take advantage of the wide range of sources available, you must understand the general structure of the intelligence community or network. As used here, the intelligence network denotes the agencies of the Federal Government that collect information and process it into intelligence. This intelligence network includes the Central Intelligence Agency

(CIA); the intelligence elements of the Department of State; Defense Intelligence Agency (DIA); Army, Navy, Air Force, and Marine Corps; the National Security Agency (NSA); and the Federal Bureau of Investigation (FBI).

Intelligence may be the sole business of an agency, such as the Defense Intelligence Agency or the Office of Naval Intelligence (ONI). Intelligence may also be a function that an agency must perform in order to support some wider and more encompassing functions, such as those of the Department of Defense or the Department of the Navy.

CENTRAL INTELLIGENCE AGENCY (CIA)

The CIA was established by the National Security Act of 1947 to replace the World War II *Office of Strategic Services*. Officially supervised by four congressional committees, it is forbidden by law to exercise any police, subpoena, or law enforcement powers, or internal security functions in the U.S.

The head of the CIA is appointed by the President, with the advice and consent of the Senate. As Director of Central Intelligence (DCI), he is the principal intelligence adviser to the President and to the NSC on all matters relating to national security. In performing this duty, the DCI has access to the intelligence produced by or available to all departments and agencies of the government. Consequently, the DCI must make recommendations to the NSC concerning the coordination of the various government agency intelligence activities that relate to national security.

The duties of the DCI, in more specific terms, are as follows:

- Advise the NSC in matters concerning intelligence activities of government departments and agencies that relate to national security;
- Make recommendations to the NSC for coordinating intelligence activities of government departments and agencies that relate to national security;
- Correlate and evaluate intelligence relating to national security, and provide for appropriate dissemination of such intelli-

gence within the government, using, where appropriate, existing agencies and facilities;

- As directed by the NSC, perform for existing intelligence agencies services of common concern that can be more efficiently accomplished centrally; and
- At the direction of the NSC, perform, from time to time, other functions and duties related to intelligence that affect national security.

The DCI also serves as the chairman of the National Foreign Intelligence Board (NFIB). The NFIB coordinates and supervises the major American intelligence activities and exercises supervisory control over every other security system.

NATIONAL SECURITY AGENCY (NSA)

The NSA was created by a Top Secret directive signed by President Truman in 1952. Congress granted the NSA special protection under the National Security Act of 1959. Under the Act, the NSA was exempt from having to provide any information concerning its mission and activities or the names, numbers, and ranks of its employees.

True to the nature of its mission, the NSA maintains tight security with very little information provided for public disclosure. The agency does not publish information pamphlets or provide any information on its activities, organization, or staff. The NSA has complete responsibility for U.S. communications security (COMSEC) activities, signals intelligence (SIGINT) production, and counterintelligence processing. It also provides SIGINT support to the various authorized DOD elements.

DEFENSE INTELLIGENCE AGENCY (DIA)

The DIA was established as an agency of the Department of Defense by DOD Directive 5105.21 of 1 August 1961, under the provisions of the National Security Act of 1947. It operates under the direction, authority, and control of the Secretary of Defense. The chain of command for the DIA extends from the Secretary of Defense, through the Joint Chiefs of Staff (JCS), to the Director. The Director of the DIA serves as the J-2 (or intelligence) arm of the JCS, and provides all the

support necessary to fulfill the national-level intelligent needs of the Washington community. This is accomplished through the National Military Joint Intelligence Center (NMJIC). The NMJIC is the central body for managing national intelligence operations. The NMJIC focuses mainly on global Indications and Warning (I&W), operational intelligence, national targeting support, production and database management.

The flow of intelligence from the DIA to the unified commands normally follows command channels, but direct communications are authorized between the DIA and military intelligence resources at any level of the DOD.

The purpose of the agency is to coordinate the intelligence efforts of the Navy, Army, Air Force, and Marine Corps. It provides military intelligence for national foreign intelligence and counter-intelligence products, coordinates all DOD intelligence collection requirements, manages the Defense Attaché System (DAS), and supports the JCS. Information gathered by the service agencies, such as assessments of the military strength of friendly and unfriendly countries, is processed through the DIA to the CIA, where the information can then be evaluated.

NAVAL INTELLIGENCE

Naval intelligence is a system of personnel, procedures, equipment, and facilities, both afloat and ashore, that supports both naval and joint operations. It is embedded in all major echelons of command and deployed continuously with naval forces. Naval intelligence encompasses not only dedicated intelligence elements, such as a Marine Radio Battalion, but also those having other primary functions as well. An example of the latter is a destroyer at sea sending a surface contact report. In fact, naval forces are unique in that threat intelligence collection capabilities are resident in many of our weapons platforms. At the tactical and operational levels of warfare, intelligence collection is just one more capability of ships, submarines, and aircraft.

Naval intelligence is a part of the joint intelligence architecture in current theaters of operations, connecting naval forces to theater joint intelligence centers, national intelligence agencies, service intelligence centers, and cooperative foreign governments.

The naval intelligence organization is headed by the Director of Naval Intelligence (DNI), as shown in figure AII-1. The DNI is responsible for performing the intelligence functions for the Chief of Naval Operations (CNO). The CNO is required by Navy Regulations to “collect, evaluate, and disseminate all types of intelligence information required within the Naval Establishment.”

Office of Naval Intelligence

On 23 March 1882, the Secretary of the Navy signed General Order 292, which established the Office of Naval Intelligence (ONI) in the Bureau of Navigation “to collect and record such naval information as may be useful to the Department of the Navy in wartime as well as in peace.”

The Office of Naval Intelligence has historically been associated with all aspects of U.S. Navy intelligence, including

- the Naval Attaché System;
- naval intelligence postgraduate and language schools;
- amphibious intelligence, air intelligence, and fleet intelligence centers;
- operational intelligence;
- commerce and travel;
- photographic and scientific intelligence;
- security policy;
- telecommunications;
- censorship;
- counterintelligence; and
- investigations.

The maritime needs of the U.S. armed forces are served by the ONI and the National Maritime Intelligence Center (NMIC). The mission of the ONI is to provide timely and reliable maritime intelligence products and services in support of the national defense. The ONI provides intelligence and foreign liaison support to SECNAV, CNO, and

N2/PENTAGON ORGANIZATION

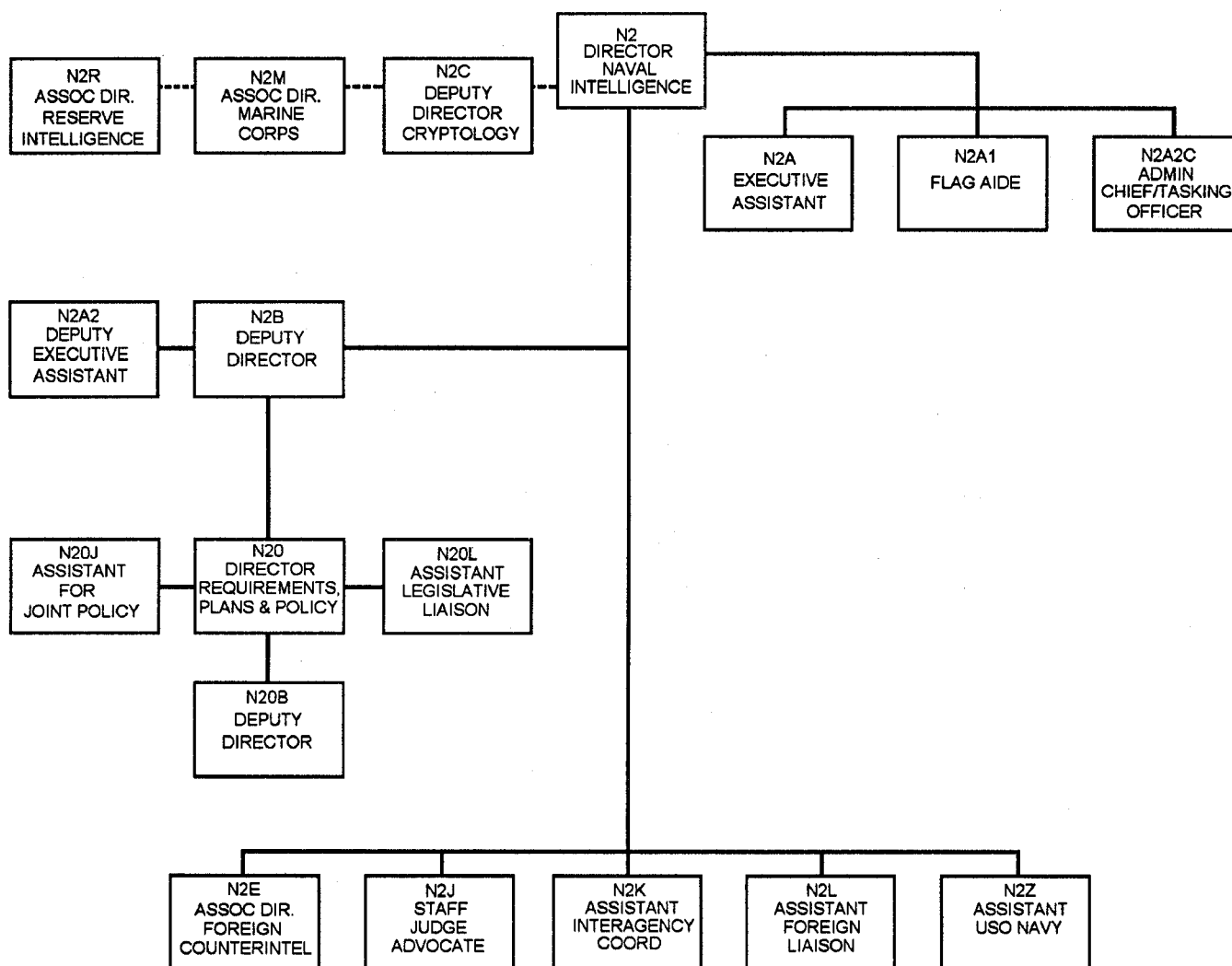

ISNP0091

Figure AII-1.-DNI organization chart.

other Navy elements, including fleet assets. The ONI represents Navy interests within the defense and national intelligence communities, and serves as the sponsor for certain unique national defense and maritime intelligence programs.

The ONI is charged with directing and managing maritime intelligence activities to fulfill intelligence requirements and responsibilities assigned by the DCI as a member of the national intelligence community, and by the CNO in support of the Department of the Navy (DON). The ONI also

directs and coordinates intelligence collection, production, dissemination, and other activities necessary to satisfy the requirements of operating forces, the DOD, the DIA, the National Command Authority (NCA), and other government agencies.

ONI currently encompasses eight distinctive directorates. They include:

- **ONI-1**— Human Resources;
- **ONI-2**— Intelligence;

- **ONI-3**— Services;
- **ONI-4**— Installation Management
- **ONI-5**— Security;
- **ONI-6**— Collections;
- **ONI-7**— Systems; and
- **ONI-8**— Resource Management.

Specific functions that apply to supporting operations are discussed below. See figure AII-2 for the ONI organization chart.

ONI-1, the Human Resources Directorate, manages military and civilian personnel, manpower,

Reserve affairs, career development, and training programs within the ONI and the Navy intelligence community. Of particular importance is its role as the IS rating technical adviser and rating coordinator.

ONI-2, the Intelligence Directorate, performs substantive maritime intelligence analysis and production over the entire range of areas connected to the Navy's responsibilities during both war and peace, especially in support of expeditionary forces. These areas include characteristics and performance data, tactics, and operational doctrine on non-U.S. maritime platforms and systems that U.S. war-fighters may encounter around the world. Analysis and production also include any areas that may directly affect U.S. national policy or assets, such as piracy or maritime terrorism.

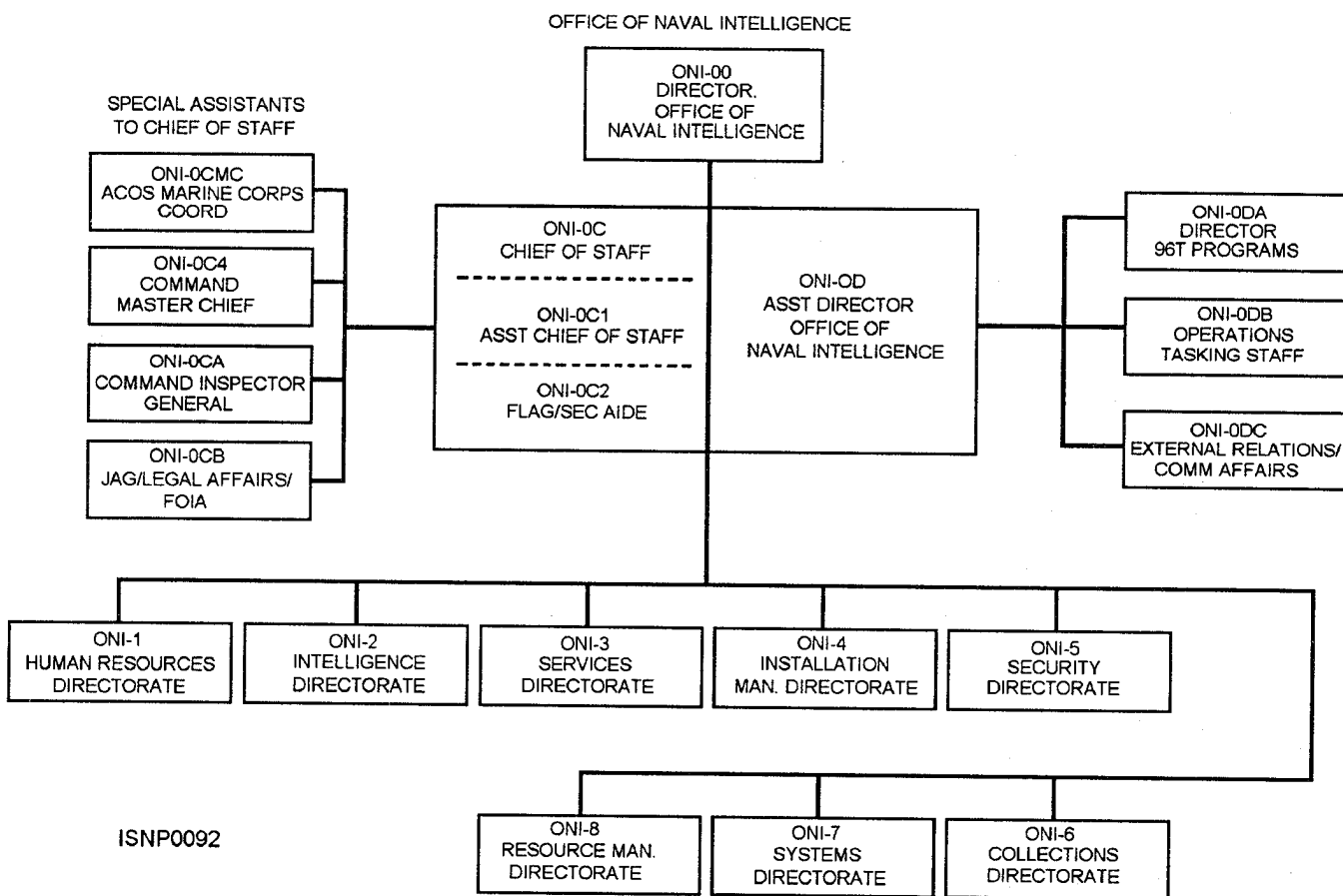

Figure AII-2.—ONI organization chart.

To accomplish the most thorough support, analysis and production are distributed among the following departments:

- **Civil Maritime Analysis Department**— provides analysis, reporting, database services, and tasking collection for current and historical intelligence relating to nonmilitary use of the sea.
- **Integration and Regional Analysis Department**— integrates intelligence from all naval warfare areas to produce comprehensive assessments of maritime-related strategies and doctrine of potential threat countries.
- **Surface and Coastal Warfare Department**— produces and coordinates the analysis of intelligence related to current and projected foreign naval surface ships and naval weapons systems. Includes the Surface Analysis Branch for Evaluation and Reporting (SABER) shop, which was established to provide near-term analysis of regional and territorial mine, coastal, and anti-landing threats in support of joint littoral warfare.
- **Strike and Air Warfare Department**— provides threat analysis on the capabilities, performance, and vulnerabilities of foreign and strike and air warfare platforms and systems, such as air-launched antiship weapons, naval and land-based anti-air defenses, and air threats to amphibious land forces. Includes the Strike Projection Evaluation and Anti-air Warfare Research (SPEAR) shop, which provides near-term threat analysis on current organization, operations, tactics, training, and readiness of military and paramilitary forces identified as potential threats to naval forces.
- **Undersea Warfare Department**— provides naval forces with all-source, in-depth analysis of foreign submarines, their characteristics, performance, tactics, and readiness. Additionally, this department provides assessments on the capabilities and vulnerabilities of foreign naval ASW assets, including air, surface, and fixed systems. Includes the Submarine Warfare Operations Research Division (SWORD), which is designed to serve the fleet with analytical

talent consisting of a unique blend of warfare specialists, intelligence officers, and expert career civilians. Support is tailored to be used at sea and by operational staffs.

ONI-6, the Collections Directorate, coordinates worldwide collection programs. Radical changes in the international security environment and the rise of regional conflicts have significantly changed the focus of the collection efforts of ONI-6. Current collection programs are heavily oriented toward non-Commonwealth of Independent States (CIS) problems, counter-proliferation of conventional and nuclear systems, counter-drug, embargo support, and illegal aliens.

ONI programs monitor the maritime shipment of goods to identify illicit cargoes of military systems, nuclear material, drugs, and illegal aliens.

Acquisition of information on foreign sensors, weapons, and platforms of all types is a major collection effort. The ONI also has a strong Foreign Materiel Program to obtain high-threat weapons to allow for the development of tactics and countermeasures to neutralize these systems. These efforts contribute to both the safety and effectiveness of deployed U. S., NATO, and UN peace-keeping forces.

The U.S. Navy manages close to 100 bilateral information exchange agreements with allied navies and intelligence services. Under these international programs, managed by ON-6, information on foreign systems, tactics, and intentions is exchanged. These agreements also serve as conduits for U.S. Navy support to allied navies.

ONI-6's Naval Attaché Affairs Office provides Navy management and coordination support for the DAS. The ONI's 16 Human Intelligence (HUMINT) sites are being integrated into the DIA's Defense HUMINT Service to provide naval expertise for their collection programs.

ONI-7, Systems Directorate, provides intelligence collection sensors, communications systems, automated data processing equipment, analytical exploitation equipment, and associated operational support to fleet and U.S. command users. ONI-7 also manages the development, acquisition, operation, and life cycle support of all ONI intelligence and communications systems.

Naval Criminal Investigative Service

The mission of the Director, Naval Criminal Investigative Service (NCIS) (figure AII-3) is to maintain, command, and operate a worldwide organization to fulfill the investigative and counter-intelligence responsibilities of the Department of the Navy. This mission also includes combat-related counterintelligence matters.

Organizationally, the NCIS consists of a headquarters located in Washington, D.C.; various field

commands, called Naval Criminal Investigative Service Field Offices (NCISFOs), each of which is under a senior civilian; and subordinate operating units, called Resident Agencies. There are about 110 NCIS units, including the various headquarters and field commands, both afloat and ashore.

Field-element locations are at every Navy and Marine Corps base, as well as those locations determined by workload requirements. Daily tasks include conducting criminal investigations for, and the provision of, counterintelligence support to the

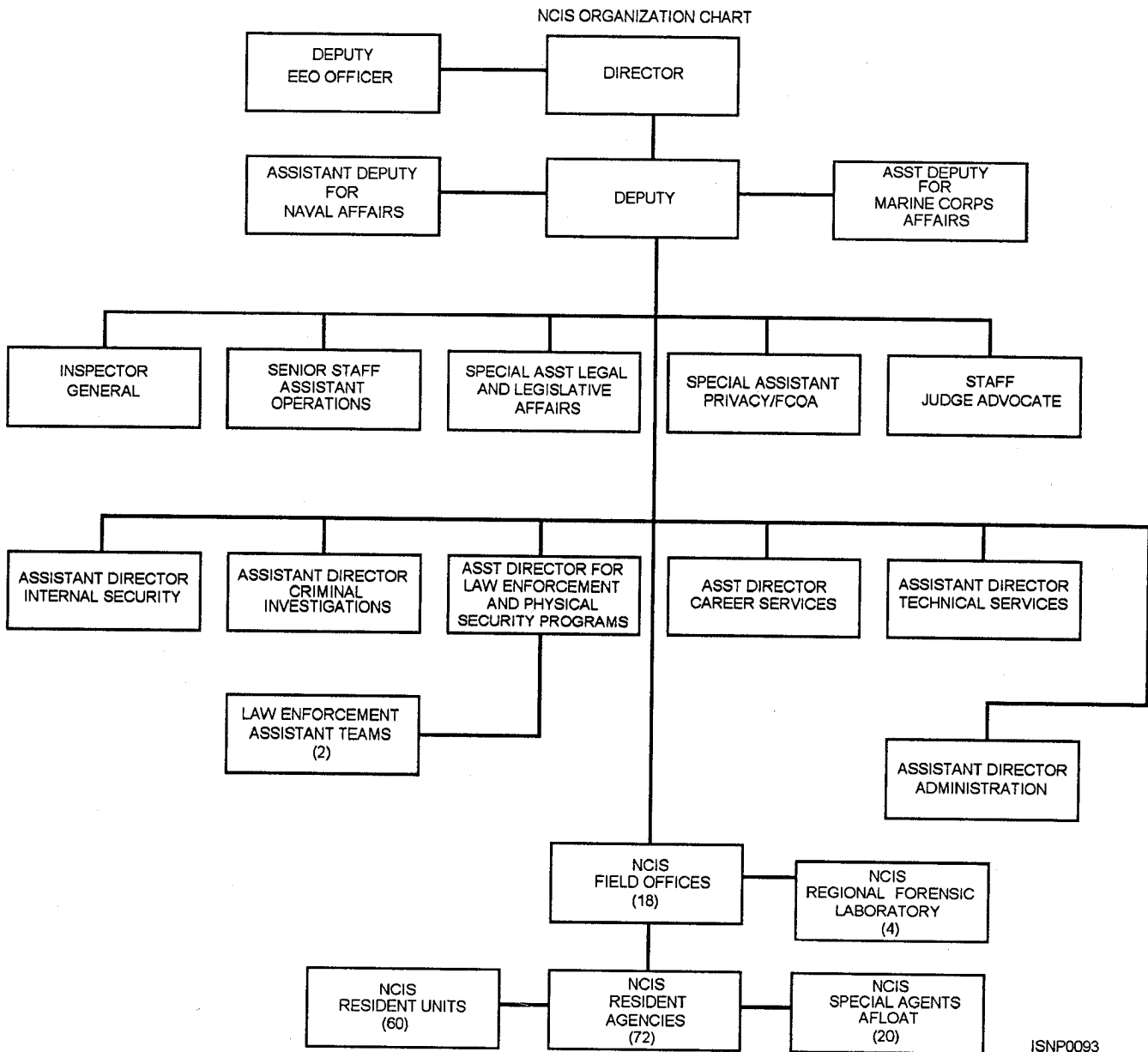

Figure AII-3.—NCIS organization chart.

Navy Department and the shore commands and operating forces. The NCIS collects, analyzes, and disseminates information of internal-security significance to Navy and Marine Corps commands.

Commander, Naval Security Group (COMNAVSECGRU)

COMNAVSECGRU is the Navy's executive agent for cryptology and information warfare and command and control warfare. It is responsible for cryptologic planning and programming, systems acquisition, training, and administration of the naval cryptologic field activities around the world.

Marine Corps participation within the Naval Security Group is provided by the Marine Support Battalion that collocates companies at selected naval cryptologic field activities. The Marine Support Battalion also provides support to naval expeditionary operations through augmentation of Fleet Marine Force Radio Battalions.

Marine Corps Intelligence Activity (MCIA)

The MCIA focuses on crisis and predeployment support to expeditionary warfare. It complements and coordinates the efforts of theater, other service, and national intelligence organizations, providing unique threat, technical, and terrain-analysis products that are tailored to Marine Corps tactical units preparing to deploy to a theater of operations. The activity serves as the service collection and production manager and as the primary coordination link with the ONI for expeditionary intelligence analysis and production. Additionally, the MCIA provides threat and technical intelligence assessments, supporting the Concept-based Requirements System in areas of service-unique doctrinal development, force structure, force modernization, training and education, and acquisition.

Coast Guard Intelligence Coordination Center (ICC)

The ICC provides strategic intelligence support to Coast Guard law enforcement, military readiness, port security, marine safety, and environmental protection missions. The ICC is the Coast Guard's primary interface with the collection, production, and dissemination elements of the national

intelligence and law enforcement communities. It serves as the Coast Guard's 24-hour I&W watch, maintaining a current picture of all maritime threats.

ARMY INTELLIGENCE

The Assistant Chief of Staff for Intelligence (ACSI), U.S. Army, has Army General Staff responsibility for all matters pertaining to the intelligence and counterintelligence activities of the U.S. Army. The ACSI has general staff responsibility for the following:

- Planning, coordinating, and effecting the fulfillment of Army intelligence and counterintelligence requirements;
- Supervising Army intelligence and counterintelligence collection, production, and dissemination activities;
- Providing communications and electronics intelligence and security;
- Establishing measures for safeguarding defense information;
- Coordinating combat intelligence;
- Maintaining liaison with foreign army personnel in the U. S.;
- Directing the Army mapping and geodesy program;
- Directing specific elements of the Army intelligence reserve; and
- Directing the Intelligence Corps, U.S. Army.

The major elements of Army intelligence are the Intelligence and Security Command (INSCOM) and the Army Intelligence Agency (AIA). The INSCOM is responsible for HUMINT, SIGINT, and counterintelligence (CI) functions; the AIA contains the headquarters staff. The AIA is presently composed of the Intelligence and Threat Analysis Center (ITAC), the Foreign Science and Technology Center, and the Missile and Space Intelligence Center. It provides intelligence users with scientific and technical as well as general military intelligence assessments.

AIR FORCE INTELLIGENCE

For intelligence matters, the Assistant Chief of Staff, Intelligence, U.S. Air Force, has Air Staff responsibilities as follows:

- Developing and implementing USAF plans and policies;
- Representing the Chief of Staff, USAF on specific joint and interagency committees of the government, that are considering intelligence matters;
- Coordinating the collection and production of air intelligence by USAF activities;
- Monitoring worldwide targeting efforts to keep the USAF apprised of current changes and developments; and
- Producing air technical intelligence from reports and analyses of foreign material.

The Air Force Intelligence Agency (AFIA) provides functional management, oversight, and headquarters review of all USAF intelligence activities. Component elements are:

- **Air Force Special Activities Center (AFSAC)**— responsible for the Air Force HUMINT program;
- **Electronics Security Command**— responsible for Air Force SIGINT and is the USAF service cryptologic unit;
- **Foreign Technology Division (FTD)**— the largest of the services' scientific and technical intelligence centers, serving both the Air Force and national level consumers; and
- **Office of Special Investigations (OSI)**— responsible for CI operations.

FEDERAL BUREAU OF INVESTIGATION (FBI)

The FBI is the chief internal security agency of the Federal Government. The Director of the FBI is responsible for investigating all violations of Federal law, except those that have been assigned by

law to some other Federal investigative agency. The FBI has jurisdiction over more than 170 different investigative matters, the most important of which include

- espionage, sabotage, treason, and other subversive activities;
- kidnapping
- extortion;
- bank robbery and larceny;
- crimes on government property or Indian reservations;
- thefts of government property;
- election law violations;
- civil rights matters; and
- assaulting or killing of a Federal officer.

Counterfeiting; postal, customs, and Internal Revenue violations; and illegal traffic in narcotic drugs are crimes handled by other Federal investigative agencies.

DEPARTMENT OF STATE INTELLIGENCE

The State Department's Bureau of Intelligence and Research (INR) carries out a program of policy-oriented research and analysis of positive foreign intelligence. This Bureau represents the State Department on the NFIB and other interdepartmental intelligence groups and committees. The head of INR is the Director, whose rank is equivalent to that of an assistant secretary.

The INR is grouped under three major sections: Current Analysis (CA), Assessments and Research (AR), and Coordination (C). Apart from the responsibilities of these sections, two additional offices serve Bureau-wide needs. They are the Office of the Executive Director (EX) and the Office of Intelligence Support (IS).

The office of Current Analysis is the largest part of the INR staff. There are seven offices. Six are geographic offices: Africa, Latin America, East Asia and Pacific, Western Europe, Near East and

South Asia, and former Communist bloc countries. The seventh office is for political-military analysis. The purpose of each office is to conduct policy-oriented research and analysis programs in its assigned area and to prepare reports and estimates for use in formulating and executing foreign policy.

The office of Assessments and Research has the primary responsibility for long-range analytical studies and is supported by five offices: Long-Range Assessments and Research, Economic Analysis, Geographer, Global Issues, and the Reports, Coordination, and Review Staff.

The office of Coordination serves as a central control point for the entire directorate. Its suboffices include Intelligence Liaison, Intelligence Coordination, and Intelligence Resources. These suboffices

- provide continuous examinations of the world situation in light of current intelligence derived from interdepartmental sources;
- support research and analysis programs with regard to economic, social, geographic, and scientific issues;
- resolve intelligence problems in relation to interregional and international policy and programs; and
- maintain liaison with other agencies concerning proposed government-sponsored social science research projects dealing with foreign affairs.

THE DEFENSE ATTACHE SYSTEM

The Defense Attaché System was created to supervise, support, and train personnel in the proper performance of their duties relating to U.S. embassy operations. When the system was established, the Secretary of Defense charged the Director, DIA with determining the organizational and command arrangements for each attaché post. The SECDEF further directed that the attaché offices be organized to maintain attaché affiliation with a particular military service, as necessary, to support the information collection mission. The organizational plan for the Defense Attaché System, as approved by the SECDEF, stressed the importance of the

intelligence collection mission of the Defense Attaché System and laid down the following concept and principles governing the organization and command relationship of the defense and service attachés:

- The Defense Attaché System is a single system with a direct chain of authority and responsibility exercised by the Director, DIA through the Defense Attaché (DATT).
- DATTs are responsible to the Director, DIA for all activities of their respective offices.
- Service attachés, for purposes of accreditation and relationships with officials of the host government, are identified by appropriate service titles and accredited as such to the host government. For internal purposes, they are under the direction and control of the DATT.
- Service attachés advise ambassadors on military and political matters. They also respond, within their organization's ability, to requests for information collection assistance from the Secretaries of their parent service departments and the Military Chiefs of their services.
- DATTs respond, within their organization's ability, to the information requirements of the Secretary of the Defense, Joint Chiefs of Staff, and commanders of unified and specified commands.

Organization

Details of the organization of Defense Attaché Offices (DAOs) vary from country to country. However, in offices that include multiple-service representation, the DATT centralizes common functions formerly accomplished in separate-service attaché offices. This centralization includes Intelligence Collection Requirements (ICR) control and assignment; collection planning correspondence, report, and reference files; and photographic services.

Functions

The Defense Attaché is charged with the following:

- Directing, controlling, operating, and administering the DAO, including the offices of the service attachés.
- Coordinating and directing all attaché collection activities within the geographic area of responsibility of the DAO. The DATT has full responsibility for the collection activities and reporting from his/her station, and normally assigns collection tasks to the service attaché who is best qualified by service experience and professional or technical training. The DATT normally reviews reports to assure that they comply with collection guidance and are responsive, sound, and as complete as possible.
- Designating the next senior attaché as acting DATT during temporary absence of the DATT.
- Perform administrative and operational duties within the DAO as directed by the DATT.
- Represent their military service Secretaries and Chiefs, keeping the DATT informed of the nature and extent of service-imposed representational requirements.
- Assume the duties of the DATT when so directed. In the event of an unforeseen incapacitation of the DATT, the next senior military attaché will assume the duties.
- Prepare efficiency, effectiveness, and fitness reports on subordinates of their respective services as required by their service regulations and appropriate DIA instructions.

The service attachés, under the direction, control, and supervision of the DATT, accomplish the following:

- Collect and report intelligence information as required by current DIA directives.

SUMMARY

This appendix has covered the basic components of the United States intelligence organization. Appendix III will cover the basic structure and components of the primary foreign intelligence agencies.

APPENDIX III

FOREIGN INTELLIGENCE AGENCIES

The United States intelligence community frequently operates in conjunction with, or in opposition to, the intelligence organizations of foreign nations. To help you understand these interactions, we will briefly discuss the intelligence agencies of the more important foreign nations.

BRITISH INTELLIGENCE SERVICE

Supervision of British intelligence falls to the Joint Intelligence Committee. This committee is concerned with overall policy control and approval of national estimates. We will mention the four primary agencies concerned with intelligence.

The two principal British intelligence sections are the *Secret Intelligence Service (MI-6)* and the *Security Service (MI-5)*.

- **MI-6**— This section, whose operations and organization are closely guarded secrets, is of special interest. It is a civilian organization and corresponds, to some extent, to our CIA. For budgetary purposes, it is carried under the Foreign Office, and appropriations usually are passed without comment as matters that are secrets of state.
- **MI-5**— Under the same budget, MI-5 is devoted to counterespionage, protection of British secrets, domestic sabotage, and security work. Other than performing certain counterintelligence actions overseas, it operates similarly to the FBI. The Security Service makes no direct arrests, but rather works mainly behind the scenes as a “Special Branch” of Scotland Yard. The Director reports to the Prime Minister through the Home Secretary.

Scotland Yard is charged with guarding the Royal family, important British officials, and visiting foreign dignitaries. It is also concerned with counterespionage and national security problems. Some functions of Scotland Yard are similar to

those performed by the United States Secret Service and the FBI.

Another important unit is the *Defense Intelligence Service*. Similar to the DIA, it combines elements of the Ministry of Defense intelligence services. An additional service is communications intelligence concerned with electronic surveillance and cryptology.

FRENCH INTELLIGENCE SYSTEM

The French intelligence organization evolved from the Service de Documentation Extérieure et de Contre-Espionnage (SDECE), or Foreign Intelligence and Counterintelligence Service. The SDECE, established in December 1945, developed from intelligence organizations that operated under General de Gaulle from 1940 to 1945.

The SDECE was in operation until 1981 when it was reorganized as the *Direction Générale de la Sécurité Extérieure (DGSE)*. Though the structure changed, the mission remained the same, namely the collection and analysis of foreign information, counterespionage outside of France, and overseas covert political activities.

Another element of the French intelligence system is the *Second Directorate of the National Defense Staff*. This organization is similar to the DIA, in that it combines elements of the formerly separate Army, Navy, and Air Force intelligence units. It is responsible for the collection and analysis of foreign military intelligence.

Internal security is the responsibility of the *Direction de la Sécurité du Territoire (DST)*. It serves in the same way as the FBI and is under the administrative control of the Ministry of the Interior.

ISRAELI INTELLIGENCE SYSTEM

The state of Israel, since its creation in 1948, has met its obvious need for intelligence and

counterintelligence with intelligence services that have gained a first-class reputation. One mark of their professionalism is that less is known about them than about other systems. The Israeli intelligence services consist of five major organizations, as follows:

- **Central Institute for Intelligence and Security**— The Central Institute, or Mossad, much like the CIA, operates primarily in foreign areas, gathering information through all the techniques used by modern intelligence systems. It carries out covert political operations that require clandestine activity. The numerous Israeli secret agents living in Arab lands, for example, are under the supervision of the Central Institute. Its director is responsible to the Prime Minister and chairs a committee that presides over the entire Israeli intelligence system.
- **Shin Bet**— This agency, perhaps Israel's best-known security unit, is named after the Hebrew initials for General Security Services. Its main function is counterintelligence. Shin Bet is also an investigative agency concerned with potential sabotage, Arab terrorist activities, and security matters having a strong political flavor.
- **Intelligence Corps of the Defense Forces**— This agency, as its name implies, provides intelligence to the Israeli armed forces. Its chief is the military intelligence adviser to the Defense Minister.
- **Research Department of the Foreign Ministry**— Resembling the Bureau of Intelligence and Research in the U.S. State Department, this relatively small unit focuses on political information, including policy-oriented studies and the evaluation of information supplied through diplomatic channels.
- **Special Investigations Department of the Israel Police Force**— This agency is concerned with investigations inside Israel's boundaries.

The successes of Israel in its wars with Arab countries maybe attributed, in large measure, to the efficiency of its intelligence system. The secret

services of Israel, for the most part, have operated without exposure and with apparent success. Israeli law prohibits domestic publication of information about the intelligence agencies.

FORMER SOVIET INTELLIGENCE SERVICES

Following the breakup of the former Soviet Union, the Committee for State Security (KGB) and Main Intelligence Directorate of the General Staff (GRU) also broke up into 15 separate organizations, by individual state. In general, the new organizations simply translated their name into their native language and continued business as usual. Since their structures strongly resemble either the original KGB structure or the current Russian structure, only the Russian services will be addressed individually. The organizations discussed next currently conduct intelligence for the Russian Federation.

FOREIGN INTELLIGENCE SERVICE OF THE RUSSIAN FEDERATION (SVR)

Formerly the First Chief Directorate of the KGB, the SVR was established in 1991. This service provides intelligence data necessary for making fundamental decisions concerning foreign and economic policy and the support of scientific and technical progress.

FEDERAL AGENCY FOR GOVERNMENT COMMUNICATIONS AND INFORMATION (FAPSI)

Among other things, FAPSI, under authorization of Russian law, plans and conducts foreign intelligence gathering in the sphere of encoded, secret, and other special communications using radio-electronic (SIGINT) facilities.

FEDERAL SECURITY SERVICE (FSB)

Until recently, the FSB was known as the Federal Counterintelligence Service (before that, as the Second Chief Directorate of the KGB). Its mission continues to be as follows:

- To conduct operations to reveal, forestall, and suppress the subversive intelligence

activity of foreign special services and organizations against the Russian Federation;

- To obtain and provide to the president intelligence information on threats to the security of the Russian Federation,
- To fight terrorism, the illegal turnover of weapons and narcotics, illegal armed formations, or prohibited associations encroaching upon the constitutional system;
- To ensure the safekeeping of state secrets; and
- To provide counterintelligence support to protect the state border.

MAIN INTELLIGENCE DIRECTORATE OF THE RUSSIAN GENERAL STAFF (GRU)

The GRU is part of the Russian military. It is exclusively responsible for military intelligence, and is involved in radio intercept, radio technology, and aerial and space reconnaissance. It has special units that monitor worldwide communications activity. Military Districts and below (operational and tactical level) maintain the appropriate reconnaissance services, and GRU Spetsnaz units are responsible for conducting reconnaissance combat operations.

The intelligence services of the other CIS (Commonwealth of Independent States) states have followed similar developments since the breakup of the former Soviet Union, albeit on a less grandiose scale. The FSB claims to have reached accords with the counterintelligence services of the Commonwealth states, solidifying cooperation between them.

The CIS military intelligence organizations have begun to work together again as well. The CIS Air Defense Agreement, concluded in the spring of 1995, included provisions for sharing information on airspace situations, radar recognition, and information from ballistic missile early-warning centers and a SIGINT site in the Ukraine.

CHINESE INTELLIGENCE SYSTEM

Mainland China's intelligence system closely resembles that of the former Soviet Union, although not much is known about it. Less distinct lines exist in China between the professional intelligence function and Communist Party administrative functions. The best information suggests that the intelligence organization consists of four major units:

- Those of the party;
- The State Council (the government bureaucracy);
- The military establishment (Defense Ministry); and
- The Ministry of Foreign Affairs.

Under the title "Social Affairs Department," the intelligence unit of the Central Committee of the Communist Party attempted for some years to exert dominant control over the entire intelligence system, much in the fashion of the old Soviet KGB. This department was thought to have been abolished during the Cultural Revolution of the late 1960s. It is probable that only its name was changed. Like the old USSR, the army, through the Defense Ministry's large intelligence staff, is potentially a strong competitor of the civilian intelligence agencies,

The army chief of staff in China also runs the *Military Secret Police* and heads the "*Political Department*" of the Defense Ministry. Clearly, there are two main functions within the military: first, to assure the reliability and loyalty of the Chinese military establishment, in effect, an internal security function; and second, to secure positive intelligence about foreign military systems. The State Council operates a *Ministry of Public Security* that concerns itself mainly with internal security.

Finally, there is the *Foreign Intelligence Department* in the Ministry of Foreign Affairs. It is responsible for intelligence gathering and other overseas activities, including covert political action. Its agents operate, like those of most other nations, through embassies, legations, the New China News Agency, overseas Chinese, and other channels.

APPENDIX IV

THE METRIC SYSTEM

The metric system was developed by French scientists in 1790 as an easy-to-use system of weights and measures to benefit science, industry, and commerce. The metric system is based entirely on powers of 10, eliminating the need to use various mathematical bases, such as 12 inches to a foot, 3 feet to a yard, and 5,280 feet to a mile common to the English system. In the metric system, one unit of measure can be changed to a larger or smaller unit of measure by simply moving a decimal point.

The metric system of linear measurement is based on the "meter," which is one ten-millionth of the distance from the Equator to the North Pole. The metric system of weights is based on the gram, which is the weight of a specific quantity of pure water.

Soon after the system was developed, scientists throughout the world adopted it and were able to deal with the mathematics of their experiments more easily. Furthermore, other scientists anywhere in the world could understand the data and particulars of their work. During the early 19th century, many European nations adopted the new system for engineering and commerce. Metrics enabled these countries to trade manufactured goods without having to buy special tools for making repairs. They could also buy and sell machine tools and other sophisticated and precision machinery without troublesome modifications or alterations.

With the exception of the United States, all the industrialized nations of the world have adopted the metric system. Even England and Canada are changing from their traditional systems of measure. Although the metric system has not been officially legislated by the Congress, the use of the metric system is becoming more prominent in this country. Most automobile mechanics own metric wrenches to work on foreign cars or metric components in American cars. Almost all photographic equipment is built to metric standards. Chemicals and drugs are usually sold in metric quantities, and "calorie counters" are using a metric unit of thermal energy.

Because we are allied with countries who use the metric system, much of our military information is presented in metric terms. Military maps use meters and kilometers instead of miles, and many weapons are in metric sizes, such as 7.62 mm, 20 mm, 40 mm, 75 mm, and 155 mm. Interchange of military equipment has caused a mixture of metric and English measure equipment since World War I when the Army adopted the French 75-mm field gun, and World War II when the Navy procured the Swedish 40-mm Bofors and the Swiss 20-mm Oerlikon heavy machine guns.

It is inevitable that the United States will officially adopt the metric system. Exactly when this will happen and how rapidly the changeover will occur will depend on economics, since the expense of retooling our industry and commerce to new measurements will be very great. The cost of conversion will be offset by increased earnings from selling machinery and products overseas. Another benefit is that ideas will be able to go directly from the drawing board to the assembly line. Today, scientists use the metric system, but their calculations have to be translated into English measure to be used by industry.

Although you will find it easier to solve problems using the metric system, at first you will find it difficult to visualize or to estimate quantities in unfamiliar units of measure. Fortunately, many metric units can be related to equivalent units in the English system.

The meter, which is the basic unit, is about one-tenth longer than a yard.

The basic unit of volume, the liter, is about one quart. The gram is the weight of a cubic centimeter, or milliliter, of pure water and is the basic unit of weight. As a common weight though, the kilogram, or kilo, which equals the weight of a liter of water, weighs 2.2 pounds. The square centimeter is used where we would use the square inch, and where we measure by the fluid ounce, the metric system uses the milliliter (ml). For power measure, the metric

system uses the kilowatt (kW), which is about 1.3 horsepower.

In terms of distance, a land mile is eight-fifths of a kilometer, and a nautical mile is 1.852 kilometers, or nearly 2 kilometers,

A basic metric expression of pressure is the kilogram per square centimeter, which is 14.2 psi, nearly 1 atmosphere of pressure.

When working on foreign machinery, you may notice that your half-inch, three-quarter inch, and one-inch wrenches will fit many of the bolts. These sizes correspond to 13 mm, 19 mm, and 26 mm, respectively, in the metric system and are very popular because they are interchangeable. The 13/16-inch spark plug wrench, which is standard in this country, is intended to fit a 20-mm nut.

The basic quantities of the metric system are multiplied or divided by powers of 10 to give other workable values. We cannot easily measure machine parts in terms of a meter, so the millimeter, or one-thousandth of a meter is used. For very fine measure, the micron—also called the micrometer—can be used. It is one-millionth of a meter, or one-thousandth of a millimeter. For small weights, the milligram, one-thousandth of a gram, is used. All of these multiples are expressed with standard prefixes taken from Latin:

micro	= 1/1,000,000
milli	= 1/1,000
centi	= 1/100
*deci	= 1/10
*deca	= 10
*hecto	= 100
kilo	= 1,000
*myria	= 10,000
mega	= 1,000,000

*Rarely used

Over the next few years, the metric system will become more used by the Navy as well as by the civilian world. You will find the system easy to work with once you have mastered its basic terms. It will be inconvenient to translate values from our present system to the metric system, but this operation will become unnecessary once the new measurements are totally adopted.

Tables of equivalent English measure and metric equivalents are essential when you work simultaneously with both systems. The table which follows shows the equivalent measures of the two systems. The columns on the left have the equivalent values, which are accurate enough for most work, and on the right are the multiples used to convert the values with a high degree of accuracy.

CONVERSION TABLES

Multiply	By	To Obtain	Multiply	By	To Obtain
Acres	40.47	Ares	Feet	30.48	Centimeters
Acres	4,047.	Centares	Feet	0.1667	Fathoms
Acres	10	Square chains	Feet	0.3048	Meters
Acres	43,560	Square Feet	Feet per Minute	0.011136	Miles per Hour
Acres	4,840	Square Yards	Feet per Second	0.5921	Knots
Ares	0.02471	Acres	Feet per Second	18.288	Meters per Minute
Ares	100	Centares	Feet per Second	0.6818	Miles per Hour
Ares	1,076	Square Feet	Furlongs	10	Chains
Ares	119.6	Square Yards	Furlongs	660	Feet
Barrels (U.S., dry)	3.281	Bushels	Furlongs	40	Rods
Barrels (U.S., liquid)	4.21	Cubic Feet	Furlongs	220	Yards
Barrels (U.S., liquid)	31.5	Gallons	Gallons (British)	4,546.1	Cubic Centimeters
Board Feet (1' x 1' x 1')	144	Cubic inches	Gallons (British)	0.1605	Cubic Feet
Cable lengths (U.S.)	120	Fathoms	Gallons (British)	277.274	Cubic Inches
Cable lengths (U.S.)	720	Feet	Gallons (British)	1.2009	Gallons (U.S.)
Cable lengths (U.S.)	240	Yards	Gallons (British)	4.546	Liters
Centares	10.76	Square feet	Gallons (British)	4	Quarts (British)
Centares	1.196	Square Yards	Gallons (U.S.)	0.03175	Barrels (liquid, U.S.)
Centimeters	0.3937	Inches			
Cubic Centimeters	0.06102	Cubic Inches	Gallons (U.S.)	3,785.4	Cubic Centimeters
Chains	66	Feet	Gallons (U.S.)	0.13368	Cubic Feet
Chains	100	Links	Gallons (U.S.)	231	Cubic Inches
Chains	4	Robs	Gallons (U.S.)	0.8327	Gallons (British)
Cubic Feet	1,728	Cubic Inches	Gallons (U.S.)	3.785	Liters
Cubic Feet	0.02832	Cubic Meters	Gallons (U.S.)	4	Quarts (U.S.)
Cubic Feet	0.03704	Cubic Yards	Grams	15.43	Grains
Cubic Feet	6.229	Gallons (British)	Grams	0.001	Kilograms
Cubic Feet	7.481	Gallons (U.S.)	Grams	1,000	Milligrams
Cubic Feet	28.316	Liters	Grams	0.03527	Ounces (avoir-dupois)
Cubic Inches	16.39	Cubic Centimeters			
Cubic Inches	0.0005787	Cubic Feet	Hands	10.16	Centimeters
Cubic Inches	0.003606	Gallons (British)	Hands	4	Inches
Cubic Inches	0.004329	Gallons (U.S.)	Hectares	2.471	Acres
Cubic Inches	0.01639	Liters	Hectares	100	Ares
Cubic Meters	35.31	Cubic Feet	Hectoliters	0.1	Cubic Meters
Cubic Meters	1.308	Cubic Yards	Hectoliters	26.417	Gallons (U.S.)
Cubic Yards	27	Cubic Feet	Hectoliters	100	Liters
Cubic Yards	0.7646	Cubic Meters	Hogsheads	2	Barrels (Liquid, U.S.)
Cubic Yards	764.6	Liters			
Degrees (C.)+ 17.8	1.8	Degrees (F.)	Hogsheads (U.S.)	63	Gallons (U.S.)
Degrees (F.) -32	0.5556	Degrees (C.)	Hundredweights	0.508	Quintals (metric)
Degrees	0.01745	Radians	Inches	72	Points
Fathoms	0.00833	Cable Lengths (U.S.)	Inches	6	Picas
			Inches	6	Ems
Fathoms	6	Feet	Inches	12	Ens
Fathoms	1.8288	Meters	Inches	2.54	Centimeters

Multiply	By	To Obtain	Multiply	By	To Obtain
Inches	0.0833	Feet	Miles, Nautical	6,076.1	Feet
Inches	1,000	Mils	Miles, Nautical	72,963	Inches
Inches	0.0277	Yards	Miles, Nautical	1.8532	Kilometers
Inches of Mercury	0.49131	Pounds per Square Inch	Miles, Nautical	1,853.2	Meters
Kilograms	1,000	Grams	Miles, Nautical	1.1508	Miles, Statute
Kilograms	2.2046	Pounds (Avoirdupois)	Miles, Nautical	1	Minutes of Latitude
Kiloliters	1	Cubic Meters	Miles, Nautical	2,026.8	Yards
Kiloliters	1.308	Cubic Yards	Miles per Hour (Statute)	88	Feet per Minute
Kiloliters	264.18	Gallons (U.S.)	Miles per Hour (Statute)	1.467	Feet per Second
Kiloliters	1,000	Liters	Miles, per Hour	0.8684	Knots
Kilometers	4.557	Cable Lengths	Miles, Statute	7.33	Cable Lengths
Kilometers	3,280.8	Feet	Miles, Statute	5,280	Feet
Kilometers	39,370	Inches	Miles, Statute	8	Furlongs
Kilometers	1,000	Meters	Miles, Statute	63,360	Inches
Kilometers	0.5396	Miles, Nautical	Miles, Statute	1.6093	Kilometers
Kilometers	0.62137	Miles, Statute	Miles, Statute	1,609.3	Meters
Kilometers	1,093.6	Yards	Miles, Statute	0.8689	Miles, Nautical
Knots	1.1516	Statute Miles per Hour	Miles, Statute	1,760	Yard
Knots	1.688	Feet per Second	Millier (See Tons - Metric)		
Leagues, Nautical	25.33	Cable Lengths	Milliradians	206.265	Seconds of Arc
Leagues, Nautical	5.5597	Kilometers	Mils	0.001	Inches
Leagues, Nautical	3	Miles, Nautical	Myriameters	10	Kilometers
Leagues, Statute	4.8280	Kilometers	Ounces (avoirdupois)	28.3495	Grams
Leagues, Statute	3	Mile, Statute	Pint (Liquid, U.S.)	4	Gills (U.S.)
Links	7.92	Inches	Pint (Liquid, Br.)	4	Gills (British)
Liters	1,000	Cubic Centimeters	Pint (Liquid, Br.)	0.56825	Liters
Liters	61.05	Cubic Inches	Pint (Liquid, U.S.)	0.4732	Liters
Liters	0.21998	Gallons (British)	Pounds (avoirdupois)	7,000	Grains
Liters	0.26418	Gallons (U.S.)	Pounds (avoirdupois)	453.59	Grams
Liters	0.8799	Quarts (British)	Pounds (avoirdupois)	0.4536	Kilograms
Liters	0.908	Quarts (U.S., dry)	Pounds (avoirdupois)	16	Ounces
Liters	1.0567	Quarts (Liquid, U.S.)	Pounds (avoirdupois)	1.2153	Pounds (troy)
Meters	100	Centimeters	Pounds (troy)	0.8229	Pounds (avoirdupois)
Meters	0.001	Kilometers	Pounds per Square Inches	2.03537	Inches of Mercury
Meters	1.0936	Yards	Quart (British)	1.1365	Liters
Meters	3.281	Feet	Quart (British)	2	Pints (British)
Meters	39.37	Inches	Quart (Liquid, U.S.)	0.9463	Liters
Meters	1,000	Millimeters	Quart (U.S.)	2	Pints (U.S.)
Meters	1.0936	Yards	Quintals (Metric)	1.97	Hundredweights
Meters per Minute	0.0547	Feet per Second	Quintals (Metric)	100	Kilograms
Meters per Second	2.237	Miles per Hour			
Microns	0.001	Millimeters			
Miles, Nautical	8.44	Cable Lengths			











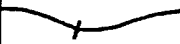



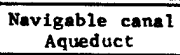

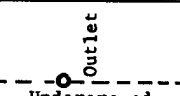

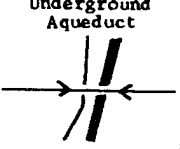

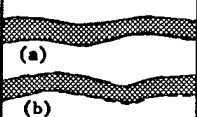

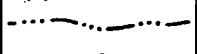

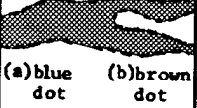

Multiply	By	To Obtain	Multiply	By	To Obtain
Radians	57.30	Degrees	Square Miles, Statute	259	Hectares
Rods	16.3	Feet	Square Miles, Statute	2.59	Square Kilometers
Rods	25	Links	Square Yards	0.8362	Centares
Square Centimeters	0.1550	Square Inches	Square Yards	9	Square Feet
Square Feet	0.09209	Centares	Square Yards	1,296	Square Inches
Square Feet	929	Square Centimeters	Tons (Long)	1.016	Metric Tons
Square Feet	144	Square Inches	Tons (Long)	2,240	Pounds (Avoirdupois)
Square Feet	0.1111	Square Yards			
Square Inches	6.452	Square Centimeters	Tons (Metric)	1,000	Kilograms
Square Inches	0.006944	Square Feet	(Millier)		
Square Kilometers	100	Hectares	Tons (Metric)	2,204.6	Pounds (Avoirdupois)
Square Kilometers	0.3861	Square Miles	(Millier)		
		(Statute)	Tons (Short)	0.9072	Metric Tons
Square Meters (See Centares)			Tons (Short)	2,000	Pounds (Avoirdupois)
Square Miles, Statute	640	Acres	Yards	91.44	Centimeters
Square Miles, Statute	25,900	Ares	Yards	0.9144	Meters

APPENDIX V
MAP SYMBOLS

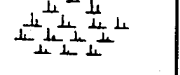
PART 1. TOPOGRAPHIC SYMBOLS

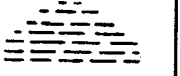
DRAINAGE FEATURES

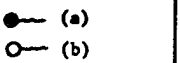
NOTE: Drainage features are normally printed in blue on all charts using color differentiation.

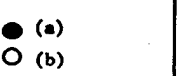
<p>SHORE LINE. (Mean high water line). (a) Definite. (b) Indefinite or unsurveyed.</p>		<p>SMALL FALLS.</p>	
<p>PERENNIAL LAKE OR POND. (a) Definite shore line. (b) Indefinite or unsurveyed shore line.</p>		<p>NAVIGABLE CANAL, IN OPERATION. (a) Narrow. (b) Wide.</p>	
<p>INTERMITTENT LAKE OR POND.</p>		<p>AQUEDUCT.</p>	
<p>DRY OR CYCLICAL LAKE OR POND.</p>		<p>UNDERGROUND AQUEDUCT, WITH OUTLET.</p>	
<p>RESERVOIR WITH NATURAL SHORE LINE.</p>		<p>ELEVATED CONDUIT OF ANY TYPE.</p>	
<p>NARROW PERENNIAL STREAM. (a) Surveyed. (b) Unsurveyed.</p>		<p>SALT EVAPORATOR.</p>	
<p>WIDE PERENNIAL STREAM. (a) Surveyed. (b) Unsurveyed.</p>		<p>MARSH OR SWAMP.</p>	
<p>INTERMITTENT STREAM.</p>		<p>COASTAL MARSH IN TIDAL WATERS.</p>	
<p>NARROW WASH OR DRY STREAM. (a) United States or foreign. (b) Foreign (in certain arid areas).</p>		<p>COASTAL MARSH IN NONTIDAL WATERS.</p>	
<p>WIDE WASH OR DRY RIVER BED. (a) United States or foreign. (b) Foreign (in certain arid areas).</p>		<p>HUMMOCKS AND RIDGES IN SWAMPS OR MARSHES.</p>	
<p>BRAIDED STREAM.</p>		<p>FISH PONDS.</p>	
<p>DISAPPEARING STREAM.</p>		<p>RICE PADDY.</p>	
<p>LARGE RAPIDS.</p>		<p>LAND SUBJECT TO INUNDATION.</p>	
<p>LARGE FALLS.</p>		<p>SPRING. (a) Perennial. (b) Intermittent.</p>	
<p>SMALL RAPIDS.</p>		<p>WELL. (a) Perennial. (b) Intermittent.</p>	

ISNP0094

RELIEF FEATURES

CONTOURS.
 (a) Index. (b) Intermediate.
 (c) Supplementary.

APPROXIMATE CONTOURS.
 (a) Index. (b) Intermediate.
 (c) Supplementary.

FORM LINES.

HACHURES.

HIGH CLIFF.
 (Height Equal to or Greater Than
 Contour Interval.)

ABRUPT SLOPE OR SCARP.
 (Height Less Than the Contour
 Interval.)

DEPRESSION.
 (Depth Less Than Contour Interval.)

DEPRESSION.
 (Depth Greater Than Contour
 Interval.)

CREVICE.
 (a) Large. (b) Small.

CUT.

FILL.

SAND.

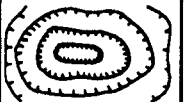

SAND BEACH.

GRAVEL BEACH.

BOULDER-STREWN BEACH.

STRIP MINE, TAILINGS PILE, MINE DUMP.

ASPHALT LAKE.

MOUNTAIN PASS.

ICEFIELD OR SNOWFIELD.

GLACIER.

GLACIAL MORaine.

HIGH ICE CLIFF.
 (Height Equal to or Greater Than
 Contour Interval.)

LOW ICE CLIFF.
 (Height Less Than Contour Interval.)

CAVE.
 (a) Land cave. (b) Ice cave.







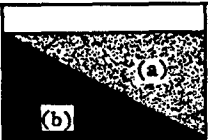
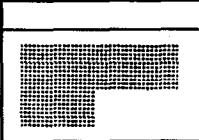

NOTE: Ice and snow features are normally printed in blue on all charts using color differentiation.

ISNP0095

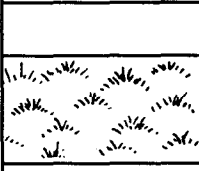
VEGETATION FEATURES

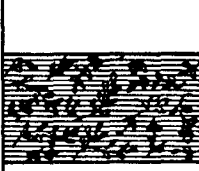
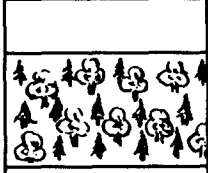
NOTE: Vegetation features are normally printed in green on all charts using color differentiation

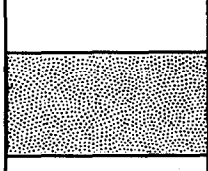
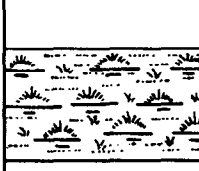
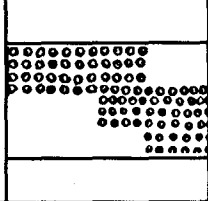
<p>WOOD OR BRUSHWOOD (when no distinction is made). (a) and (b) are alternate symbol</p>		<p>VINEYARD</p>	
<p>CONIFEROUS WOODS (when a distinction is made).</p>		<p>TROPICAL GRASS</p>	
<p>DECIDUOUS WOODS (when a distinction is made).</p>		<p>MANGROVE Vegetation: Green Line: Blue</p>	
<p>MIXED WOODS (when a distinction is made).</p>		<p>NIPA Vegetation: Green Line: Blue</p>	
<p>SCRUB</p>		<p>MARSHY AREAS IN NORTHERN LATITUDES</p>	
<p>ORCHARD OR PLANTATION</p>			

ISNP0096

HYDROGRAPHIC FEATURES

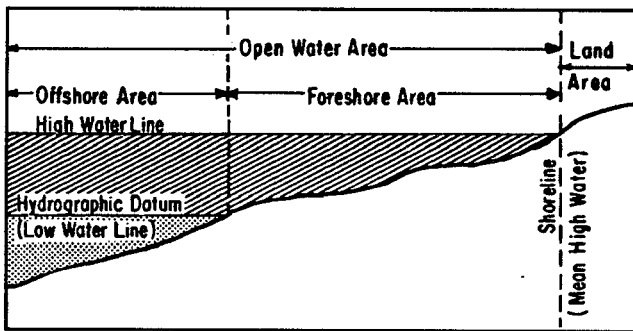

DEFINITION OF COASTAL TERMS

FORESHORE FLAT

REEF OR LEDGE
(a) Large. (b) Small.

SUNKEN ROCK
(a) Potential danger to navigation.
(b) Actual danger to navigation.

ROCK, BARE, OR AWASH
(a) Potential danger to navigation.
(b) Actual danger to navigation.

EXPOSED WRECK

SUNKEN WRECK
(a) Potential danger to navigation.
(b) Actual danger to navigation.

SUNKEN DANGER OR OBSTRUCTION
(a) Least depth indicated.
(b) Depth determined by wire drag.

LIMIT OF DANGER LINE

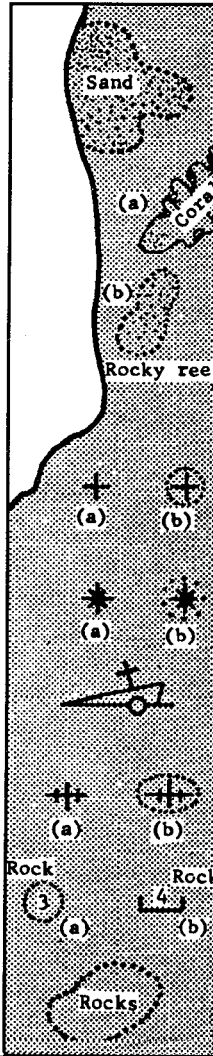

SOUNDING

NO-BOTTOM SOUNDING

SWEPT DEPTH

DEPTH CURVES

BOTTOM CHARACTERISTICS

BREAKER
(a) Limits known.
(b) Limits unknown.

CURRENT
(a) General. (b) Flood. (c) Ebb.

AREA LIMITS







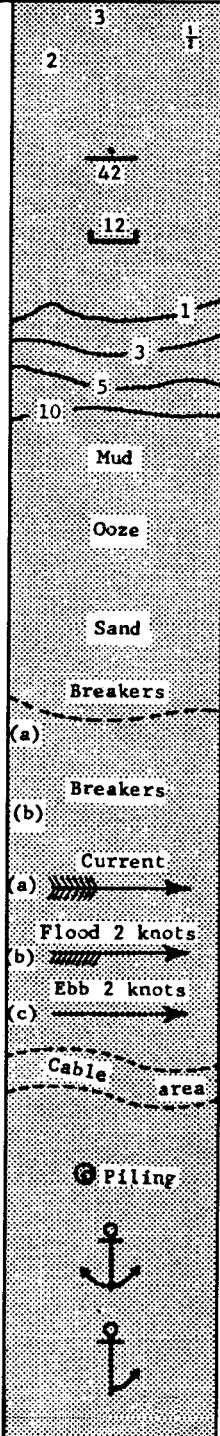









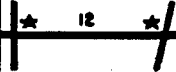

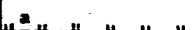

DOLPHIN, PILING, STUMP, SNAG

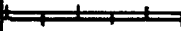
ANCHORAGE FOR LARGE VESSELS
(Shown only on maps of foreign areas.)

ANCHORAGE FOR SMALL VESSELS
(Shown only on maps of foreign areas.)

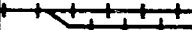

ISNP0097

ROADS			
DUAL HIGHWAY.	8 LANES DUAL	POINT OF CHANGE IN NUMBER OF LANES OF EXTRA-WIDTH ROAD.	DUAL 6 LANES 4 LANES
MAIN ROAD.		ROUTE MARKER. (a) Federal or national. (b) State, province or equivalent.	a  b 
SECONDARY ROAD.		STREETS IN DEVELOPED AREAS.	
HARD-SURFACE, ALL-WEATHER ROAD, LESS THAN TWO LANES WIDE.		STREET ENDING AT BARRIER OR EMBANKMENT.	
LOOSE-SURFACE, GRADED, ALL-WEATHER ROAD.		TRAFFIC CIRCLE.	
LOOSE-SURFACE, DRY-WEATHER, OR DIRT-ROAD.	-----	CLOVERLEAF.	
TRACK.	-----	STEEP GRADIENTS ON ROADS.	
TRAIL.	-----	ROAD DISTANCES.	
ROAD UNDER CONSTRUCTION.	CONSTRUCTION -----		
RAILROADS			
SINGLE-TRACK RAILROAD, IN OPERATION (a) Normal or broad gage. (b) Narrow gage.	a  b 	RAILROAD YARD.	
DOUBLE- OR MULTIPLE-TRACK RAILROAD, IN OPERATION. (a) Normal or broad gage. (b) Narrow gage.	a  b 	RAILROADS IN JUXTAPOSITION.	
DOUBLE- OR MULTIPLE-TRACK RAILROAD, NONOPERATING. (a) Normal or broad gage. (b) Narrow gage.	a CONSTRUCTION  b CONSTRUCTION 	TURNTABLE.	
POINT OF CHANGE IN THE GAGE OR THE NUMBER OF TRACKS.	3 TRACKS 4 TRACKS 	RAILROAD STATION.	
RAILROAD IN STREET OR WHARF.		CAR LINE.	
RAILROAD SIDING.		AERIAL CABLEWAY, SKI LIFT, OR CONVEYOR BELT.	SKI LIFT -----

ISNP0098









COMMUNICATIONS FEATURES		POPULATED PLACES AND BUILDINGS	
OVERPASS OR UNDERPASS (a) Two-level crossing. (b) Three-level crossing.		BUILT-UP AREA	
GRADE CROSSING		NATIVE SETTLEMENT	
ROAD TUNNEL		BUILDINGS IN GENERAL	
RAILROAD TUNNEL		SCHOOL	
RAILROAD BRIDGE OR VIADUCT		CHURCH	
RAILROAD DRAWBRIDGE		WATERMILL	
HIGHWAY BRIDGE OR VIADUCT		WINDMILL OR WINDPUMP	
HIGHWAY DRAWBRIDGE		CEMETERY	
FOOTBRIDGE		LIGHTHOUSE OR LIGHT	
FERRY		FORT	
FORD		POPULATED PLACE, LIMITS KNOWN	
		POPULATED PLACE, LIMITS UNKNOWN	
		TOWN, VILLAGE OR SETTLEMENT	
		RUINS (a) Large. (b) Small.	

ISNP0099

PUBLIC WORKS AND INDUSTRIAL

SMALL DAM		DRYDOCK	Drydock
DAM CARRYING ROAD		MARINE RAILROAD	
LARGE MASONRY DAM		TANKS	Oil
PASSABLE LOCK		WELL	Oil
SMALL CANAL LOCK		SEWAGE DISPOSAL OR FILTRATION BED	Sewage disposal bed
SLUICE GATE		PIPELINE	Pipeline
SMALL BREAKWATER, JETTY OR DIVERSION DAM		UNDERGROUND PIPELINE	Underground pipeline
LARGE BREAKWATER		LANDMARK OR LOCATED OBJECT	Tower
SUBMERGED BREAKWATER		OPEN-PIT MINE OR QUARRY	
LARGE SEAWALL		MINE SHAFT	(a)
SMALL PIER, DOCK OR WHARF		(a) United States (b) Foreign	(b)
LARGE PIER, DOCK OR WHARF		MINE TUNNEL	(a)
FERRY SLIP		(a) United States (b) Foreign	(b)
RAMP		TELEPHONE AND TELEGRAPH LINES	Tel
		POWER-TRANSMISSION LINES	
		PROMINENT FENCE	
		RACE TRACK	
		AIRPORT OR AIRFIELD	
		LANDING GROUND	
		SEAPLANE BASE	
	SEAPLANE ANCHORAGE		

ISNP0100

CONTROL POINTS AND ELEVATIONS			
HORIZONTAL CONTROL POINT.		MONUMENTED BENCH MARK AT HORIZONTAL CONTROL POINT.	
MONUMENTED BENCH MARK.	792	ASTRONOMIC POSITION.	
BOUNDARIES			
INTERNATIONAL.		SECOND CLASS ADMINISTRATIVE.	
MAJOR ADMINISTRATIVE.		SPECIAL.	
FIRST CLASS ADMINISTRATIVE.		INTERNATIONAL BOUNDARY MARKER.	

ISNP0101

PART 2. AERONAUTICAL CHART SYMBOLS

RADIO FACILITIES

Examples of voice and CW calls are shown below

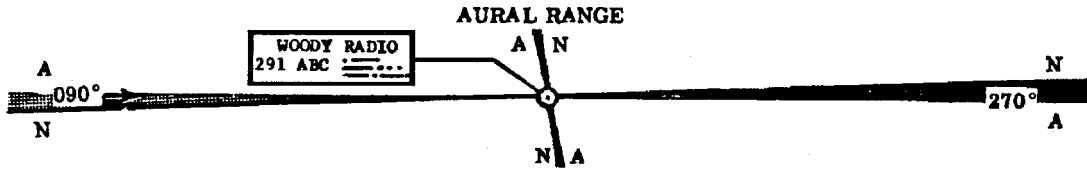
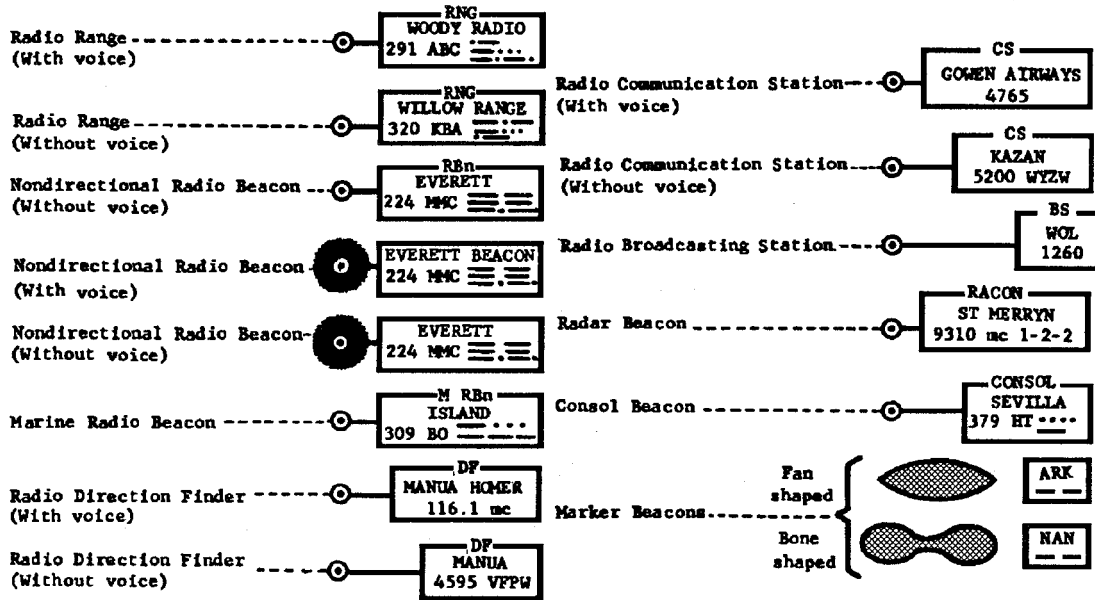

The heavy line indicates the "N" quadrant. The bearings shown are magnetic.

VHF OMNIRANGE (VOR)

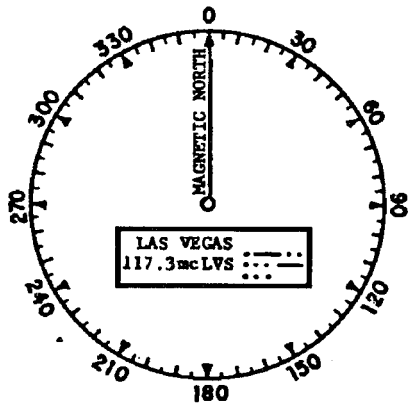

Bearings are magnetic from the station

VHF FOUR-COURSE VISUAL-AURAL RANGE (VAR)

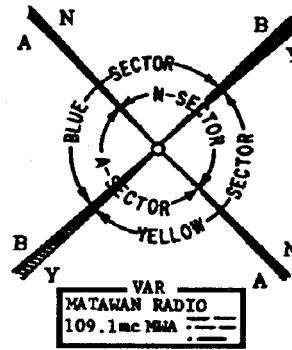

AIR TRAFFIC CONTROL

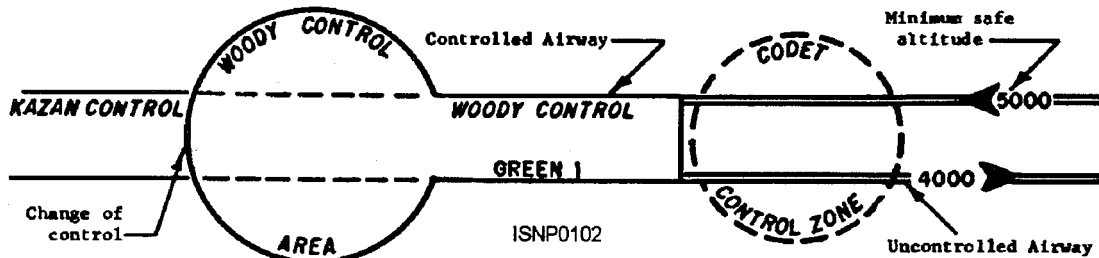

AERODROMES

AERODROMES WITH FACILITIES

SEAPLANE LANDPLANE

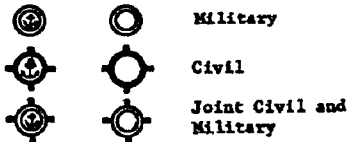

AERODROMES WITH EMERGENCY OR NO FACILITIES

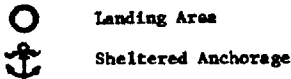

LANDPLANE

HARMON FIELD
18 *LN* 46
 Airport of Entry
 ILS GCA
 278 126.18 mc

18 Elevation in feet
L Minimum lighting (Beacon boundary or runway and obstruction lights.)
H Hard surface runway

SEAPLANE

NAS ANACOSTIA
00 *IS* 62
 2870

46 Length of longest runway to nearest hundred feet
S Normally sheltered take-off area

The Facility Code Character is replaced by a dash if specific information is not available or if the facility itself is not available.

GCA-Ground Control Approach system
 ILS-Instrument Landing System

278 126.18 mc indicates control tower transmitter freqs

(Tower call is shown if not identical with aerodrome name)

WHEN AERODROME PATTERNS ARE USED THE FOLLOWING SYMBOLS APPLY

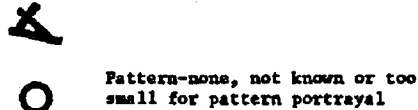
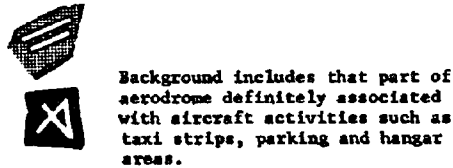

M/RHEIN-MAIN/60
369

M Military Aerodrome
C Civil Aerodrome
MC Joint Military and Civil Aerodrome
60 Runway length to nearest hundred feet
369 Aerodrome elevation



Aerodromes that are abandoned or not usable are so labeled.

MISCELLANEOUS

Rotating or Oscillating Light.....★	Flashing Light (With code).....★	F1
Rotating Light (With flashing code lights).....★	Lightship.....★	
Rotating Light (With course lights).....★	Marine Light.....Occ W R G ●	
Flashing Light.....★		
F-Fixed QkF1-Quick Flashing Occ - Occulting	Gp - Group G - Green (U) - Unwatched	
F1-Flashing IQkF1-Interrupted Quick Flashing Alt - Alternating	R - Red B - Blue SEC - Sector	
	W - White sec - Second	

Marine lights are white unless colors are indicated;
 alternating lights are red and white unless otherwise indicated.

Obstruction..... ¹¹⁰⁸ (Numerals in italics indicate elevation above sea level of obstruction top. Vertical numerals within parentheses indicate heights above ground)	Reporting Point (Compulsory).....▲
Lighted Obstruction.....▲	Reporting Point (Non-compulsory).....▲
Group Obstruction.....▲	Ocean Station Vessel (Normal position).....
Mooring Mast.....▲	Visual Ground Sign.....[M]
Isogonic Line.....- - - - - 7°E - - - - -	International Boundary (Closed to passage of aircraft except through air corridor).....

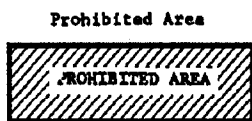

Flight of aircraft prohibited

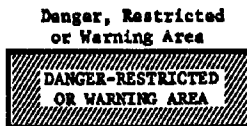

Visible hazards to Air Navigation



Invisible hazards to Air Navigation

ISNP0103

PART 3. HYDROGRAPHIC CHART SYMBOLS

A

THE COASTLINE

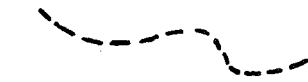

Shoreline unsurveyed



Rocky



Contours



Not rocky, high
Cliffy coastline (Bluffs)



Not rocky, low
Cliffy coastline (Bluffs)



Sandhills or dunes



Stony or shingly shore



Sandy shore



mangrove

Mangrove



Symbol used only
in small areas



marsh

Swamp or marsh

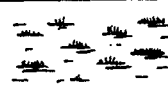

Symbol used only
in small areas

Foreshores

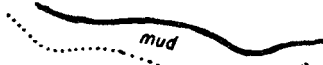

Mud flats



Sand



Stones or gravel



Rock, uncovers at datum
of soundings

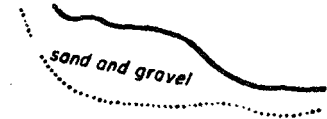

Sand and gravel



Coral, uncovers at datum
of soundings (See DANGERS**)

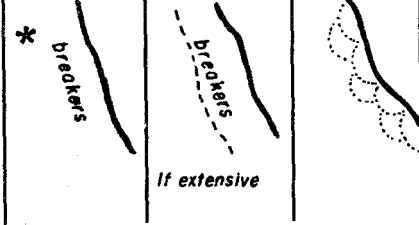

Breakers along a shore

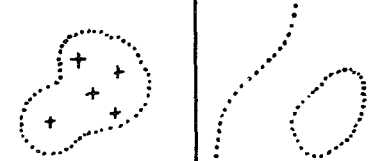

Limiting danger line

ISNP0104







B

COAST FEATURES

G.	Gulf	Mth.	Mouth	Pt.	Point
B	Bay	Rds.	Roads, Roadsteads	Mt.	Mountain
B.	Bayou				Mount
Fd.	Fjord	Anch.	Anchorage	Rge.	Range
L.	Loch, Lough, Lake	Hbr.	Harbor	Pk.	Peak
Cr.	Creek	P	Port	Vol.	Volcano
C.	Cove	P.	Pond	Bld.	Boulder
In.	Inlet	I.	Island	Str.	Stream
Str.	Strait	It.	Islet	R.	River
Sd.	Sound	Arch.	Archipelago	Slu.	Slough
Pass.	Passage, Pass	Pen.	Peninsula	Lag.	Lagoon
Chan.	Channel	C.	Cape	Thoro.	Thoroughfare
Entr.	Entrance	Prom.	Promontory		
		Hd.	Head		

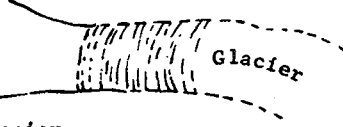

C

THE LAND

 <p>Contours</p>	 <p>Form lines, no definite interval</p>	 <p>Glacier</p> <hr/> <p>Glacier</p> <hr/> <p>○ TREE  </p> <p>A conspicuous clump or single tree of any kind useful as a landmark.</p> <hr/> <p>Isolated trees</p> <hr/> <p>wooded</p> <p>Deciduous woodland</p> <hr/> <p>wooded</p> <p>Coniferous woodland</p> <hr/> <p>2560 T.T.</p> <p>Elevation of top of trees</p>
 <p>Contours, approximate</p>	 <p>Hachures</p>	

D















CONTROL POINTS

<p>△ Triangulation point (station)</p> <p>○ Fixed point</p> <p>•²⁵⁶ Summit of height (Peak) (when not a landmark)</p> <p>²⁵⁶ Peak, accentuated by contours</p>	<p>²⁵⁶ Peak, accentuated by hachures</p> <p> Peak, when elevation has not been determined</p> <p>○²⁵⁶ Peak, when a landmark</p> <p>⊕ Observation spot</p> <p>Obs. Spot</p>	<p>B.M. Bench mark</p> <p>○ see view View point</p> <p>Astro. Astronomical</p> <p>Tri. Triangulation</p> <p>C. of E. Corps of Engineers</p>
---	--	---

ISNP0105

E UNITS					
hr.	hour	in.	inch	lat.	latitude
m, min.	minute	ft.	foot	long.	longitude
sec.	second	yd.	yard	cor.	correction
m.	meter	fm.	fathom	alt.	altitude
km.	kilometer	M.	nautical mile	ht.	height
		kn.	knot		

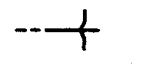
F ADJECTIVES					
gt.	great	concr.	concrete	std.	standard
lrg.	large	bet.	between	subm.	submerged
sml.	small	estab.	established	approx.	approximate
mid.	middle	exper.	experimental	cor.	corner
anc.	ancient	discontd.	discontinued	CL.	clearance
conspic.	conspicuous	fl.	flood	No.	number
dist.	distant	mod.	moderate	Ave.	avenue
abt.	about	maintd.	maintained	Hy.	highway
aband.	abandoned	elec.	electric	explos.	explosive
extr.	extreme	priv.	private, privately	Bldv.	boulevard
		prom.	prominent		

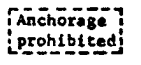
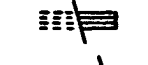
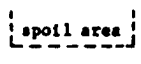
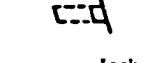
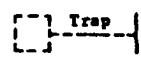
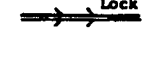
G HARBORS					
	Anch.	Anchorage, large vessels (see section P for anchorage limits)		Fsh. stk.	fishing stakes when dangerous
	Anch.	Anchorage, small vessels		Ldg.	landing place
	Hbr.	Harbor		Dol.	dolphin
	Bkw.	breakwater		Quar.	Quarantine
		jetty (partly below M H W)		Cus. Ho.	Customhouse
		jetty (small scale)		B. Hbr.	Boat Harbor dock
	Pier	pier			dry dock (actual shape shown on large scale charts)
		groin (partly below M H W)			floating dock (actual shape shown on large scale charts)
	Anch. prohib.	Anchorage prohibited			patent slip (marine railway)
		spoil ground		Ramp	ramp
		fish traps (actual shape charted)		Lock	lock (point upstream)
				Obsy.	Observatory

ISNP0106

==== Roads in open country

==== Roads on small scale charts

Roads (Rds.)

----- Track, footpath, or trail

M & N W Ry
or tramway

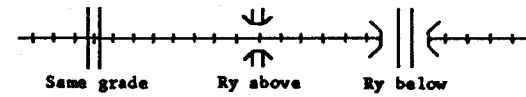

Railway (single or double track)
Railway (Ry.) Railroad (R.R.)

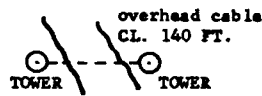

Overhead cable (OVHD. CAB.)



Power transmission line

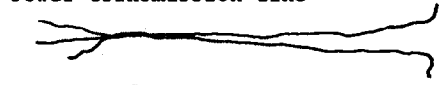

River or Stream

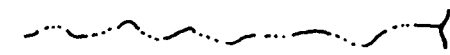

Intermittent stream



Lake (L.)

Marsh (See section A)

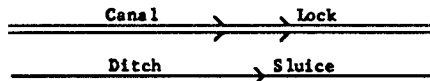

Canal or ditch (point upstream)

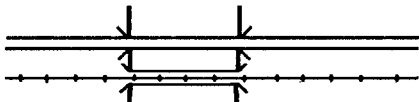

Bridge (fixed) (BR.)

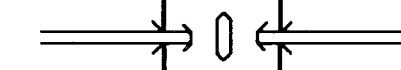

Drawbridge, in general

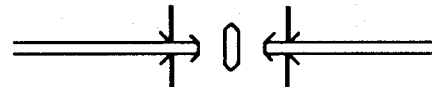

Swing bridge, that can be opened

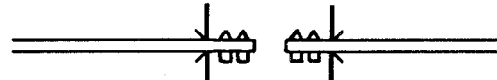

Pontoon bridge, that can be opened

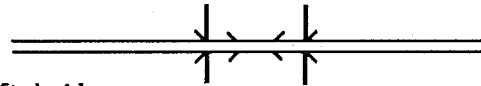

Lift bridge



Bascule bridge, that can be opened



Ferry (Fy.)



Dam

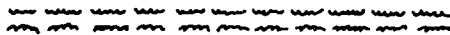

Levee

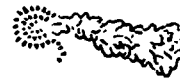

Lava flow



Log boom



Submerged piling, piling,
stumps, and snags

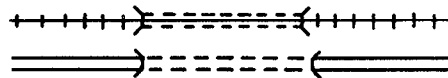

Tunnel (railroad or road)

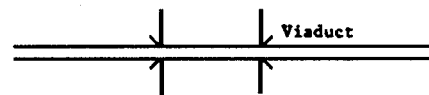

Viaduct

BUILDINGS



When the buildings are prominent, they may be shown by landmark symbol with descriptive note. The landmark symbol is used to indicate positions of objects when accurately determined.

	City or town (large scale)				
	City or town (small scale)				
	Vil.	Village			
	Cas.	Castle			
	Ho.	House			
	Ch.	Church			
		Temple			
		Minaret			
		Mosque			
	Pag.	Pagoda			
	Mony.	Monastery			
	Cem.	Cemetery			
	Ft.	Fort (actual shape charted)			
		Airplane landing field			
		Airport (large scale)			
		Small scale Airport (military)			
		Airport (civil)			
	<u>FIRST ST.</u>	Street			
	Tel.	Telegraph			
	P.O.	Post Office			
	Govt.	Government			
				MON.	Monument
				CUP.	Cupola
				elev.	elevation elevator elevated
				Ruins	Ruins
				TR.	Tower
					Windmill
				CHY.	Chimney
					Oil tank
				Facty.	Factory
				Gab.	Gable
				Sch.	School
				H.S.	High School
				Univ.	University
				Inst.	Institute
				Co.	Company
				Corp.	Corporation
				Cap.	Capital
					Courthouse
				Cath.	Cathedral
				Bldg.	Building
				Pav.	Pavilion
				Ltd.	Limited
				Apt.	Apartment
				T.	Telephone

ISNP0108

J

MISCELLANEOUS STATIONS

Sta.	Station	Sem.	Semaphore
 C. G.	Coast Guard (similar to LS.S.)	○ FS.	Flagstaff
 C G Wallis Sands	When the building is a landmark	○ W B SIG STA	Weather Bureau signal station
 LS.S.	Lifesaving station (similar to C. G.)	○ FP.	Flagpole
	Rkt. Sta. Rocket station	○ F. TR	Flag tower
○ PIL. STA	Pilot station	○ LOOK. TR.	Lookout tower
	Sig. Sta. Signal station	○ S'PIPE	Standpipe
		○ BELL	On land

K

LIGHTS

	Position of light	Rot.	Rotating
*	Lt. Light	M.; min	minutes
*	LH. Lighthouse	SEC.	seconds
* AERO	Aeronautical light	M.	nautical mile
*	Lighted beacon	Gp.	group
*	Lightship	SEC.	sector
*	Lighted buoy	Vi.	violet
*	REF Reflector	Bu.	blue
	Private light	G.	green
* Priv maintd.	(maintained by private interests; to be used with caution)	Or.	orange
F	Fixed	R.	red
Occ.	Occulting	W.	white
F1	Flashing	Am.	amber
Qk F1	Quick flashing	OBSC	obscured
1 Qk	Interrupted quick	(U)	unwatched
Alt	Alternating	Occas	occasional
Gp Occ	Group occulting	Irreg.	irregular
Gp F1	Group flashing	Temp.	temporary
S-L	Short-long	Vert.	vertical
F F1	Fixed and flashing	Hor.	horizontal
F Gp F1	Fixed and group flashing	D.	destroyed
		Extng.	extinguished
		V.B.	vertical beam
		Exper.	experimental
		RGE	range
		AERO	aeronautical

ISNP0109

L

BUOYS AND BEACONS

On entering a channel from seaward, buoys on starboard side are red with even numbers, on port side black with odd numbers. Lights on buoys on starboard side of channel are red or white, on port side white or green. Mid-channel buoys have black and white vertical stripes. Obstruction buoys are green, or have red and black horizontal bands. This system does not always apply to foreign waters. The dot of the buoy symbol, and the small circle of the light vessel and mooring buoy symbols and the center of the beacon symbol indicate their positions.

	Position of buoy		Fish trap buoy (W. & B. H.B.)
	Lighted buoy		Anchorage buoy
	Bell buoy		Maintained by private interests: to be used with caution
	Gong buoy		H.B. Horizontal bands
	Whistle buoy		V.S. Vertical stripes
	Can buoy		Chec. checkered
	Nun buoy		W. white
	Spherical buoy		B. black
	Spar buoy		R. red
	Checkered buoy		Y. yellow
	Lightship		G. green
	Fairway buoy (B. & W. V.S.) (Mid-Channel)		Br. brown
	Junction buoy (R. & B. H.B.)		Gy. gray
	Isolated danger buoy (R. & B. H.B.)		T.B. temporary buoy
	Wreck or obstruction buoy (R. & B.H.B.) or (G.)		Unlighted beacon (Daybeacon)
	Mooring buoy		Bn Beacon (See symbol above)
	Quar. Quarantine buoy		Bn Beacon (See symbol above)
			Landmark
			Landmark, position approx
			Reflector
			Special purpose buoy

Note: Buoy and beacon symbols with topmarks may be shown on charts of foreign waters.

M

RADIO AND RADAR STATIONS

	R. Sta.	Radio station		R. TR (WEAF)	Commercial broadcast
	R.T.	Radio telephone		Ra.	Coast radar station
	R. Bn.	Radiobeacon		Racon	Radar responder beacon
	R.D.F.	Radio direction finder station		Ra. Ref.	Radio reflector
	R. TR.	Radio tower		Ra.(conspic.)	Radar conspicuous object
	R. MAST	Radio mast		Ramk.	Ramark

ISNP0110

















N

FOG SIGNALS

Fog Sig.	Fog signal station	DIA.	Diaphone	WHIS.	Fog whistle
SUB-BELL	Submarine fog bell (mechanical)	SIREN	Fog siren	REED	Reed horn
SUB-OSC.	Submarine oscillator	HORN	Fog trumpet	GONG	Gong
NAUTO.	Nautophone	HORN	Fog horn	D.F.S.	Distance finding station
		BELL	Fog bell	GUN	Fog gun

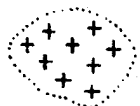
O

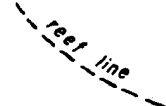
DANGERS

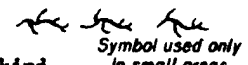
 (29) Rocks which do not cover, with their elevations above M.H.W.		 Stranded wreck (any portion of hull above datum of soundings)			
* uncovers 2 ft * (2) Rocks that cover and uncover, with heights in feet above datum of soundings		 masts Sunken wreck with only masts visible			
 When preceding rock is considered a danger to navigation		 Dangerous sunken wreck with less than 10 fathoms of water over it (See DANGERS †)			
+ Sunken rock		 wreckage A number of sunken wrecks			
 When preceding rock is considered a danger to navigation		 21 Obstr Obstruction of any kind			
 2 Rk Shoal sounding on isolated rock replaces symbol		 5 1/2 wreck Wreck of known depth			
† [21] Rk [21] Wk [21] Obstr Sunken danger with depth cleared by wire drag (Feet or fathoms)		 Sunken wreck, not dangerous to surface navigation or over which the depth exceeds 10 fathoms			
 [21] Rk [21] Wk [21] Obstr Sunken danger with depth cleared by wire drag (Feet or fathoms)		 foul Foul ground			
 Coral or rocky reef (below datum of soundings) See COASTLINE **		Tide rips  Symbol used only in small areas Overfalls or tide rips			
 reef line		Eddies Eddies			
 Coral or rocky reef (below datum of soundings) See COASTLINE **		Kelp  Symbol used only in small areas Kelp, any kind			
Bk.	Bank	breakers (See COASTLINE *)	cov. uncov.	covers uncovers reported	Discol. discolored
Shl.	shoal	Obstr.	Rep.	shoal reported	P.A. position approximate
Rf.	reef	Wk.	Shoal (rep 1945)		P.D. position doubtful
Le.	ledge	Wks.			E.D. existence doubtful
					Pos. position

ISNP0111

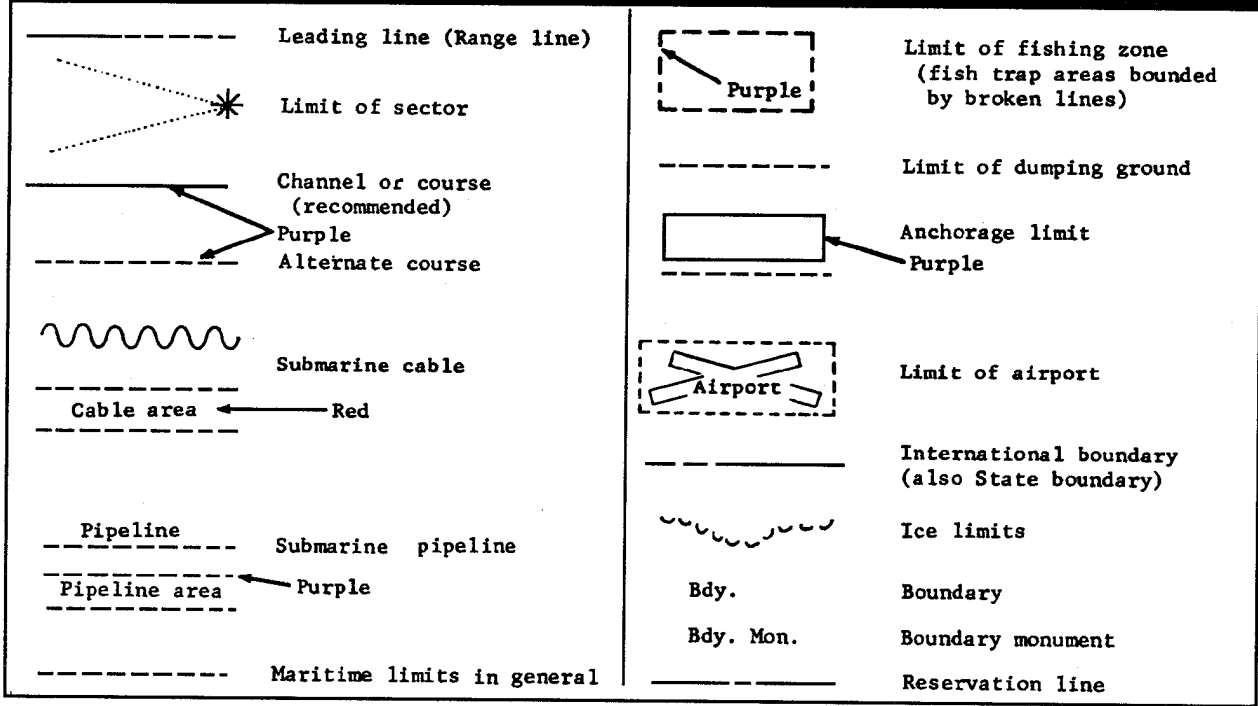
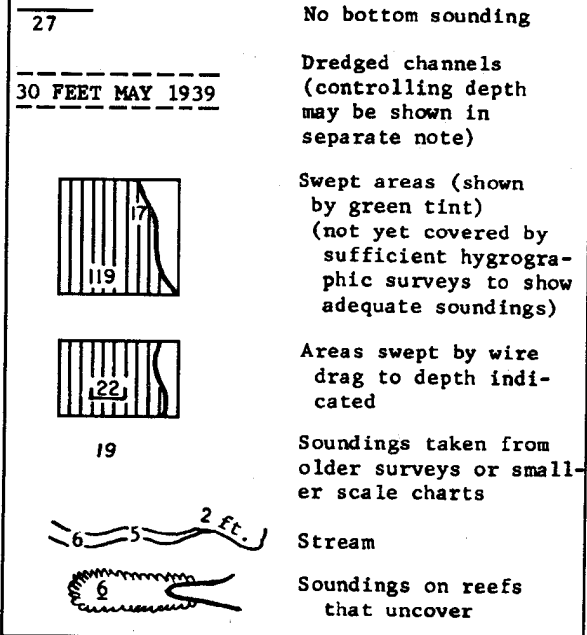
P**VARIOUS LIMITS****Q****SOUNDINGS****R****DEPTH CONTOURS AND TINTS**

Feet	Fathoms	
0	0	
6	1	
12	2	
18	3	
24	4	
30	5	
36	6	
60	10	
120	20	
180	30	
240	40	
300	50	
600	100	
1,200	200	
1,800	300	
2,400	400	
3,000	500	
6,000	1,000	
12,000	2,000	
18,000	3,000	
Or 10 fathoms and greater		-----10----- or ---100---(blue)

ISNP0112

S

QUALITY OF THE BOTTOM

Grd.	ground	T.	tufa	sml.	small
S.	sand	Sc.	scoriae	lrg.	large
M.	mud	Cn.	cinders	stk.	sticky
Oz.	ooze	Mn.	manganese	brk.	broken
Ml.	marl	Sh.	shells	rky.	rocky
Cl.	clay	Oys.	oysters	spk.	speckled
G.	gravel	Ms.	mussels	gty.	gritty
Sn.	shingle	Spg.	sponge	fly.	flinty
P.	pebbles	Grs.	grass	glac.	glacial
St.	stones	Wd.	weeds	wh.	white
Sp.	specks	Fr.	foraminifera	bk.	black
Rk.	rock	Gl.	globigerina	bu.	blue
Bld. (s)	boulder (s)	Di.	diatom	gn.	green
Ck.	chalk	Rd.	radiolaria	yl.	yellow
Qz.	quartz	Pt.	pteropod	rd.	red
Co.	coral	Po.	polyzoa	br.	brown
Co. Hd.	coral head	fne.	fine	gy.	gray
Md.	madrepore	crs.	coarse	lt.	light
Vol. Ash.	volcanic ash	sft.	soft	dk.	dark
La.	lava	hrd.	hard	Ca.	calcareous
Pm.	pumice	stf.	stiff		

T

TIDES AND CURRENT

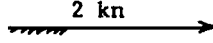
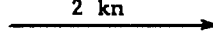
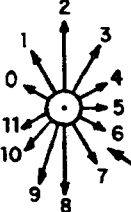
H.W.	high water	Str.	stream
H.H.W.	higher high water		current, general
L.W.	low water		flood stream
L.L.W.	lower low water		ebb stream
M.T.L.	mean tide level	vel.	velocity
M.S.L.	mean sea level	kn	knots
Sp.	spring tide		
Np.	neap tide		
M.H.W.	mean high water		
M.H.H.W.	mean higher high water		
M.L.W.	mean low water		
M.L.L.W.	mean lower low water		
I.S.L.W.	Indian spring low water		

Current Diagram, with explanatory note

Purple

ISNP0113

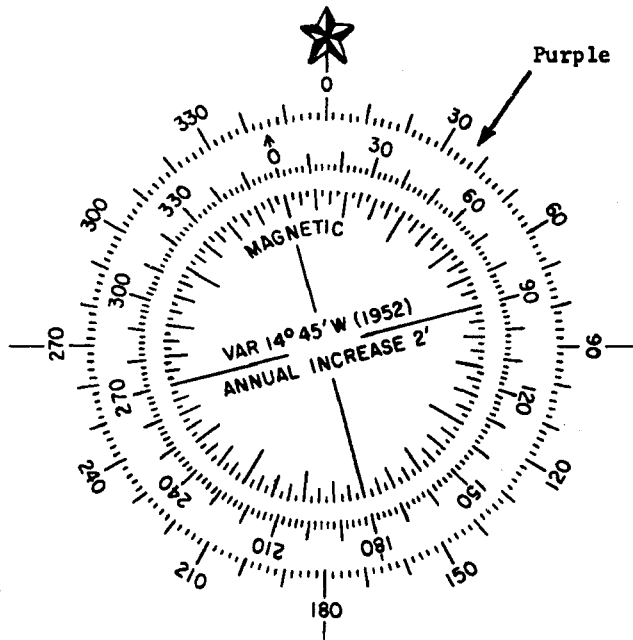
U**COMPASS**

Compass Rose

The outer circle is in degrees with zero at true north. The inner circles are in points and degrees with the arrow indicating magnetic north.

N.	north
E.	east
S.	south
W.	west
NE.	northeast
SE.	southeast
SW.	southwest
NW.	northwest
brg.	bearing
mag.	magnetic
var.	variation
deg.	degrees
dev.	deviation

ISNP0114

APPENDIX VI

REFERENCES USED TO DEVELOP THIS TRAMAN

Chapter 1

Department of the Navy Information and Personnel Security Program Regulation, OPNAVINST 5510.1H, Chief of Naval Operations, Washington, DC, 1988.

Manual of Navy Enlisted Manpower and Personnel Classifications and Occupational Standards, NAVPERS 18068F, Chief of Naval Personnel, Washington, DC, 1992.

Chapter 2

Intelligence Specialist 1 & C, NAVEDTRA 12806, Naval Education and Training Program Management Support Activity, Pensacola, 1995.

National Maritime Intelligence Center, Organizational Directory, NMIC Directory, Office of Naval Intelligence, Washington, DC, 1994.

Naval Component Intelligence Tactics, Techniques, and Procedures, Navy Component TTP, Secretary of the Navy, Washington, DC, 1994.

Naval Intelligence, Naval Doctrine Publication 2, Secretary of the Navy, Washington, DC, 1994.

P-3 Tactical Manual, NWP 55-2-P3 (now NWP 3-20.5), Chief of Naval Operations, Washington, DC, 1993.

Tactical Airborne Information Document (U), TACAID For ASW Aircraft, NWP 55-2-2 (now NWP 3-21.61), Chief of Naval Operations, Washington, DC, 1992.

Chapter 3

Afloat Supply Procedures, NAVSUP Publication 485, Naval Supply Systems Command, Naval Supply Systems Command, Washington, DC, 1995.

Coordinated Shipboard Allowance List, SPCCINST 4441.170A, Navy Ships Parts Control Center, Mechanicsburg, PA, 1989.

Department of the Navy Automatic Data Processing Security Program, OPNAVINST 5239.1A, Chief of Naval Operations, Washington, DC, 1985.

Department of the Navy Correspondence Manual, SECNAVINST 5216.5C, Secretary of the Navy, Washington, DC, 1983.

Department of the Navy Directives Issuance System, SECNAVINST 5215.1C, Secretary of the Navy, Washington, DC, 1970.

Department of the Navy Information and Personnel Security Program Regulation, OPNAVINST 5510.1H, Chief of Naval Operations, Washington, DC, 1988.

Department of the Navy Records Management Program, SECNAVINST 5210.8C, Secretary of the Navy, Washington, DC, 1989.

Department of the Navy Standard Subject Identification Codes, SECNAVINST 5210.11D, Secretary of the Navy, Washington, DC, 1987.

Military Requirements for Petty Officer Third Class, NAVEDTRA 12044, Naval Education and Training Program Management Support Activity, Pensacola, FL, 1991.

The Naval Warfare Publication System, NWP 1-01, Chief of Naval Operations, Washington, DC, 1994.

Navy and Marine Corps Records Disposition Manual, SECNAVINST 5212.5C, Secretary of the Navy, Washington, DC, 1985.

Radioman Communications, NAVEDTRA 12801, Naval Education and Training Program Management Support Activity, Pensacola, FL, 1994.

Standard Navy Distribution List, OPNAV P09B2-105(94), Chief of Naval Operations, Washington, DC, 1994.

U.S. Navy Distribution Procedures for COMTAC and Joint Doctrine Publications, OPNAVINST 5605.19J, Chief of Naval Operations, Washington, DC, 1993.

Chapter 4

Access to and Dissemination of Restricted Data, DOD Directive 5210.2, Department of Defense, Washington, DC, 1994.

Communications Security Material System (CMS) Policy and Procedures Manual, CMS 1, Director, Communications Security Material System, Washington, DC, 1993.

Department of the Navy Freedom of Information Act (FOIA) Program, SECNAVINST 5720.42E, Secretary of the Navy, Washington, DC, 1993.

Department of the Navy Information and Personnel Security Program Regulation, OPNAVINST 5510.1H, Chief of Naval Operations, Washington, DC, 1988.

Manual of the Judge Advocate General, JAGINST 5800.7C, Office of the Judge Advocate General, Alexandria, VA 1990.

Chapter 5

Catalog of Maps, Charts, and Related Products, Pt 1-Aerospace Products, Volume 1, Defense Mapping Agency, Bethesda, MD, 1994.

Military Symbols, FM 21-30, Department of the Army, Washington, DC, 1970.

Chapter 6

Aerial Photography and Airborne Sensor Imagery (Forwarding Titling and Plotting), DIAM 55-5, Defense Intelligence Agency, Washington, DC, 1986.

Air Reconnaissance Manual, NWP 25-3 (now NWP 3-55.11), Chief of Naval Operations, Washington, DC, 1990.

DIA Fact Book—Communist World Forces, DST-2660Z-013-88, Defense Intelligence Agency, Washington, DC, 1988.

Fleet Intelligence Collection Manual, ONI-2600Z-001-95, Office of Naval Intelligence, Washington, DC, 1995.

Imagery Requirements Manual, DIAM 58-5, Defense Intelligence Agency, Washington, DC, 1993.

Joint Imagery Interpretation Keys Structure (JIIKS), Vol XII, Military Aircraft of the World, DIAM 57-7 (series), Defense Intelligence Agency, Washington, DC, 1975-1990.

Merchant Marine Identification Guide—World, ONI-2050G-001-90, Office of Naval Intelligence, Washington, DC, 1990.

Naval Intelligence Products Register (NIPR), ONI-2600A-0001-93, Office of Naval Intelligence, Washington, DC, 1993.

Reconnaissance Reference Manual, NAVAIR 10-1-789, Commander Naval Air Systems Command, Washington, DC, 1983.

Chapter 7

Intelligence Specialist 3 and 2, Volume 2, NAVEDTRA 10272, Naval Education and Training Program Management Support Activity, Pensacola, FL, 1986.

Chapter 8

Data Processing Technician Second Class, NAVEDTRA 12511, Naval Education and Training Program Management Support Activity, Pensacola, FL, 1991.

Data Processing Technician 3 and 2, NAVEDTRA 12513, Naval Education and Training Program Management Support Activity, Pensacola, FL, 1995.

INDEX

A

Aerial photograph, 6-19
 camera types, 6-20
 FLIR, 6-24
 IR, 6-24
 mapping and charting, 6-22
 maritime surveillance, 6-22
 radarscope, 6-23
 reconnaissance, 6-22
 titling of imagery, 6-28

Aids to interpretation, 6-5
 comparative imagery, 6-7
 magnification, 6-7
 parallax, 6-6
 photo overlap, 6-7
 reference materials, 6-8
 stereoscopy, 6-5

Air intelligence, 2-2, 2-10 to 2-12
 air patrol operations, 2-11
 carrier air operations, 2-11
 helicopter operations, 2-12
 strike warfare, 2-11

Aircraft reconnaissance capabilities,
 6-26
 F-14 Tomcat, 6-26
 future developments, 6-28
 P-3C, 6-28
 S-3A Viking, 6-27
 TARPS, 6-27

Amphibious intelligence, 2-12

Amphibious operations, 2-12 to 2-13

Antisubmarine warfare (ASW), 2-13

Approach to interpretation, 6-8
 cursory search, 6-8
 identification and analysis, 6-8
 reports of findings, 6-8

Arbitrary grids, 5-20
 Thrust-Line Reference System, 5-21

Automated information systems (MS),
 3-4

B

Basic imagery recognition, 6-30
 aircraft, 6-37
 helicopters, 6-42
 merchant ships, 6-37
 missiles, 6-43
 naval forces, 6-30

Battle damage assessment (BDA), 2-14

Billets, 1-2

C

Camera, 6-9
 filters, 6-12
 focal length, 6-11
 identification, 6-26
 lens, 6-9
 reproduction, 6-14
 sensitized materials, 6-13
 shutter, 6-10
 terminology, 6-9

Classification authority, 4-9
 derivative classification authority, 4-12
 original classification authority, 4-9

Classified information categories, 4-5
 Confidential, 4-6
 For Official Use Only, 4-6
 Secret, 4-6
 Top Secret, 4-5

Classified information accountability and control,
 3-43

AIS materials, 3-45
 care during working hours, 3-46
 care after working hours, 3-46
 code words, 3-45
 Confidential, 3-45
 custody, 3-45
 microform, 3-45
 Secret, 3-44
 Top Secret, 3-43 to 3-44
 working papers, 3-45

- Classified information markings, 4-6
 - marking components, 4-9
 - Classified material destruction, 3-50
 - emergency plans, 3-51
 - procedures and reports, 3-50
 - Classified material disposition, 3-49
 - Classified material storage, 3-49
 - Classified material transmission, 3-46
 - COMSEC material, 3-48
 - Confidential, 3-47
 - preparation, 3-48
 - Restricted Data, 3-48
 - Secret, 3-47
 - Top Secret, 3-46
 - Combat search and rescue (CSAR), 2-14
 - Combinations, 4-20
 - change procedures, 4-20
 - record of change, 4-20
 - Commander's Preparation of the Battlespace (CPB), 2-7
 - Computer hardware, 8-1
 - CD-ROM, 8-8
 - CPU, 8-2
 - disks and drives, 8-4
 - input/output devices, 8-2
 - modem, 8-9
 - monitor, 8-4
 - mouse, 8-8
 - printers, 8-6
 - scanner, 8-8
 - switch box, 8-9
 - tape drive, 8-8
 - Computer setup and operation, 8-9
 - directories, 8-12
 - disk and file management, 8-11
 - DOS extensions, 8-11
 - troubleshooting, 8-13
 - using documentation, 8-9
 - Control of dissemination, 4-12
 - Restricted or Formerly Restricted Data, 4-12
 - retired or reserve personnel, 4-12
 - Secret or Confidential, 4-12
 - Top Secret material, 4-12
 - Coordinated Shipboard Allowance List (COSAL), 3-2
 - Copy machines, 3-5
 - Correspondence, 3-16
 - classification markings, 3-16
 - memorandum, 3-20
 - naval letters, 3-16
 - point paper, 3-20
- D**
- Database organization methods/structures, 8-21
 - Defense Mapping Agency (DMA), 5-36
 - Destruction of classified ADP material, 4-18
 - clearing and declassifying ADP media, 4-18
 - Directives Issuance System, 3-14
 - disposition, 3-16
 - requisitioning, 3-16
 - types, 3-15
 - Distance measurements, 7-6
 - Duty assignments, 1-3
- E**
- Electronic calculators, 7-10
 - Essential Elements of Information, 2-3 to 2-4
- F**
- Facsimile (Fax) machines, 3-5
- G**
- Geographic coordinates, 5-9
 - azimuth system, 5-13
 - cardinal point system, 5-12
 - declination diagram, 5-15
 - direction, 5-12
 - latitude, 5-10
 - longitude, 5-11
 - mil system, 5-13
 - Global Navigational and Planning Chart (GNC), 5-31
 - Graphic scale, 5-8
 - words and figures, 5-9
 - Greenwich mean time (GMT) system, 5-28
 - date-time group, 5-29
 - time zones, 5-28

- Grid coordinates, 5-16
- H**
- Height determination, 7-7
 - obtaining height from shadows, 7-9
 - relief displacement method, 7-7
 - terms, 7-7
- I**
- Imagery files and systems, 6-14
 - DIWSA, 6-17
 - hard-copy film, 6-18
 - IDEX II, 6-15
 - JDISS, 6-14
 - JSIPS-N, 6-17
 - MATRIX, 6-15
 - NIEWS, 6-15
 - PIES, 6-17
 - PPDB, 6-17
 - retrieval methods, 6-18
- Imagery intelligence, 6-2
 - advantages, 6-2
 - disadvantages, 6-2
- Imagery interpretation, 6-1
 - data analysis, 6-3
 - functions, 6-2
 - fusion analysis, 6-3
- Information security program, 4-1
 - definitions, 4-2 to 4-4
 - purpose, 4-2
- Intelligence, 1-1, 2-2
 - collectors, 2-2
 - producers, 2-3
 - vendors, 2-3
- Intelligence charts, 5-38
 - annotations, 5-40
 - collecting materials, 5-40
 - mounting procedures, 5-38
 - prepare surface, 5-40
- Intelligence cycle, 2-3
 - collection, 2-4
 - dissemination, 2-6
 - planning and direction, 2-3 to 2-4
 - Intelligence cycle—Continued
 - processing, 2-4 to 2-5
 - production, 2-5
- Intelligence division, 2-8 to 2-9
- Intelligence files, 3-7
- Intelligence photography, 6-18
 - annotating, 6-53
 - collection, 6-19
 - overlays, 6-54
 - reproduction, 6-54
 - still photography, 6-18
 - types of coverage, 6-19
- Intelligent Preparation of the Battlespace (IPB), 2-7
- Intelligence schools, 1-3
- Intrusion detection systems, 4-19
 - activation and deactivation, 4-20
 - testing, 4-20
- J**
- Jet Navigation Chart (JNC), 5-31
- Joint Intelligence Centers (JIC), 2-10
- Joint Operations Graphic-Air, Series 1501 (JOG-AR), 5-31
- L**
- Light tables, 6-48
 - cleaning procedures, 6-48
- M**
- Maintenance Data Subsystem (MDS), 3-4
- Map overlays, 5-32
 - instruction materials, 5-34
 - military symbols, 5-33
 - preparation, 5-34
 - types, 5-33
- Map projections, 5-1
 - azimuthal equidistant, 5-6
 - gnomonic, 5-6
 - Lambert conformal conic, 5-2
 - Mercator, 5-2
 - polar stereographic projection, 5-4
 - Transverse Mercator, 5-4

- Map scale, 5-7
 - representative fraction(RF) or ratio, 5-7
- Marginal information, 5-24
 - contour lines, 5-26
 - form lines, 5-26
 - glossary, 5-26
 - hachures, 5-27
 - identification, 5-25
 - relief, 5-26
 - scale, 5-26
 - shading, 5-28
 - source information, 5-25
 - spot elevations, 5-28
 - symbols, 5-24
 - tint system, 5-28
- Measuring devices, 7-3
- Mensuration, 7-1
- Messages, 3-20
 - address indicating groups (AIG), 3-33
 - address groups, 3-32
 - call signs, 3-34
 - classes of naval messages, 3-25
 - collective address designator (CAD), 3-34
 - COMMSPOT reports, 3-30
 - drafter, 3-37
 - JCS emergency action messages, 3-31
 - message and routing addressees, 3-32 & 3-35
 - message text format (MTF), 3-38
 - movement reports, 3-31
 - originator, 3-37
 - paragraph markings, 3-40
 - prosigns, 3-36
 - readdressals, 3-40
 - references, 3-40
 - releaser, 3-38
 - routing indicators, 3-35
 - subject line markings, 3-40
 - types, 3-26
 - verification, 3-38
- Metric system, 7-10
- Microfiche, 3-4 to 3-5
- MILSTRIP, 3-2
- Mosaics, 6-49
 - annotating, 6-53
 - controlled, 6-50
- Mosaics—Continued
 - materials, 6-52
 - mounting, 6-50
 - reproduction, 6-54
 - semicontrolled, 6-51
 - uncontrolled, 6-49
- N**
- National Imagery and Mapping Agency (NIMA), 5-36
 - requisitioning NIMA products, 5-36
 - stowing maps and charts, 5-38
- Naval special warfare (NSW), 2-14
- Naval Warfare Publication Library (NWPL), 3-12
 - binders, 3-12
 - changes, 3-14
 - inventories, 3-14
 - NWP format, 3-12
 - work in the NWPL, 3-12
- Navy Enlisted Classifications (NECs), 1-3
- Navy staff, 2-8
- O**
- Ocean Surveillance Information System (OSIS), 2-10
- Operational intelligent, 2-1
- Operational Navigation Chart (ONC), 5-31
- Overhead projector, 3-5 to 3-6
- P**
- Personnel security investigations (PSIs), 4-4
- Photo imagery characteristic, 6-3
- Printing maps, 8-24
- Publications and directives, 3-11
 - inventory procedures, 3-11 to 3-12
 - ordering, 3-11
- R**
- Records, 3-8
 - defining, 3-10
 - disposal, 3-8

Records—Continued
disposition, 3-10 to 3-11
reviewing, 3-1

Requesting imagery, 6-29
authorization, 6-29
procedures, 6-29

Requirements Control Authority (RCA), 2-2

Requisitioning supplies, 3-2

S

Sanitization of working spaces, 4-17

Sanitizing classified material, 4-17

Scale determination, 7-1
representative fraction, 7-2
terms, 7-4

Scale, methods, 7-4
comparison, 7-6
recognition, 7-5

Security violations and compromises, 4-14
action required, 4-14
cryptographic keying material, 4-15
cryptographic material, 4-15
disposition of the record of investigation, 4-15
record of investigation, 4-14
report of previously lost classified material,
4-16
security violations, 4-15

Slide projectors, 3-6

Software packages, 8-13
database organization, 8-21
databases, 8-18
spreadsheets, 8-17
using, 8-14
utilities, 8-22
virus utilities, 8-24

Software packages—Continued
word processing, 8-15

Special photo reconnaissance, 6-25
ground photography, 6-29
night photograph, 6-25
periscope photography, 6-30

Standard Subject Identification Codes (SSIC), 3-7
to 3-8

Statement of Intelligent Interest, 2-3

Stowing supplies, 3-3

Strategic intelligence, 2-1

Subversion of military personnel, 4-16

T

Tactical intelligence, 2-2

Tactical Pilotage Chart (TPC), 5-31

Topographic map, 5-31

Tracking files, 3-8

Types of clearance, 4-4

Typewriters, 3-4

U

Universal Reference Grid (URG) System, 5-20

Universal Transverse Mercator (UTM) Grid Sys-
tem, 5-16

V

Video cassette recorder (VCR), 3-7

W

World Geographic Reference (GEOREF) System,
5-22

Assignment Questions

Information: The text pages that you are to study are provided at the beginning of the assignment questions.

ASSIGNMENT 1

Textbook Assignment: "The Intelligence Specialist," and "Intelligence Fundamentals"; chapters 1 and 2, pages 1-1 through 2-14, and Appendices II and III.

1-1. Which of the following is a basic skill of an Intelligence Specialist?

1. Planning missions
2. Analyzing threats
3. Interpreting images
4. Each of the above

1-2. Since the fall of the former Soviet Union, the intelligence gathering methods of the IS have changed drastically.

1. True
2. False

1-3. A complete list of the Occupational Standards for Intelligence Specialist is contained in what publication?

1. NAVEDTRA 10500
2. NAVPERS 18068
3. NAVEDTRA 10455
4. NAVPERS 16068

- | |
|--|
| <ol style="list-style-type: none">A. IMAGE INTERPRETATIONB. SCI WATCHSTANDINGC. INTELLIGENCE SUPPORT TO SURFACE SHIPSD. OPERATES UNDER DHS SYSTEME. DOCUMENT SS0 PROCESSES |
|--|

Figure 1A

Figure 1A.-Billet responsibilities.

IN ANSWERING QUESTIONS 1-4 THROUGH 1-6, SELECT FROM FIGURE 1A THE RESPONSIBILITY THAT CORRESPONDS TO THE BILLET DESCRIBED BELOW.

1-4. The OPINTEL billet.

1. B
2. C
3. D
4. E

1-5. The image interpreter billet.

1. A
2. B
3. D
4. E

1-6. The attache billet.

1. A
2. B
3. C
4. D

1-7. Satellite sensor interpretation is associated which of the following NECs?

1. 3901
2. 3910
3. 3923
4. 3824

1-8. To be qualified as an OSIS Baseline Upgrade (OBU) user or analyst, you need which of the following NECs?

1. 3901
2. 3905
3. 3907
4. 3922

- 1-9. NTCS-A Strike Planning Applications Analyst is associated with what NEC?
1. 3910
 2. 3922
 3. 3923
 4. 3924
- 1-10. To be qualified to run the Digital Imagery Workstation Suite Afloat, you should have what NEC?
1. 3910
 2. 3925
 3. 3901
 4. 3905
- 1-11. Intelligence knowledge is generally divided into what two broad categories?
1. Subject and application
 2. Military and industrial
 3. Military and political
- 1-12. A new air-to-air defensive tactic employed by foreign fighter aircraft is most correctly referred to as what type of intelligence?
1. Operational intelligence
 2. Combat intelligence
 3. Air intelligence
 4. Strategic intelligence
- 1-13. What category of intelligence is concerned with specific fleet collection opportunities and procedures?
1. Operational intelligence
 2. Air intelligence
 3. Strategic intelligence
 4. Combat intelligence
- 1-14. Which of the following is NOT one of the five phases of the intelligence cycle?
1. Processing
 2. Planning and direction
 3. Interpretation
 4. Dissemination
- 1-15. What is the highest level Requirements Control Authority for the management of military intelligence?
1. CIA
 2. DIA
 3. NSA
 4. NFIB
- 1-16. Which of the following modes is/are commonly used for expressing requirements for intelligence information?
1. Collection Support Requirement (CSR)
 2. Statement of Intelligence Interest (SII)
 3. Essential Elements of Information (EEI)
 4. All of the above
- 1-17. What publication provides procedures for establishing a SII?
1. DIAR 13-2
 2. DIAM 58-1
 3. DIAR 59-1
 4. DIAM 58-13
- 1-18. Intelligence availability is described as the determination of whether the information is already available on file.
1. True
 2. False
- 1-19. During which phase of the intelligence cycle is information converted into usable intelligence?
1. Collection
 2. Production
 3. Processing
 4. Dissemination

1-20. During which phase of intelligence production does the analyst make a judgement concerning the factual accuracy of the information he/she is producing?

1. Receiving/retrieving of information
2. Evaluation of information
3. Production guidance
4. Integration of information

1-21. The orderly identification of needed information and the assigning of tasks are parts of which phase of the intelligence cycle?

1. Processing
2. Production
3. Collection
4. Planning and direction

1-22. Translation, film development of tactical reconnaissance, and conversion are all parts of which phase of the intelligence cycle?

1. Processing
2. Production
3. Collection
4. Dissemination

1-23. Which of the following is NOT an advantage of written dissemination?

1. The content usually doesn't change during transmission
2. The report can be reproduced and sent to many users
3. Electronic transmission helps to communicate rapidly
4. A permanent record is not required

1-24. Communication to a prospective user in a timely manner is considered part of which dissemination criterion?

1. Clarity
2. Accuracy
3. Security
4. Urgency

1-25. Which of the following statements pertains to a record of dissemination?

1. It is a listing of intelligence information recipients
2. It is a listing of intelligence participants
3. It is used to control intelligence information
4. It is used to determine who should receive intelligence information

1-26. Naval intelligence is designed to support which of the following actions/activities?

1. Operations at sea
2. Operations from the sea
3. Joint and national intelligence centers
4. All of the above

1-27. Which of the following terms is described as the systematic and continuous analysis of the adversary?

1. Commander's Preparation for the Battlespace (CPB)
2. Intelligence Preparation of the Battlespace (IPB)
3. Crisis response
4. Force projection

- 1-28. On a Navy staff, logistics are the direct responsibility of which office?
1. N-1
 2. N-2
 3. N-3
 4. N-4
- 1-29. The intelligence officer is normally subordinate to and reports directly to what officer?
1. Operations officer
 2. Executive officer
 3. Commanding officer
 4. Communications officer
- 1-30. Who is responsible for determining that current map and chart allowances are on hand in a given unit?
1. The intelligence division petty officer
 2. The operations officer
 3. The intelligence officer
 4. The supply officer
- 1-31. The Division Chief and Division Petty Officers are generally selected on the basis of what characteristic?
1. Knowledge
 2. Experience
 3. Responsibility
 4. Seniority
- 1-32. Limited OPINTEL processing in the 1970's was due in part to which of the following problems?
1. Lack of trained personnel
 2. Communications limitations
 3. Lack of equipment
- 1-33. Which of the following is NOT a responsibility of the theater JIC?
1. Escape and evasion studies
 2. Threat analysis
 3. Supply requisition
 4. I&W support
- 1-34. What program allows intelligence reserve units to work on various support projects for JICs?
1. Fleet Project Program
 2. Freedom of Information Act
 3. Congressional Support Project
- 1-35. What term is applied to intelligence produced to support the formulation of tactics used to counter the effectiveness of air-to-surface missiles?
1. Missile intelligence
 2. Air intelligence
 3. Combat intelligence
 4. Strategic intelligence
- 1-36. The destruction or neutralization of enemy targets ashore can best be described as what type of warfare?
1. Strike warfare
 2. Anti-submarine warfare
 3. Amphibious warfare
 4. Naval special warfare
- 1-37. The function of performing shipping surveillance from an airborne platform can best be accomplished by which of the following aircraft?
1. F/A-18
 2. F-14
 3. KC-135
 4. P-3C

- 1-38. Intelligence developed in support of helicopter landing operations must contain the absolute latest information concerning which of the following factors?
1. Escape and evasion
 2. Cover and concealment
 3. Helicopter landing zone obstacles
 4. All of the above
- 1-39. Amphibious operations may be conducted for which of the following purposes?
1. For additional combat operations
 2. To secure an area for a naval or air base
 3. To deny use of an area to the enemy
 4. All of the above
- 1-40. The majority of intelligence functions are performed during which phase of an amphibious operation?
1. Assault
 2. Planning
 3. Rehearsal
 4. Movement to the objective area
- 1-41. Swift incursion into or a temporary occupation of an objective followed by a planned withdrawal is known by what term?
1. Amphibious raid
 2. Non-combat evacuation
 3. Amphibious demonstration
 4. Amphibious withdrawal
- 1-42. Antisubmarine Standing Intelligence is related to the current activities of enemy submarines.
1. True
 2. False
- 1-43. The initial phase of ASW operations results in the classification of an underwater contact.
1. True
 2. False
- 1-44. As soon as a contact is classified as a possible, probable, or certain submarine, the ASW unit will begin the attack phase.
1. True
 2. False
- 1-45. Which of the following strike warfare mission areas is associated with Naval Special Warfare?
1. Close air support
 2. Fleet reconnaissance
 3. Gun fire support
 4. Beacon emplacement
- 1-46. Which intelligence organization is most closely related to the Executive Office of the President of the United States?
1. The Federal Bureau of Investigation
 2. The Department of Defense
 3. The Central Intelligence Agency
 4. The National Security Council
- 1-47. Which of the following individuals functions in an advisory capacity to the National Security Council?
1. The Secretary of Defense
 2. The Chairman, Joint Chiefs of Staff
 3. The Director, Federal Bureau of Investigation
 4. The Secretary of State

- 1-48. Which of the following officials may be appointed by the President as an additional member of the National Security Council?
1. The Secretary of State
 2. The Executive Secretary
 3. The Secretary of the Navy
 4. The Secretary of Defense
- 1-49. Recommendations to the President of the United States relating to overall international security policy and political/military affairs originate with the
1. Central Intelligence Agency
 2. Joint Chiefs of Staff
 3. Secretary of Defense
 4. National Security Council
- 1-50. Which of the following individuals/organizations serve(s) as the intelligence staff to the Joint Chiefs of Staff?
1. The commanders of the military services
 2. The Defense Intelligence Agency
 3. The National Security Council
 4. The Central Intelligence Agency
- 1-51. The foreign intelligence efforts of the United States armed services are coordinated by what individual?
1. Secretary of Defense
 2. Chairman, Joint Chiefs of Staff
 3. Assistant Secretary of Defense (Intelligence)
 4. Director, Central Intelligence Agency
- 1-52. What organization has complete responsibility for COMSEC, SIGINT, and counterintelligence processing?
1. National Security Agency
 2. Central Intelligence Agency
 3. Defense Intelligence Agency
 4. Federal Bureau of Investigation
- 1-53. Which of the following is NOT a function of the National Military Joint Intelligence Center?
1. Indications and Warning
 2. Targeting support
 3. Database management
 4. Ocean surveillance
- 1-54. The intelligence functions required of the Chief of Naval Operations are performed by what individual or agency?
1. Director, Naval Intelligence
 2. Defense Intelligence Agency
 3. Marine Corps Intelligence Activity
 4. Commander, Naval Security Group
- 1-55. What organization or individual is charged with directing and managing maritime intelligence activities to fulfill intelligence requirements and responsibilities assigned by the DCI?
1. Office of Naval Intelligence
 2. Central Intelligence Agency
 3. Defense Intelligence Agency
 4. Commander, Naval Security Command

- 1-56. The Strike and Air Warfare department are part of which ONI directorate?
1. ONI-1
 2. ONI-2
 3. ONI-3
 4. ONI-5
- 1-57. The programs which monitor the maritime shipment of goods to identify illicit cargoes fall under which ONI directorate?
1. ONI-2
 2. ONI-3
 3. ONI-5
 4. ONI-6
- 1-58. What ONI directorate provides collection sensors, communications systems, and associated operational support to fleet and U.S. command users?
1. ONI-3
 2. ONI-5
 3. ONI-6
 4. ONI-7
- 1-59. Which organization maintains, commands, and operates a worldwide structure to fulfill the investigative and counterintelligence responsibilities of the DON?
1. Defense Investigative Service
 2. Defense Intelligence Agency
 3. Naval Criminal Investigative Service
 4. Federal Bureau of Investigation
- 1-60. Which of the following departments includes the SABER shop?
1. Integration and Regional Analysis
 2. Surface and Coastal Warfare
 3. Strike and Air Warfare
 4. Undersea Warfare
- 1-61. Which of the following commands within the National Maritime Intelligence Center focuses on crisis and predeployment support to expeditionary warfare?
1. Commander, Naval Security Group
 2. Marine Corps Intelligence Activity
 3. Coast Guard Intelligence Coordination Center
- 1-62. The Army Chief of Staff for Intelligence has which of the following responsibilities?
1. Coordinating combat intelligence
 2. Directing the Army mapping program
 3. Directing the Army geodesy program
 4. All of the above
- 1-63. Counterintelligence functions fall under which Army intelligence element?
1. Intelligence and Security Command (INSCOM)
 2. Intelligence and Threat Analysis Center (ITAC)
 3. Foreign Science and Technology Center
 4. Missile and Space Intelligence Center

- 1-64. Which Air Force intelligence element is responsible for HUMINT collection?
1. Electronics Security Command
 2. Air Force Special Activities Center (AFSAC)
 3. Foreign Technology Division
 4. Office of Special Investigations (OSI)
- 1-65. Which of the following government agencies has jurisdiction over investigations dealing with espionage?
1. The Central Intelligence Agency
 2. The Federal Bureau of Investigation
 3. The Defense Investigative Service
 4. The State Department
- 1-66. Within the INR, which section is responsible for long range analytical studies?
1. Current Analysis
 2. Coordination
 3. Office of Intelligence Support
 4. Assessments and Research
- 1-67. The Defense Attaché System is under the direct authority of the Director, Defense Intelligence Agency.
1. True
 2. False
- 1-68. The Defense Attaché is charged to direct, control, operate, and administer the DAO, with the exception of the service attaché.
1. True
 2. False
- 1-69. The service attaché will collect and report intelligence information as required by current DIA directives.
1. True
 2. False
- 1-70. Within the British Intelligence service, MI-5 most closely resembles which U.S. intelligence organization?
1. Defense Intelligence Agency
 2. Central Intelligence Agency
 3. Federal Bureau of Investigation
 4. Bureau of Alcohol, Tobacco, and Firearms
- 1-71. Within the French intelligence system, who is responsible for overseas covert activities?
1. SDECE
 2. DGSE
 3. Second Directorate of the National Defense Staff
- 1-72. Within the Israeli intelligence organization, who is responsible for counterintelligence?
1. Central Institute for Intelligence and Security
 2. Intelligence Corps of the Defense Forces
 3. Special Investigations
 4. Shin Bet
- 1-73. Within the Russian intelligence system, who is responsible for SIGINT activities?
1. SVR
 2. FAPSI
 3. FSB
 4. KGB

1-74. Counterintelligence is the responsibility of which Russian intelligence service?

1. FSB
2. SVR
3. KGB
4. GRU

1-75. Which of the following is NOT an element of the Chinese intelligence system?

1. The Board of Regents
2. The State Council
3. The Military Establishment
4. The Ministry of Foreign Affairs

ASSIGNMENT 2

Textbook Assignment: "Technical Administration"; chapter 3, Pages 3-1 through 3-26.

- 2-1. If your command is operating under manual supply procedures, what form should you use to order supplies for your office?
1. DD Form 458
 2. NAVSUP Form 1250-1
 3. NAVSANDA Form 28
 4. NAVPERS Form 1626/7
- 2-2. For complete instructions in ordering supplies and examples of supply requisition forms, you should consult what publication?
1. Coordinated Shipboard Allowance List
 2. NAVSUP Publication 441
 3. Financial Management in the Navy
 4. NAVSUP Publication 485
- 2-3. Which of the following actions is NOT considered a good practice in the procurement and stowage of supplies?
1. Checking supplies at regular intervals
 2. Stockpiling supplies as they become available
 3. Labeling contents of wrapped packages with colored pens
 4. Opening only one package of each kind of material
- 2-4. What is the result of wastefulness within an intelligence office?
1. A surplus of supplies
 2. A lack of needed supplies
 3. Always having new stock available
 4. Unlimited replenishment items
- 2-5. AISs support which of the following applications?
1. Word processing
 2. Spread sheets
 3. Database management
 4. All of the above
- 2-6. If your office typewriter has a reoccurring fault, you should
1. continue to fix it yourself
 2. contact the servicing agent
 3. notify your PMS coordinator
 4. continue to use it, even if the type is unreadable
- 2-7. What advantage does a microfiche reader-printer have over a microfiche reader?
1. The display unit is larger
 2. The operating features are easier
 3. The print size is larger
 4. A permanent copy can be made

- 2-8. Unlimited use of a copy machine by personnel may result in which of the following situations?
1. Quick, easy reproduction of uncontrolled classified material
 2. Latent impressions left on reproduction equipment
 3. Excessive waste which can lead to compromise
 4. Each of the above
- 2-9. Which of the following precautions should you follow when you send secure information over a fax machine?
1. Request permission from the command secretary
 2. Notify your leading chief
 3. Consult the security manager to ensure that all procedures are met
- 2-10. Which of the following benefits pertain(s) to the overhead projector?
1. One person may operate the projector
 2. The lights need not be turned off in the room
 3. Both 1 and 2 above
 4. The transparencies may be used on a carousel
- 2-11. When you are using an overhead projector located behind a screen, how should you place the transparencies on the projector?
1. Face down, unreadable to the operator
 2. Face up, readable to the operator
 3. Face down, readable to the operator
 4. Face up, unreadable to the operator
- 2-12. For which of the following briefings are 35mm slide presentations best suited?
1. Tactical
 2. Formal
 3. Informal
 4. Field
- 2-13. What is/are the primary reason(s) for mounting the slide tray on top of the projector?
1. To change slides quickly
 2. To keep track of the slide that is being shown
 3. Both 1 and 2 above
 4. To provide jam-proof operation
- 2-14. Which of the following advantages pertains to using VCRs?
1. To allow for real-time analysis
 2. To allow expeditious dissemination of information
 3. Both 1 and 2 above
 4. To provide an interactive format
- 2-15. The purpose of the Standard Navy File System is to ensure that all general files have the same basic arrangement.
1. True
 2. False

- 2-16. The filing procedures within any naval activity depend on which of the following factors?
1. The mission of the activity and the volume of correspondence
 2. The size and mission of the activity
 3. The location of the activity and the volume of correspondence
 4. The size and location of the activity
- 2-17. Information relating to the Navy standard file maintenance procedures is contained in which of the following publications?
1. SECNAVINST 5215.1
 2. OPNAVINST 5510.1
 3. SECNAVINST 5210.11
 4. OPNAVINST 5510.49
- 2-18. How many major subject groups are used for classifying and filing Navy records?
1. 14
 2. 13
 3. 12
 4. 11
- 2-19. A Navy letter carries the standard subject identification code number 3010. What is the major subject code area of the letter?
1. Military Personnel
 2. Telecommunications
 3. Intelligence
 4. Operations and Readiness
- 2-20. Material relating to intelligence should be filed in what standard file series?
1. 1000
 2. 2000
 3. 3000
 4. 4000
- 2-21. A major group may be divided into how many subdivisions?
1. One
 2. Two
 3. Three
 4. Four
- 2-22. What is the primary use for the "File Out Card" (NAVEXOS 4178)?
1. To record the contents of a file
 2. To record the name and location of the person borrowing the file
 3. To record the nature of the material that has been permanently removed from the file
 4. To maintain a record of oversized material transferred to a bigger cabinet
- 2-23. Who establishes laws and regulations governing the disposition of official naval records?
1. The Congress
 2. The Secretary of Defense
 3. The Secretary of the Navy
 4. The Chief of Naval Operations
- 2-24. Retention standards for official U.S. Navy records are contained in which of the following publications?
1. BUPERSINST 5212.16
 2. SECDEFINST 5211.10
 3. SECNAVINST 5212.5
 4. OPNAVINST 5215.5

- 2-25. Nonrecord materials may consist of which of the following types of materials?
1. Extra file copies
 2. Rough drafts
 3. Trade journals
 4. Each of the above
- 2-26. Which of the following methods is used to dispose of local records?
1. Local destruction
 2. Transferring for future destruction
 3. Transferring for preservation
 4. Each of the above
- 2-27. At sea, you should dispose of unclassified records by which of the following methods?
1. Shredding and dumping overboard
 2. Dumping overboard intact
 3. Burning
 4. Each of the above
- 2-28. Which of the following forms is used as a transmittal document for records shipped to a Federal Records Center?
1. Standard Form 135
 2. NAVEXOS Form 4065
 3. DD Form 155
 4. OPNAV Form 5215
- 2-29. Indefinite or permanent retention of official records falls under what category?
1. Retention
 2. Preservation
 3. Compilation
- 2-30. IS personnel have which of the following responsibilities in handling official publications?
1. Stowing them properly
 2. Maintaining a checkoff system to ensure their use by authorized personnel only
 3. Locating them when requested to do so
 4. Each of the above
- 2-31. Which of the following methods may be used to make changes and corrections to publications?
1. Inserting new pages
 2. Making pen-and-ink changes
 3. Removing obsolete pages
 4. Each of the above
- 2-32. Which of the following publications should you consult for information on inventory procedures for classified publications?
1. OPNAVINST 5510.49
 2. OPNAVINST 5510.1
 3. SECNAVINST 5215.12
 4. SECNAVINST 5511.2
- 2-33. Which of the following publications contains the current allowance for units of the operating forces?
1. OPNAVINST 5605.19
 2. NAVEDTRA 10237
 3. NWP 1-01
 4. SNDL
- QUESTIONS 2-34 THROUGH 2-38 PERTAIN TO THE COLORS ASSOCIATED WITH NWPL BINDERS.
- 2-34. Which color corresponds to Top Secret material?
1. Blue
 2. White
 3. Red
 4. Pink

- 2-35. Which color corresponds to Confidential material?
1. Blue
 2. Yellow
 3. Pink
 4. Red
- 2-36. Which color corresponds to NATO or AP type publications?
1. White
 2. Blue
 3. Red
 4. Yellow
- 2-37. Which color corresponds to Unclassified material?
1. White
 2. Blue
 3. Red
 4. Yellow
- 2-38. Which color corresponds to Secret material?
1. White
 2. Blue
 3. Red
 4. Yellow
- 2-39. What action involving the catalog card is required each time a publication is returned to the NWPL?
1. The person returning the publication should sign the catalog card
 2. A new catalog card should be prepared
 3. A person working in the NWPL should sign the catalog card in the presence of the person returning the publication
 4. The catalog card should be destroyed in the presence of the person returning the publication
- 2-40. When changes or corrections to publications held in the NWPL are received, how or when should they be entered?
1. They should be entered on the effective date
 2. They should be inserted into the publication, and the first person to use the publication should enter them
 3. They should be entered as soon as possible and a note should be made indicating the effective date
 4. They should be filed separately with a note in the publication indicating what changes issued
- 2-41. As the NWPL clerk, you receive a change to a publication that is held in the command's communications center. What action(s) should you take with regard to the change?
1. Recall the publication from the communications center
 2. Have the communications center make the change
 3. Both 1 and 2 above
 4. Retain the change until the publication is returned
- 2-42. Which of the following forms may be used to record changes to NWPs?
1. OPNAV 5070/11
 2. FM 258
 3. DD Form 1170
 4. OPNAV 5070/12

- 2-43. Information concerning the organization and the procedures governing the NWPL is contained in which of the following publications?
1. OPNAVINST 5070.1
 2. NWP 1-01
 3. OPNAVINST 5605.19
 4. NTP 3
- 2-44. Which of the following statements concerning inventories of the NWPL NOT correct?
1. All publications in the NWPL must be inventoried at least once annually
 2. An informal report of the inventory must be submitted to the commanding officer
 3. Upon change of the NWP custodian, all publications in the NWPL should be inventoried
 4. Communications publications held in the NWPL should be inspected every six months
- 2-45. Which of the following publications contains guidance concerning the preparation of an instruction?
1. SECNAVINST 5215.1
 2. SECNAVINST 5210.2
 3. OPNAVINST 5215.1
 4. OPNAVINST 5210.2
- 2-46. Navy directives are used to convey information regarding
1. policy and organization matters of a continuing nature only
 2. methods and procedures of a one-time nature only
 3. methods and procedures of a continuing nature only
 4. policy, organization, methods, and procedures of a one-time and continuing nature
- 2-47. Unless an instruction states otherwise, it is automatically canceled 6 months after the date it was issued.
1. True
 2. False
- 2-48. What is the maximum period of time that a notice may remain in effect?
1. 1 month
 2. 6 months
 3. 3 months
 4. 12 months
- 2-49. The overall management of the Directives Issuance System within the Navy is the responsibility of what authority?
1. CNO
 2. SECNAV
 3. SECDEF
 4. CHNAVPERS

- 2-50. You have been directed to order several additional copies of an instruction that your command holds. From what officer or activity should you order the copies?
1. The stocking point shown on the instruction
 2. Commander, Naval Supply System Command
 3. Commanding Officer, Naval Publications and Forms Center
 4. The originator of the instruction
- 2-51. How are instructions ordered from the Aviation Supply Office, Philadelphia, PA?
1. By two-way memo
 2. By form letter
 3. By computer-based program, via modem
 4. By NAVSUP Form 1205
- 2-52. What publication should you consult concerning formatting instructions for a naval letter?
1. SECNAVINST 5216.5
 2. SECNAVINST 5215.1
 3. OPNAVINST 5510.1
 4. OPNAVINST 5510.49
- 2-53. If your correspondence is classified, what publication should you consult for preparation procedures?
1. SECNAVINST 5216.5
 2. SECNAVINST 5215.1
 3. OPNAVINST 5510.1
 4. OPNAVINST 5510.49
- 2-54. A brief form of naval correspondence that an official uses to either comment on or forward a letter is called a/an
1. memorandum
 2. endorsement
 3. business letter
 4. point paper
- 2-55. What is the correct order of the items in the heading of a naval letter?
1. From, To, Via, Subj, Ref, Encl
 2. From, To, Subj, Via, Ref, Encl
 3. From, To, Ref, Subj, Via, Encl
 4. To, From, Subj, Ref, Via, Encl
- 2-56. Correspondence used to communicate with persons or agencies outside of the Department of Defense is known by what term?
1. Memorandum
 2. Endorsement
 3. Business letter
 4. Point paper
- 2-57. Which of the following formats provides an informal way to correspond within an activity?
1. Memorandum
 2. Endorsement
 3. Business letter
 4. Point paper
- 2-58. Which of the following types of memoranda is considered to be more formal?
1. Printed form
 2. Plain paper
 3. Letterhead
 4. Memorandum for

- 2-59. A brief summary of information and facts that provide the reader with a concise statement is called a/an
1. memorandum
 2. endorsement
 3. point paper
 4. business letter
- 2-60. Tabs on a point paper should normally be listed in which of the following ways?
1. Alphabetically, lower left-hand corner of the first page
 2. Numerically, lower left-hand corner of the first page
 3. Alphabetically, lower right-hand corner of the first page
 4. Numerically, lower right-hand corner of the first page
- 2-61. Automatic Digital Network (AUTODIN) message procedures and formats are identical to those used in radiotelephone procedures.
1. True
 2. False
- 2-62. Of the DTGs listed below, which one correctly indicates the 22nd day of August, 1997 at 1327 Greenwich mean time?
1. 22 AUG 97, 1327
 2. 132722Z AUG 97
 3. 221327Z AUG 97
 4. 221327 AUG 97
- 2-63. To indicate the desired writer-to-reader delivery time, message precedence categories have been established. How many such categories are there?
1. Five
 2. Six
 3. Three
 4. Four
- 2-64. As fast as possible with an objective of less than 10 minutes corresponds to which speed-of-service objective?
1. FLASH
 2. IMMEDIATE
 3. PRIORITY
 4. ROUTINE
- 2-65. A speed-of-service objective of 3 hours corresponds to which precedence category?
1. FLASH
 2. IMMEDIATE
 3. PRIORITY
 4. ROUTINE
- 2-66. A speed-of-service objective of 6 hours corresponds to which precedence category?
1. FLASH
 2. IMMEDIATE
 3. PRIORITY
 4. ROUTINE
- 2-67. A speed-of-service objective of 30 minutes corresponds to which precedence category?
1. FLASH
 2. IMMEDIATE
 3. PRIORITY
 4. ROUTINE
- 2-68. Of the three special-handling markings, which one is associated with SIOP-ESI information?
1. SPECAT
 2. LIMDIS
 3. PERSONAL FOR
 4. NOTAL
- 2-69. Which special-handling marking is associated with special projects, cover names, or specific subjects?
1. SPECAT
 2. LIMDIS
 3. PERSONAL FOR
 4. NOTAL

2-70. Information that falls into one of several nuclear-oriented subject matter categories is considered to be what type of data?

1. Unrestricted
2. Radiological
3. Restricted

QUESTIONS 2-71 THROUGH 2-75 RELATE TO CLASSES OF NAVY MESSAGES.

2-71. Which class of message deals with broadcast traffic in special forms, such as hydrographic data?

1. Class A
2. Class C
3. Class D
4. Class E

2-72. What class of messages accounts for the largest volume of traffic handled by the Navy?

1. Class A
2. Class B
3. Class C
4. Class D

2-73. What message class includes personal messages sent to and from naval personnel, free of charge over naval circuits?

1. Class A
2. Class C
3. Class D
4. Class E

2-74. What message class includes private messages for which the Navy collects a toll?

1. Class A
2. Class B
3. Class D
4. Class E

2-75. What message class includes official messages originated by and destined for U.S. Government agencies other than those in DOD?

1. Class B
2. Class C
3. Class D
4. Class E

ASSIGNMENT 3

Textbook Assignment: "Technical Administration (continued)," and "Security"; chapters 3 and 4, pages 3-26 through 4-5.

- 3-1. Which of the following is NOT a general message?
1. ALNAV
 2. NAVOP
 3. JAFPUB
 4. CRITIC
- 3-2. Which of the following identification numbers is used in the 26th ALCOM for calendar year 1997?
1. ALCOM 026/97
 2. ALCOM 26-1997
 3. ALCOM 026/17 MAY 97
 4. ALCOM 26-05/17/97
- 3-3. What is the effective time limit, if any, on a general message that does NOT have a cancellation date?
1. The current and the next calendar years
 2. One year from the DTG
 3. Ninety days from the DTG
 4. None
- 3-4. What is the normal precedence applied to AMCROSS messages?
1. ROUTINE
 2. PRIORITY
 3. IMMEDIATE
 4. FLASH
- 3-5. For detailed information on commercial communications, you should consult which of the following publications?
1. NWP 1-01
 2. NTP 9
 3. ACP 12
 4. NTP 3
- 3-6. What are the distinguishing characteristics, if any, of pro forma messages?
1. They are serialized and bear the activity's UIC
 2. The text is preset and cannot be changed by the originator
 3. They do not require a DTG
 4. None
- 3-7. What is the purpose of MINIMIZE?
1. To lower the precedence of all messages
 2. To indicate an emergency
 3. To clear user circuits for essential traffic
 4. To reduce the length of messages by using abbreviations
- 3-8. Which of the following publications should you consult for information on traffic that may be sent over normal channels and circuits during MINIMIZE?
1. NTP 9
 2. NWP 0-01
 3. NTP 3
 4. NWP 6-01
- 3-9. Which type of message deals with corrections, repetitions, broadcast reruns, and misrouted or missent messages?
1. Tracer
 2. Service
 3. Communication Guard Shift
 4. COMMSPOT

- 3-10. Which type of message is sent to determine the reason for nondelivery of a message previously sent?
1. Tracer
 2. Service
 3. Q message
 4. COMMSPOT
- 3-11. Which of the following messages is used when a command moves its guard from one broadcast center to another?
1. Tracer
 2. Service
 3. Communications guard shift
 4. COMMSPOT
- 3-12. Which of the following messages is used to advise of any situation that might cause significant disruption of tactical communications?
1. Service
 2. Tracer
 3. Q message
 4. COMMSPOT
- 3-13. Which of the following messages provides the Worldwide Military Command and Control System with ship location information?
1. COMMSPOT
 2. JCS EAM
 3. MOVREP
 4. NOTAM
- 3-14. Which of the following messages are the classified portions of allied navigational warning messages?
1. Q Messages
 2. Hydrographic messages
 3. NOTAMs
 4. MOVREPs
- 3-15. Which of the following messages are extremely time-sensitive, and usually carry a FLASH precedence?
1. MOVREPs
 2. NOTAMs
 3. JCS Ems
 4. COMMSPOTs
- 3-16. Which of the following messages is used to ensure the safety and accountability of submarines?
1. Hydrographic message
 2. Submarine check report
 3. MOVREP
 4. NOTAM
- 3-17. Which of the following messages is concerned with the safety of airmen?
1. MOVREP
 2. NOTAM
 3. COMMSPOT
 4. LOCATOR
- 3-18. Which of the following message reports may include such information as casualties to various types of navigational aids; marine, air, or submarine disasters; and search and rescue?
1. Hydrographic messages
 2. NOTAMs
 3. LOCATORS
 4. Q messages
- 3-19. Which of the following messages has two or more addressees, action or information, and a section informing each addressee of all other recipients?
1. Single-address message
 2. Multiple-address message
 3. Book message
 4. General message

- 3-20. Which of the following messages has a wide, predetermined, standard distribution?
1. Single-address message
 2. Multiple-address message
 3. Book message
 4. General message
- 3-21. Which of the following address groups is used to support two or more commands or activities?
1. Individual activity, address group
 2. Collective address group
 3. Geographic address group
 4. Address indicator group
- 3-22. What minimum number of addressees must you in order to have a valid AIG?
1. 11
 2. 12
 3. 16
 4. 18
- 3-23. In which of the following publications should you find a complete listing of AIGs by number, cognizant authority, and purpose?
1. NTP 3 SUPP-1
 2. ACP 100 U.S. SUPP-1
 3. NTP 3
 4. WP 11
- 3-24. Which of the following designations gives special instructions and must always be encrypted?
1. AIG
 2. CAD
 3. ACP
 4. SOG
- 3-25. The CAD is a single-address group that represents a set of four or more activities, including the cognizant authority.
1. True
 2. False
- 3-26. ACP 113 provides a listing of which of the following types of call signs?
1. Military
 2. International
 3. Collective
 4. Each of the above
- 3-27. The MAD is divided into how many sections?
1. Five
 2. Two
 3. Three
 4. Seven
- 3-28. Which of the following statements is true concerning PLADs?
1. Absolute consistency in format and spelling is not critical for processing
 2. Absolute consistency in format and spelling is critical for processing
 3. Human interface is no longer required to process PLADs
 4. PLADs are only necessary for overseas assignments
- 3-29. When a plain language address is spelled, AIG 64 should appear in which of the following ways?
1. AIG 6-4
 2. AIG 64
 3. AIG SIX FOUR
 4. AIG SIXTY FOUR

- 3-30. What designation must be used if the office code of the addressee is unknown?
1. JJJ
 2. UUU
 3. 000
 4. ???
- 3-31. Letters or combinations of letters that convey frequently sent orders or instructions are identified by what term?
1. Call signs
 2. Road signs
 3. Prosigns
 4. Office codes
- 3-32. Which of the following prosigns corresponds to the designation "AS"?
1. Beginning
 2. Ending
 3. Separation
 4. Pause
- 3-33. Which general prosign designation corresponds to the term "Interrogative"?
1. INT
 2. IMI
 3. NR
 4. INR
- 3-34. Which of the following designations is assigned to the authority in whose name the message is sent?
1. Processor
 2. Originator
 3. Drafter
 4. Releaser
- 3-35. The MSGID "GENADMIN" identifies what type of formatted message?
1. MTF
 2. CAD
 3. Pro forma
- 3-36. Which of the following statements best describes a linear set?
1. It consists of data fields and one or more data fields in a horizontal manner
 2. It consists of a set identifier followed by a single unformatted narrative
 3. It is a discrete block of information in a horizontal manner
- 3-37. Which set identifier is used when another document or conversation is associated with a message?
1. REF
 2. AMPN
 3. SUBJ
 4. ASSOC
- 3-38. Which of the following publications is used to identify paragraph markings for telecommunications traffic?
1. NTP 3
 2. NTP SUPP-1
 3. ACP 113
 4. OPNAVINST 5510.1
- 3-39. What type of message is used to send a message to an addressee not on the original message?
1. Service
 2. Readdressal
 3. Tracer
 4. NOTAM

- 3-40. With the exception of material containing a distribution list by copy number, a phrase such as "Copy No. 2 of 3 copies" must appear on documents bearing what classification?
1. Top Secret
 2. Secret
 3. Confidential
 4. Each of the above
- 3-41. When a Top Secret document is sent to another command for retention, the disclosure form is removed and retained for what minimum period of time?
1. Six months
 2. One year
 3. Two years
 4. Five years
- 3-42. A signed receipt is not required for Secret material when it is routed to which of the following activities?
1. An activity within the Department of the Navy
 2. An activity within the Defense Intelligence Agency
 3. Another office within the command
 4. All of the above
- 3-43. Top Secret material must be inventoried, audited, and otherwise accounted for at what maximum interval?
1. Monthly
 2. Semiannually
 3. Annually
 4. Weekly
- 3-44. Who within the Department of the Navy may assign code words?
1. Director of Central Intelligence
 2. Chief of Naval Operations
 3. Director of Naval Intelligence
 4. Commandant of the Marine Corps
- 3-45. Working papers may be retained for what maximum period before they must be entered into the control system?
1. 30 days
 2. 45 days
 3. 60 days
 4. 90 days
- 3-46. What publication provides guidance on controlling and safeguarding classified magnetic media?
1. OPNAVINST 5239.1
 2. SECNAVINST 5215.2
 3. COMNAVSECGRUINST S5510.1
 4. NTP 3
- 3-47. Which of the following security measures should you take to prevent compromise of classified information?
1. When you vacate your space during working hours, stow all classified matter to prevent unauthorized disclosure
 2. When you vacate your space, ensure that all classified matter is either stowed or destroyed
 3. When classified documents are at your desk but not in use, keep them either face down or covered
 4. Each of the above

- 3-48. A properly cleared and designated contractor employee may transmit Top Secret material within which of the following territorial limits?
1. United States only
 2. United States and its territories only
 3. United States and Canada only
 4. United States, U.S. territories, and Canada
- 3-49. What category of mail should be used to transmit a Secret letter within the United States?
1. Registered mail
 2. Certified mail
 3. First class mail
 4. Air mail
- 3-50. In what chapter of the Security Manual should you find information on transmitting Confidential material through the U.S. Postal Service?
1. 11
 2. 14
 3. 15
 4. 17
- 3-51. Transmission requirements for COMSEC material are contained in which of the following publications?
1. CMS 1
 2. CMS 3
 3. OPNAVINST 5239.1
 4. ACP 122
- 3-52. In what type of container should classified material be enclosed when sent through the U.S. mail?
1. A single opaque envelope clearly marked with the highest classification
 2. A single opaque envelope with no markings
 3. Two opaque envelopes, the inner one clearly marked with the highest classification
 4. Two opaque envelopes, both clearly marked with the highest classification
- 3-53. For an official listing of fleet and mobile units, you should refer to which section(s) of the SNDL?
1. Part 1
 2. Part 2
 3. Both 1 and 2 above
 4. Part 3
- 3-54. A document bearing which of the following classifications must be covered by a continuous chain of receipts?
1. Formerly Restricted Data
 2. Confidential
 3. Secret
 4. Top Secret
- 3-55. Completed postcard receipt forms for classified material must be kept on file for what minimum period of time?
1. Six months
 2. One year
 3. Two years
 4. Five years

3-56. Which, if any, of the following materials may be stored in a safe containing classified material?

1. Money
2. Jewels
3. Narcotics
4. None of the above

3-57. By which of the following methods should you dispose of classified materials no longer needed by your office?

1. Return them to the originator
2. Forward them to a Federal records center
3. Destroy them locally
4. Either 2 or 3 above, depending on content and classification

3-58. In addition to burning, which of the following methods may be used to destroy classified material?

1. Shredding only
2. Pulping and shredding only
3. Pulverizing and pulping only
4. Pulping, pulverizing, and shredding

3-59. How many witnessing officials must observe the authorized destruction of Top Secret material?

1. Five
2. Two
3. Three
4. Four

3-60. Destruction certificates for classified documents must be retained at the command performing the destruction for what minimum period of time?

1. One month
2. Two months
3. One year
4. Two years

3-61. If classified equipment is to be sunk at sea, in what minimum depth should it be jettisoned?

1. 600 fathoms
2. 1,000 fathoms
3. 1,500 fathoms
4. 2,000 fathoms

A.	Documents classified Secret Special Access
B.	COMSEC material classified Top Secret
C.	Operating schedules classified Confidential Special Access
D.	Tactical plans classified Top Secret
E.	Descriptions of plans classified Top Secret Special Access

Figure 3A

IN ANSWERING QUESTION 3-62, REFER TO FIGURE #A.

3-62. In what order, based on highest to lowest security level, should these items be destroyed when an emergency warrants such action?

1. E, D, B, A, C
2. E, A, C, D, B
3. B, E, D, A, C
4. B, E, A, E, C

- 3-63. What official is directly responsible to the Secretary of the Navy for policies relating to the security of classified information in the Department of the Navy?
1. Chief of Information
 2. Director, Defense Intelligence Agency
 3. Director of Naval Intelligence
 4. Chief of Naval Operations
- 3-64. Within the DON, who is primarily responsible for seeing that the Navy's Information Security Program is effective and follows directives issued by higher authority?
1. Chief of Information
 2. Director, Defense Intelligence Agency
 3. Director of Naval Intelligence
 4. Chief of Naval Operations
- 3-65. Which of the following publications prescribes the procedures to be followed in safeguarding classified information?
1. DOD Directive 5300.2
 2. SECNAVINST 5400.6
 3. OPNAVINST 5510.1
 4. DIAINST 5840.12
- 3-66. Which of the following descriptions best defines the term "access"?
1. The ability to obtain knowledge of classified information only
 2. The opportunity and ability to obtain knowledge of classified information
 3. A place where classified information is kept
 4. Taking possession of classified information
- 3-67. Which of the following materials may be classified?
1. Documents
 2. Products
 3. Substances
 4. Each of the above
- 3-68. What term is defined as the exposure of classified information to an unauthorized person?
1. Disclosure
 2. Compromise
 3. Declassification
 4. Improper transmission
- 3-69. Based on the need-to-know policy of the information security program, who is responsible for determining that an individual who has an adequate security clearance should be granted access to a specific document?
1. The person requesting access to the document
 2. The prospective recipient's immediate supervisor
 3. The possessor of the document
 4. The security manager of the command

3-70. What does the term "clearance," as used in the Information Security Program Regulation, describe?

1. The eligibility for access to information classified at a specific level of classification
2. The eligibility for access to all classified information dealing with a specific subject
3. The necessity for access to classified information on a specific subject
4. The authority to classify information on a specific classification category

3-71. What is the primary difference between an interim security clearance and a final security clearance?

1. An interim security clearance provides for access to classified information; a final security clearance establishes a need to know
2. An interim security clearance provides a temporary eligibility for access to classified information; a final security clearance is granted upon completion of all investigative requirements
3. An interim security clearance is granted to military personnel when they enter service; a final security clearance is granted after 2 years of honorable active service
4. An interim security clearance is granted to an individual who cannot meet the requirements for a final security clearance

3-72. What is the maximum amount of time that an interim clearance may remain in effect?

1. 6 months, unless extended by the CO
2. 1 year
3. 2 years
4. As long as necessary

3-73. Which of the following types of security investigations is/are used in the Navy?

1. National Agency Check
2. Special Investigative Inquiry
3. Single Scope Background Investigation
4. All of the above

3-74. Which chapter of the Security Manual governs requesting a security investigation?

1. 15
2. 17
3. 21
4. 28

3-75. Which of the following forms is used for fingerprint information?

1. FD Form 258
2. DD Form 398
3. SF 86
4. SF 85P

ASSIGNMENT 4

Textbook Assignment: "Security (continued)," and "Mapping, Charting, and Geodesy"; chapters 4 and 5, pages 4-5 through 5-14.

4-1. Which of the following forms replaces the DD 398 Personal Security form?

1. SF 86
2. DD 1879
3. SF 700
4. DD 1148

4-2. Which of the following commands is the adjudication authority for requesting SSBIs and SSBI-PRs for access to SCI?

1. COMNAVSECGRU
2. OPNAV
3. DON CAF
4. SECNAV

4-3. To what authority should a completed SSBI-PR investigative request package be sent?

1. Commander, Naval Security Group
2. Director, National Security Agency
3. Director or Naval Intelligence
4. Personnel Investigations Center, Defense Investigative Service

4-4. What total number of DD 1879 forms must be included in an SSBI investigative package?

1. 1
2. 3
3. 5
4. 10

4-5. Aboard ship, who usually controls access and accountability of SCI billets?

1. Operations department
2. Supply department
3. Strike Operations
4. Communications department

4-6. Into how many categories is security information classified, and what are those categories?

1. Four: Top Secret, Secret, Confidential, and Restricted
2. Four: Top Secret, Secret, Confidential, and For Official Use Only
3. Three: Top Secret, Secret, and Confidential
4. Three: Top Secret, Secret, and Restricted

QUESTIONS 4-7 THROUGH 4-9 PERTAIN TO CLASSIFICATION CATEGORIES AND ASSOCIATED LEVELS OF DAMAGE CAUSED BY UNAUTHORIZED DISCLOSURE.

4-7. For which category would unauthorized disclosure likely cause "damage" to national security?

1. Restricted
2. Confidential
3. Secret
4. Top Secret

- 4-8. For which category would unauthorized disclosure likely cause "exceptionally grave damage" to national security?
1. Restricted
 2. Confidential
 3. Secret
 4. Top Secret
- 4-9. For which category would unauthorized disclosure likely cause "serious damage" to national security?
1. Restricted
 2. Confidential
 3. Secret
 4. Top Secret
- 4-10. What publication should you consult for guidance on the Freedom of Information Act and the use of the FOUO marking?
1. SECNAVINST 5720.42
 2. OPNAVINST 5510.11
 3. SECNAVINST 5215.2
 4. OPNAVINST 5510.29
- 4-11. A classification marking on material serves which of the following purposes?
1. It indicates the assigned classification
 2. It makes known the required level of protection
 3. It designates information that must be kept from unauthorized persons
 4. All of the above
- 4-12. Normally, what color ink should be used to stamp the classification marking on a document?
1. Black
 2. Blue
 3. Red
 4. Green
- 4-13. The inside pages of a classified document are marked to indicate the highest classification level of what information?
1. Information in the document
 2. Information on each page
 3. Information in the subject area
 4. Information related to the subject area
- 4-14. You are listing publications by titles. Following the titles of these publications that are Confidential, you should place what symbol?
1. (C)
 2. (O)
 3. (X)
 4. (*)
- 4-15. What approximate percentage of classified information produced by DON commands is a "derivative classification"?
1. 90%
 2. 70%
 3. 50%
 4. 25%
- 4-16. Derivative classification is most commonly accomplished by what means?
1. Command guidance
 2. Guidance from the original classification authority
 3. CNO directive
- 4-17. Retired and Reserve personnel in an inactive status are NOT entitled to access to classified information merely because of their present or former status.
1. True
 2. False

- 4-18. When a DON command receives a report of compromise and does not have custodial responsibilities for the material, the command must immediately notify which of the following agencies?
1. The command having custodial responsibilities
 2. NCIS field office
 3. Both 1 and 2 above
 4. Secretary of the Navy
- 4-19. What publication should you use to determine the type of investigation required when classified information is subjected to loss or compromise?
1. U.S. Navy Regulations
 2. JAGMAN
 3. MILPERSMAN
 4. Security Manual
- 4-20. To counter the threat of possible compromise of COMSEC, what organization established the NCIRES?
1. DIA
 2. COMNAVSECGRU
 3. NSA
 4. ONI
- 4-21. While on watch after hours, you discover in an unoccupied space an unlocked safe containing classified material. What action should you take?
1. Lock the safe
 2. Notify the person responsible for the safe
 3. Notify the senior duty officer or security manager
 4. Inventory the classified material
- 4-22. What form is used when one command informs another that a security discrepancy has occurred during shipment of classified material?
1. OPNAV Form 5510
 2. OPNAV Form 5511/51
 3. DD Form 398
 4. SF 1492
- 4-23. Which of the following situations might lead to the subversion of personnel in a position to obtain classified material?
1. Excessive alcohol abuse
 2. Illicit personal relationships
 3. Excessive indebtedness
 4. Each of the above
- 4-24. If uncleared personnel enter your workspace, what step(s) should you take to sanitize the area?
1. Cover the classified material
 2. Secure the classified material
 3. Both 1 and 2 above
 4. Post a guard
- 4-25. Which of the below listed individuals is NOT authorized to declassify or downgrade classified information?
1. Secretary of the Navy
 2. Department Head
 3. Chief of Staff
 4. Director of Naval History
- 4-26. What type of information is exempt from a mandatory declassification review?
1. Naval tactics
 2. Information originated by a President
 3. Ship characteristics
 4. Training material

- 4-27. What is the difference, if any, between "clearing" and "declassifying" magnetic media?
1. Clearing is done when the media will remain within the command
 2. Declassifying is done when the media will remain within the command
 3. Cleared data need not be marked or controlled
 4. There is no difference
- 4-28. The procedures used to declassify cryptographic media are the same as for other classified media.
1. True
 2. False
- 4-29. Which of the following levels of protection is used in the IDS?
1. Penetration
 2. Motion
 3. Point
 4. Each of the above
- 4-30. Your command should test its alarm system at least how often?
1. Weekly
 2. Biweekly
 3. Monthly
 4. Yearly
- 4-31. The combination to a safe containing classified information should be changed at what maximum intervals?
1. Monthly
 2. Every six months
 3. Annually
 4. Every two years
- 4-32. What record is used for certifying the security of each vault, secure room, or container used to store classified material?
1. SF 700
 2. FM 258
 3. DD 398
 4. DD 1148
- 4-33. Which of the following is the correct definition of a chart?
1. A chart portrays water areas only
 2. A chart is a map that is used only at sea by navigators
 3. A chart is the background upon which a map is superimposed
 4. A chart is a graphic illustration of one particular area and is especially designed for use in navigation
- 4-34. Three-dimensional air warfare forces use maps to a greater extent than two-dimensional ground forces because of the distances involved and because of air attacks on man-made objects.
1. True
 2. False
- 4-35. A perfect map or chart should have which of the following characteristics?
1. Constant scale
 2. Conformity to the surface of the Earth
 3. Portrayal of great circles as a straight line
 4. Each of the above

- 4-36. Various projections are used in constructing maps. What is the primary purpose of a given map projection?
1. To control distortion
 2. To establish geographic coordinates
 3. To eliminate distortion
 4. To establish a navigation reference
- 4-37. In the construction of a Mercator chart, the surface of the Earth is projected on a
1. plane tangent to the Earth's surface at any point
 2. sphere tangent to the Equator
 3. plane tangent to the poles
 4. cylinder tangent to the Equator
- 4-38. On the Mercator projection, meridians appear as
1. vertical lines that are parallel and equally spaced
 2. parallel lines whose spacing increases as longitude increases
 3. straight lines that intersect at the poles
 4. curved lines that bend toward the point where the projection was made
- 4-39. On a Mercator projection, parallels appear as
1. vertical lines that are parallel and equally spaced
 2. parallel lines whose spacing increases as latitude increases
 3. straight lines that intersect at the poles
 4. curved lines that bend toward the point where the projection is made
- 4-40. Transverse Mercator projections possess which of the following characteristics?
1. The great circle appears as a straight line
 2. All parallels curve concave to the nearest pole
 3. Areas are correctly represented only along the reference meridian
 4. Each of the above
- 4-41. A pilot flying across the United States would most likely navigate with a chart constructed from (a) which projection and (b) why?
1. (a) Mercator (b) because its scale is constant along the Equator
 2. (a) Transverse Mercator (b) because its scale is constant along the reference meridians
 3. (a) Lambert Conformal Conic (b) because it affords maximum accuracy of distance and direction
 4. Mercator, (b) because it affords constant scale along reference meridians
- 4-42. Charts constructed on the Polar Stereographic projection are often used for
1. plotting original surveys
 2. polar navigation
 3. celestial navigation
 4. maneuvering inshore
- 4-43. The Gnomonic projection is particularly helpful in what plotting operations?
1. Great circle routes
 2. Rhumb line routes
 3. Channel courses
 4. Harbor approaches

- | |
|---|
| <ul style="list-style-type: none"> A. Mercator B. Lambert Conformal C. Transverse Mercator D. Polyconic |
|---|

Figure 4A

Figure 4A.-Map projections

IN ANSWERING QUESTIONS 4-44 THROUGH 4-47, REFER TO FIGURE 4A AND SELECT THE MAP PROJECTION THAT IS USED TO CONSTRUCT THE CORRESPONDING CHART.

4-44. Which projection is used for the Tactical Pilotage Chart?

- 1. A
- 2. B
- 3. C
- 4. D

4-45. Which projection is used for the Antisubmarine Warfare Plotting Chart?

- 1. A
- 2. B
- 3. C
- 4. D

4-46. Which projection is used for the Joint Operations Graphic-Air?

- 1. A
- 2. B
- 3. C
- 4. D

4-47. Which projection is used for the Jet Navigation Chart?

- 1. A
- 2. B
- 3. C
- 4. D

4-48. The ratio between map distance and ground distance is called

- 1. contour interval
- 2. map-to-ground variation
- 3. map scale
- 4. map-to-ground deviation

4-49. The representative fraction (RF) is the most used method of expressing what factor on military maps?

- 1. Map scale
- 2. Contour interval
- 3. Map-to-ground variation
- 4. Map-to-ground deviation

4-50. If the RF of a map is 1:50,000, one inch on that map is equal to what ground distance?

- 1. 50,000 meters
- 2. 50,000 feet
- 3. 50,000 centimeters
- 4. 50,000 inches

4-51. An airfield is shown on a map that has a scale of 1:250,000. If a runway on the airfield measures 0.5 inch, what is the approximate ground distance length of the runway?

- 1. 25,000 ft
- 2. 20,800 ft
- 3. 12,500 ft
- 4. 10,400 ft

4-52. What are the different types of graduations used on graphic scales?

- 1. Statute miles
- 2. Nautical miles
- 3. Kilometers
- 4. All of the above

IN ANSWERING QUESTIONS 4-53 THROUGH 4-56, SELECT THE DISTANCE EQUIVALENT OF THE QUANTITY IDENTIFIED IN THE QUESTION.

4-53. One kilometer is equal to

1. 6,080 feet
2. 5,280 feet
3. 1,000 meters
4. 1 meter

4-54. One nautical mile is equal to

1. 6,080 feet
2. 5,280 feet
3. 3,280 feet
4. 1,000 meters

4-55. 39.37 inches is equal to

1. 5,280 feet
2. 6,080 feet
3. 1,000 meters
4. 1 meter

4-56. One statute mile is equal to

1. 5,280 feet
2. 6,080 feet
3. 3,280 feet
4. 1,000 meters

4-57. The common geographic grid employed on maps and charts designates the horizontal lines as latitude and vertical lines as longitude.

1. True
2. False

4-58. Any universal system of determining distance, direction, or location on a map must employ a unique reference point.

1. True
2. False

4-59. The Northern and Southern Hemispheres are divided by a line of longitude.

1. True
2. False

4-60. The latitude of a given point locates that point relative to its distance from the Equator.

1. True
2. False

4-61. "Parallel 19 degrees North" is common terminology for 19 degrees north latitude.

1. True
2. False

4-62. A line of latitude must always be designated as east, west, north, or south with respect to its point of origin.

1. True
2. False

4-63. If the Equator is 0° , what is the numerical value of latitude at either of the poles?

1. 60°
2. 90°
3. 120°
4. 180°

4-64. Which of the following is the correct way to refer to a point on a map that is located two-thirds of the way between 35 and 36 degrees north latitude?

1. $35^\circ 20'$
2. $35^\circ 40'N$
3. $35^\circ 40'$
4. $35^\circ 20'N$

- 4-65. Which of the following geographic coordinates of latitude is written in the correct military notation format?
1. $8^{\circ}30'45''N$
 2. $08^{\circ}30'45''North$
 3. 483045N
 4. 83045N
- 4-66. When the latitude value in military notation is less than 10 degrees, the coordinate designation is indicated by adding a
1. 0 to the right of the degree number so there are two digits
 2. dash to the right of the degree number
 3. dash to the left of the degree number
 4. 0 to the left of the degree number so there are two digits
- 4-67. When military notation is used to express longitude, how many digits are needed in the degrees portion of the coordinate?
1. One
 2. Two
 3. Three
 4. Four
- 4-68. What line divides the Eastern and Western Hemispheres into two equal parts?
1. The Prime Meridian
 2. A line of longitude
 3. The Prime Longitude
 4. A meridian
- 4-69. A person travels from Greenwich, England, until he reaches a meridian designated 90° . In which longitudinal direction may he have traveled?
1. East only
 2. West only
 3. Either east or west
 4. Either north or south
- 4-70. CVN 72 is at anchor at the intersection of 10 degrees, 30 minutes, 7 seconds south and 40 degrees, 5 minutes, 17 seconds west. Which of the following coordinates is the correct military notation of the location?
1. 103007S0400517W
 2. $10^{\circ}30'07''Sand4005'17''W$
 3. $10^{\circ},30',07''S$ & $40^{\circ},5',17''W$
 4. 10307S40517W
- 4-71. A man walking at an azimuth of 45° will be headed in which direction?
1. East
 2. North
 3. Northeast
 4. East-northeast

- A. Be sure that the course line crosses a meridian.
- B. Align a straight edge along the course line.
- C. Connect the points between which the course is to be measured with a straight line.
- D. Place the center hole over the intersection.
- E. Be sure that the protractor segment of the plotter is up.
- F. Measure the course by taking a reading from the correct scale.

Figure 4B

Figure 4B.-Procedures for using the Weems plotter

IN ANSWERING QUESTION 4-72, REFER TO FIGURE 4B.

4-72. In what order should you perform the steps to use the Weems Plotter correctly?

1. D, C, A, B, F, E
2. C, A, D, E, B, F
3. C, B, A, D, E, F
4. B, F, C, D, E, A

4-73. Base north directions, except for true north, are NOT constant on maps representing a portion of the Earth's surface.

1. True
2. False

4-74. The variation between magnetic north and true north is constant and does NOT vary from one point on the Earth to another.

1. True
2. False

4-75. Grid north variation must be computed and compensated for prior to determining grid coordinates from a map.

1. True
2. False

ASSIGNMENT 5

Textbook Assignment: "Mapping, Charting, and Geodesy (continued)," and "Imagery Interpretation"; chapters 5 and 6, pages 5-15 through 6-5.

5-1. At 38° North, approximately what distance is represented by one minute of longitude?

1. One nautical mile
2. Less than one nautical mile
3. More than one nautical mile
4. Two statute miles

- | |
|-------------------|
| A. 100,000 meters |
| B. 10,000 meters |
| C. 1,000 meters |
| D. 100 meters |

Figure 5A

Figure 5A.-Grid sizes.

5-2. To determine distance on a Mercator chart, the midlatitude scale may be used without dividing the course into shorter segments if the north-south distance between origin and destination does NOT exceed what maximum?

1. 200 nautical miles or 3°20'
2. 300 nautical miles or 5°
3. 400 nautical miles or 6°20'
4. 540 nautical miles or 9°

5-3. How should you read UTM coordinates?

1. To the left and up
2. To the left and down
3. To the right and up
4. to the right and down

5-4. Except in the polar areas, what is the size of the basic unit used in the UTM grid system?

1. 6° X 6°
2. 15° quadrangle
3. 6° X 8°
4. 100,000 meter square

IN ANSWERING QUESTIONS 5-5 THROUGH 5-8 SELECT THE CORRECT GRID SIZE IN FIGURE 5A.

5-5. The UTM grid coordinate 2NQQ5345 is equal to

1. A
2. B
3. C
4. D

5-6. The UTM grid coordinate 2NQQ is equal to

1. A
2. B
3. C
4. D

5-7. The UTM grid coordinate 2NQQ54 is equal to

1. A
2. B
3. C
4. D

5-8. The UTM grid coordinate 2NQQ535455 is equal to

1. A
2. B
3. C
4. D

- 5-9. Which of the following grid systems employ(s) the metric system to locate specific points on contact scale photography?
1. UTM
 2. Inch-square
 3. URG
 4. Both 2 and 3 above
- 5-10. What are the inch-square grid coordinates for a point on a 9- x 9-inch photograph if the point is located 1.5 inches from the top and 1.3 inches from the right edge of the photograph?
1. 7.707.5
 2. 7775
 3. 770750
 4. 077075
- 5-11. Which of the following units of measure may be employed with the Thrust-line Reference system?
1. Meters
 2. Inches
 3. Centimeters
 4. Each of the above
- 5-12. The GEOREF system is based on
1. latitude and longitude values
 2. the metric system
 3. the Arabic system
 4. unique alphanumeric system
- 5-13. The GEOREF system divides the Earth into 288 basic 15° quadrangles that are lettered in which of the following ways?
1. East to west, north to south
 2. East to west, south to north
 3. West to east, north to south
 4. West to east, south to north
- 5-14. Refer to figure 5-18 in your training manual. The Florida peninsula and the island of Cuba are both in the same 15° grid square. Which of the following letter combinations correctly identifies the southwest corner of that grid square?
1. BH
 2. EH
 3. FH
 4. GH
- 5-15. The GEOREF grid coordinate WGBN3648 locates a point to what maximum degree of accuracy?
1. One meter
 2. One nautical mile
 3. Ten meters
 4. One statute mile
- 5-16. The information necessary to interpret a map is located in the area of the map sheet that borders the representation of the Earth's surface. What is this information commonly called?
1. The legend
 2. Marginal information
 3. Information key
 4. Guide book

5-17. As a general rule, symbols are printed on the map in how many different colors?

1. One
2. Two
3. Three
4. Four

5-18. Which of the following information is NOT normally contained in the marginal areas of aeronautical and nautical charts?

1. Sheets, series, and edition numbers that apply to the particular sheet
2. Source information and reliability
3. An adjoining chart diagram which identifies all sources and scales of adjoining charts
4. Date of information

5-19. Which of the following marginal data provides translation information for the foreign language terminology used to identify features or objects on some maps?

1. Source information
2. Glossary
3. Translation guide
4. Reliability index

5-20. Scaled down representations on maps and charts of objects on the Earth's surface are referred to as

1. signs
2. symbols
3. depictions
4. object representations

5-21. As a general rule, black is used on a map to portray which of the following features?

1. Elevations
2. Aeronautical information
3. Man-made or cultural features
4. Cities or radar significant structures

5-22. Which of the following information is NOT normally found on topographic maps?

1. Vegetation classification
2. Road classification
3. Survey reference points
4. Radar significant data

5-23. Data dealing with ocean currents and symbols indicating the conditions of the ocean bottom is provided on which of the following maps or charts?

1. Aeronautical charts
2. Topographic maps
3. Nautical charts
4. Each of the above

- | |
|---------------------|
| A. Contour interval |
| B. Form lines |
| C. Hachures |
| D. Hill shading |
| E. Layer tints |
| F. Spot elevation |

Figure 5B

Figure 5B.-Terrain identification

IN ANSWERING QUESTIONS 5-24 THROUGH 5-28, REFER TO FIGURE 5B FOR THE CORRECT METHODS OF INDICATING TERRAIN SHAPE AND/OR ELEVATION ON MAPS.

5-24. Which method is used to indicate isolated or abrupt changes in landform elevation or depression?

1. B
2. C
3. D
4. E

5-25. Which method is often used, in conjunction with other relief portrayal methods, to indicate precise elevations?

1. C
2. D
3. E
4. F

5-26. Which method is used to show the exact gradient and slope of a hill?

1. A
2. B
3. E
4. F

5-27. Which method is used to portray generally possible landform relief in the absence of more accurate data?

1. A
2. B
3. C
4. F

5-28. Which method indicates elevations through the use of bands of equal elevation range?

1. B
2. C
3. D
4. E

5-29. How many degrees does a time zone extend on either side of each standard time meridian?

1. $7\frac{1}{2}^{\circ}$
2. 15°
3. 24°
4. 30°

5-30. Which of the following relations holds true in time zones that are west of Greenwich?

1. The Zone Description (ZD) is plus and is added to GMT to get zone time
2. The ZD is plus and is added to zone time to get GMT
3. The ZD is minus and is added to GMT to get zone time
4. The ZD is minus and is added to zone time to get GMT

5-31. What correction must be applied to GMT to compute zone time at 158° W latitude?

1. Plus 10 hr
2. Minus 10 hr
3. Plus 11 hr
4. Minus 11 hr

A.	TPC
B.	JNC
C.	ONC
D.	1501 JOG-AIR

Figure 5C

Figure 5C.-Chart titles.

IN ANSWERING QUESTIONS 5-32 THROUGH 5-35, SELECT FROM FIGURE 5C THE ABBREVIATED CHART TITLE WHICH FITS THE DESCRIPTION GIVEN.

5-32. This chart is designed for preflight planning and enroute navigation; used for operational planning and has a scale of 1:1,000,000.

1. A
2. B
3. C
4. D

5-33. This chart is designed for low-level, detailed preflight planning and mission analysis, and has a scale of 1:500,000.

1. A
2. B
3. C
4. D

5-34. This chart is designed for joint tactical air operations, intelligence briefings, and has a scale of 1:250,000.

1. A
2. B
3. C
4. D

5-35. This chart is designed for high-altitude, computer-assisted radar navigation/bombing by strategic aircraft and has a scale of 1:2,000,000.

1. A
2. B
3. C
4. D

5-36. Which of the following statements is/are correct concerning overlays?

1. The overlay can be used with a map or photograph
2. An overlay presents the information pictorially
3. The overlay must be marked so as to allow accurate positioning of a base map
4. All of the above

5-37. Which of the following types of overlays presents information on the location and disposition of friendly forces?

1. Strategic
2. Tactical
3. Operational
4. Intelligence

5-38. Which of the following publications contains information concerning the construction and use of military symbols?

1. FM 20-31
2. FM 21-30
3. FM 30-21
4. FM 31-20

5-39. Which of the following elements may be used in the construction of a military symbol?

1. Color
2. Diagram
3. Abbreviation
4. Each of the above

- 5-40. What type of information is identified by military symbols used on overlays?
1. The maximum amount of information
 2. The most essential information
 3. The enemy's location only
 4. The enemy's unit size only
- 5-41. What is the basic unit used in the construction of military symbols?
1. Square
 2. Circle
 3. Triangle
 4. Rectangle
- 5-42. What color should be used to construct a military symbol indicating the position of an enemy, man-made obstacle?
1. Red
 2. Blue
 3. Green
 4. Yellow
- 5-43. If colors are not used on an overlay, the location of friendly forces is indicated by symbols which are outlined with a
1. double solid line
 2. single solid line
 3. double broken line
 4. single broken line
- 5-44. Which of the following is the most common material used to construct overlays?
1. Tracing paper
 2. Clear acetate
 3. Frosted acetate
 4. Any opaque material
- 5-45. Rub-Off letters may be procured in a wide variety of military symbols as well as letters and numbers.
1. True
 2. False
- 5-46. Photographic overlays are generally used to portray friendly situations.
1. True
 2. False
- 5-47. In some cases, an enemy situation overlay may be constructed on a photographic base in preference to a map base.
1. True
 2. False
- 5-48. Which of the following publications is the main source of information on the availability and currency of NIMA products?
1. Notice to Mariners
 2. NIMA Bulletin
 3. NIMA Aeronautical Chart Updating Manual
 4. NIMA Bulletin Digest
- 5-49. What form is used for AUTODIN/MILSTIP requisitions?
1. DD Form 173
 2. DD Form 1350
 3. DD Form 1149
 4. SF Form 344
- 5-50. What form is used for ordering items NOT identified in the NIMA Catalog?
1. DD Form 173
 2. DD Form 1350
 3. DD Form 1149
 4. SF Form 344

- 5-51. How should charts be stowed?
1. Flat only
 2. Flat or folded only
 3. Folded only
 4. Flat, folded, or rolled
- 5-52. For inventory purposes, how should the chart allowance be listed?
1. High and low quantity
 2. High quantity only
 3. Low quantity only
 4. According to series
- 5-53. Which of the following types of intelligence briefing charts does NOT require professionally and formally prepared graphics?
1. Tactical
 2. Orientation
 3. Strategic
 4. Welcome aboard
- 5-54. Which of the following is NOT a component of mounting maps and charts?
1. Identify the surface
 2. Declassify the surface
 3. Prepare the surface
 4. Collect materials
- 5-55. The type of annotations used depends on what factor?
1. Classification
 2. Availability of material
 3. Size and type of information
 4. Your branch of service
- 5-56. Which of the following terms best describes the image interpreter?
1. Investigator
 2. Photographer
 3. Writer
 4. Recorder
- 5-57. Identification of objects on aerial photography and deduction of their significance, collated with visual reconnaissance of the area and reports from all known sources, is called
1. imagery interpretation
 2. an intelligence estimate
 3. imagery intelligence
 4. the intelligence situation
- 5-58. Aerial imagery has a number of advantages over other sources of information. What is one of its disadvantages?
1. The interpreter, unlike the ground observer, is far removed from the scene
 2. It provides a permanent record
 3. It does not change
 4. Often, finer details of a target are hard to discern
- 5-59. Image interpretation does not always provide the information that is required. A good interpreter will compare his findings and supplement them with which of the following references?
1. Maps and charts
 2. Intelligence information reports
 3. Newspaper articles
 4. Each of the above
- 5-60. Which, if any, of the following functions best describes the IS as an imagery interpreter?
1. A mapmaker
 2. A bridge between the sources and the consumer
 3. A report writer
 4. None of the above

5-61. The task of imagery interpretation requires personnel whose background and experience represent ability in

1. engineering
2. athletics
3. many fields
4. mathematics

5-62. Before the imagery interpreter can produce usable intelligence from available imagery, he must first have a complete understanding of

1. significant intelligence information
2. order of battle information
3. collection procedures
4. enemy tactics

5-63. To better understand the enemy, the IS should study which of the following capabilities of the enemy?

1. Industrial potential
2. Transportation facilities
3. Economic situation
4. Each of the above

- | | |
|----|---------|
| A. | Shape |
| B. | Pattern |
| C. | Texture |
| D. | Size |
| E. | Shadow |
| F. | Tone |

Figure 5D

Figure 5D.-Photo image characteristics.

IN QUESTIONS 5-64 THROUGH 5-69, SELECT FROM FIGURE 5D THE PHOTO CHARACTERISTIC DESCRIBED.

5-64. Which characteristic affects the identification of object dimensions from photography?

1. C
2. D
3. E
4. F

5-65. What characteristic is used in the determination of beach trafficability?

1. A
2. B
3. C
4. D

5-66. What characteristic is related to the regularity or irregularity of an object form on a photograph?

1. A
2. B
3. D
4. F

5-67. Which characteristic may be used in the delineation of agricultural land use?

1. B
2. C
3. E
4. F

5-68. Which characteristic may be instrumental in determining the shape of vertical objects?

1. B
2. C
3. E
4. F

- 5-69. Variations in which characteristic are mandatory to object discernibility?
1. B
 2. c
 3. E
 4. F
- 5-70. In which of the following ways are man-made features depicted on vertical photography?
1. By straight lines and controlled curves
 2. By irregular lines
 3. By wavy lines and controlled curves
 4. By meandering lines
- 5-71. The spatial arrangement of objects refers to which of the following imagery characteristics?
1. Shape
 2. Size
 3. Pattern
 4. Texture
- 5-72. Which, if any, of the following characteristics depend on the reflecting power of the surface?
1. Texture
 2. Tone
 3. Shadow
 4. None of the above
- 5-73. Two or more photos of a given area taken at different times are called
1. multiple imagery
 2. comparative imagery
 3. duplicate imagery
 4. non-comparative imagery
- 5-74. Stereoscope is used in image interpretation to accomplish which of the following functions?
1. Determine object height
 2. Estimate terrain slope
 3. Identify objects
 4. Each of the above
- 5-75. Which of the following normal eye functions is affected by a stereoscope, thereby permitting three-dimensional viewing of photography?
1. Accommodation
 2. Convergence
 3. Fusion
 4. Focus

ASSIGNMENT 6

Textbook Assignment: "Imagery Interpretation (continued)"; chapter 6, pages 6-6 through 6-24.

- 6-1. Which of the following conditions is NOT a requirement for a satisfactory photo object stereo presentation?
1. The object must have remained stationary between exposures
 2. The two photos must be properly aligned along the line of flight
 3. The photo scale must have remained constant between exposures
 4. The parallax images must be located within 2.5 inches of the photo principal point
- 6-2. The apparent shift of an object from one position to another as it is viewed first by one eye and then the other is termed
1. fusion
 2. accommodation
 3. parallax
 4. convergence
- 6-3. Photographic parallax may be increased by which of the following actions?
1. Increasing the distance between successive exposures
 2. Selecting every third exposure from a reconnaissance strip
 3. Decreasing the distance between successive exposures
 4. Selecting parallax images that are further apart on the photographs
- 6-4. If, at the time of exposure, an object is moving on the ground in the same direction as the reconnaissance aircraft, what is the effect, if any, on parallax with respect to that object?
1. Increases
 2. Decreases
 3. Either increases or decreases, depending on the speed of the object
 4. None
- 6-5. Extremely tall objects photographed from a low altitude will normally result in which of the following stereo effects?
1. False parallax
 2. Exaggerated parallax
 3. Double image
 4. Decreased parallax
- 6-6. Inverted stereo is caused by which of the following conditions?
1. Overlapping the left photo on the right photo
 2. Aligning the two photographs across the line of flight
 3. Overlapping the right photo on the left photo
 4. Reversing the order of the two photographs, right for left and left for right

6-7. Which of the following procedures best describes the proper method for performing a cursory search?

1. Study each frame in detail
2. Rapidly scan the film, eliminating unpromising areas
3. Study every third frame in detail
4. Scan every third frame

6-8. Determining the difference between natural and man-made objects on a photograph is a complicated, lengthy process.

1. True
2. False

6-9. The process of imagery interpretation involves a logical area evaluation as well as object identification.

1. True
2. False

6-10. Bringing together the important characteristics of an unknown object and then eliminating the things that the object can not be until the object is identified is the process known as convergence of evidence.

1. True
2. False

6-11. The proper reporting of imagery-derived intelligence serves the single purpose of providing users the information they require.

1. True
2. False

- | |
|----------------------|
| A. Lens and aperture |
| B. Shutter |
| C. Screen |
| D. Dark box |

Figure 6A

Figure 6A.-Camera parts.

IN ANSWERING QUESTIONS 6-12 THROUGH 6-15, SELECT THE CAMERA PART IN FIGURE 6A WHICH CORRESPONDS TO THE DESCRIPTION GIVEN.

6-12. Which part of the camera receives the image?

1. A
2. B
3. C
4. D

6-13. Which camera part is used to exclude all unwanted light?

1. A
2. B
3. C
4. D

6-14. Which part is used to admit light rays?

1. A
2. B
3. C
4. D

6-15. Which camera part is used to control the time allowed for the admittance of light?

1. A
2. B
3. C
4. D

6-16. A lens accomplishes which of the following functions?

1. Controls the image size
2. Improves image sharpness
3. Increases image brightness
4. All of the above

- 6-17. When a lens is focused on an object at infinity, the distance from the focal plane to the optical center of the lens is known as
1. depth of field
 2. depth of focus
 3. focal length
 4. hyperfocal length
- 6-18. The effective aperture (f/number) of a lens is computed by
1. dividing the lens diameter by its focal length
 2. dividing the lens focal length by its diameter
 3. multiplying the lens diameter by its focal length
 4. multiplying the lens focal length by its diameter
- 6-19. What is the relative speed of a lens having a focal length of 12 inches and a diaphragm diameter of 3 inches?
1. f/4
 2. f/5.6
 3. f/15
 4. f/16
- 6-20. If you assume that the lens is focused at infinity, what is the effect on the amount of light transmitted when you change the diaphragm opening from f/4 to f/5.6?
1. Increased by 1/2
 2. Reduced by 1/2
 3. Increased by 1/4
 4. Reduced by 1/4
- 6-21. A between-the-lens shutter is normally positioned as close as practical to the camera diaphragm.
1. True
 2. False
- 6-22. A focal plane shutter should be used to obtain photography when image motion is of critical importance.
1. True
 2. False
- 6-23. A focal plane shutter employs the same mechanical means of controlling light as does a between-the-lens shutter.
1. True
 2. False
- 6-24. If the altitude remains constant, the focal length of a camera determines which of the following conditions?
1. Exposure
 2. Shutter speed
 3. Size of the film
 4. Size of the image
- 6-25. Filters are used to regulate which of the following properties of light?
1. Speed
 2. Intensity
 3. Color
 4. Either 2 or 3 above, depending on type
- 6-26. Filters are employed in aerial photography to reduce haze effect by preventing or reducing the passage of which of the following light rays?
1. Red
 2. Blue
 3. Violet
 4. Ultraviolet

- 6-27. Which of the following filter/film combinations will produce the best haze penetration results?
1. Blue/black-and-white
 2. Dark yellow/color
 3. Red/infrared
 4. Infrared/infrared
- 6-28. Film is composed of a tough, transparent base coated with an emulsion which is sensitive to light. This emulsion is composed of
1. acetate containing metallic silver
 2. gelatin containing silver halide particles
 3. cellulose particles
 4. metallic silver on gelatin
- 6-29. The number of silver particles affected by a photographic developer is dependent upon which of the following characteristics of the light that strikes the emulsion?
1. Intensity
 2. Duration
 3. Both 1 and 2 above
 4. Wavelength
- 6-30. A dye must be added to the film emulsion during manufacture to produce sensitivity to which of the following colors?
1. Red
 2. Blue
 3. Violet
 4. Ultraviolet
- 6-31. The sensitivity of film emulsion to light is referred to in terms of speed.
1. True
 2. False
- 6-32. Density refers to the amount of light required to produce a satisfactory image on a film emulsion.
1. True
 2. False
- 6-33. A dark area of a photographed subject will result in a highlight in the negative.
1. True
 2. False
- 6-34. The range of brightness of the subject between thin and heavy densities in a photographic negative is called halftones.
1. True
 2. False
- 6-35. Prints that are most suitable for interpretation purposes have which of the following levels of contrast?
1. Low
 2. Normal
 3. High
 4. Variable
- 6-36. A high contrast film is most suitable for which of the following purposes?
1. Portraiture
 2. Detailed reconnaissance
 3. Copying line drawings
 4. Copying mosaics
- 6-37. Which of the following terms is used to indicate the capability of a given film emulsion to record a range of brightness values?
1. Density
 2. Contrast
 3. Latitude
 4. Resolution

6-38. Which of the following film emulsion characteristics indicates the degree of detail that the emulsion can reproduce?

1. Density
2. Latitude
3. Contrast
4. Resolving power

6-39. Which of the following is NOT a soft-copy imagery interpretation system?

1. MIIS
2. JDISS
3. NIEWS
4. DIWSA

A.	JDISS
B.	IDEX II
C.	MATRIX
D.	NIEWS
E.	PIES
F.	DIWSA

Figure 6B

Figure 6B.—Soft copy imagery systems.

IN ANSWERING QUESTIONS 6-40 THROUGH 6-45, SELECT THE SOFT COPY SYSTEM FROM FIGURE 6B WHICH CORRESPONDS TO THE DESCRIPTION GIVEN.

6-40. This is low cost software used to produce soft copy imagery.

1. B
2. C
3. D
4. E

5-41. This system provides selective expansion of imagery from magnetic media (VLDS cassettes, 8mm tapes, etc.).

1. A
2. B
3. C
4. D

6-42. This system allows for the registration of Recce images to the Point Position Data Base reference images.

1. F
2. D
3. E
4. C

6-43. This system is a shipboard-deployable photographic editing system.

1. C
2. D
3. E
4. F

6-44. This system, along with MATRIX, is the mainstay of major shore imagery centers.

1. A
2. B
3. C
4. D

6-45. This system supports forces in-garrison and deployed in peacetime, crises, and wartime.

1. A
2. B
3. C
4. D

- 6-46. Digital imagery produced by the various soft-copy systems is usually stored in the
1. 5D system
 2. SCI tape library
 3. CIC
 4. MATRIX
- 6-47. Retrieval of hard or soft-copy imagery is usually dependent on what factor(s)?
1. Availability
 2. Usability
 3. Command procedures
 4. Each of the above
- 6-48. How are hard-copy prints usually stored and cataloged?
1. BE number
 2. Area
 3. Both 1 and 2 above
 4. Originator
- 6-49. What type of photographic scale is best suited for a detailed view of a radar mast?
1. Large
 2. Small
 3. Intermediate
 4. Normal
- 6-50. Which of the following photographic rigging patterns is also referred to as the "standard rig"?
1. Four-point
 2. Six-point
 3. Seven-point
 4. Eight-point
- 6-51. Which of the following publications provides specific requirements for the collections of imagery?
1. DIAM 58-13
 2. FICM
 3. MCM 3-1
 4. FIGSP
- 6-52. Which of the following methods of collection is best suited for an "Incident at Sea"?
1. Motion picture
 2. Video
 3. Either 1 or 2, depending on equipment availability
 4. Helicopter
- 6-53. Which of the following is a principal use of aerial photography for the Navy?
1. Weather analysis
 2. Aircraft identification
 3. Information gathering on an enemy
 4. Weapons targeting
- 6-54. Which of the following is a limitation of aerial photography?
1. Weather
 2. Light conditions
 3. Enemy opposition
 4. Each of the above
- 6-55. The aerial camera consists of a light-free box that supports which of the following elements?
- 1- The lens
 2. The shutter
 3. The diaphragm
 4. Each of the above
- 6-56. The various types of aerial cameras get their names from which of the following characteristics?
1. The way the film passes through the system
 2. Their film size
 3. How they are processed
 4. Each of the above

- 6-57. The framing camera derives its name from
1. its size
 2. the film it uses
 3. the black border masking around the exposure
 4. the continuous way the film passes through the camera

- 6-58. Which of the following types of cameras is known as a panoramic camera?

1. Strip
2. Framing
3. Special format
4. Hand-held

- | |
|-------------------|
| A. Strip |
| B. Framing |
| C. Special format |

Figure 6C

Figure 6C.—Camera types.

IN ANSWERING QUESTIONS 6-59 THROUGH 6-62, REFER TO FIGURE 6C.

- 6-59. Which camera must recycle film between exposures?
1. A
 2. B
 3. C
- 6-60. Film for this type of camera passes continuously in the same direction as the flight of the aircraft.
1. A
 2. B
 3. C
- 6-61. Which camera type accomplishes exceptionally wide coverage?
1. A
 2. B
 3. C

- 6-62. This camera type uses a scanning principle that incorporates a rotating lens.

1. A
2. B
3. C

- 6-63. A photographic mission is flown to obtain information on enemy defensive positions. What is this mission called?

1. A mapping mission
2. A general purpose mission
3. A combat intelligence mission
4. A reconnaissance mission

- 6-64. What photographic mission is flown over exact, preplotted flight lines?

1. A mapping mission
2. A general purpose mission
3. A combat intelligence mission
4. A reconnaissance mission

- 6-65. How many basic rigging patterns are used for maritime surveillance photography?

1. One
2. Two
3. Three
4. Four

- 6-66. How many views are normally required when enemy or potential enemy vessels are photographed?

1. Six
2. Seven
3. Eight
4. Nine

- 6-67. Under normal conditions, how many photographs should be obtained of a merchant vessel encountered at sea?
1. Two
 2. Three
 3. Six
 4. Eight
- 6-68. Radarscope imagery is recorded by an electro-optical sensor, as opposed to a conventional optical camera system.
1. True
 2. False
- 6-69. Radarscope photographic reconnaissance provides information to assist all-weather operations.
1. True
 2. False
- 6-70. One advantage of radarscope photography is that it may be used for camouflage prevention.
1. True
 2. False
- 6-71. Advantages of radarscope photography are that the system has good resolution, and EA can't be directed against it.
1. True
 2. False
- 6-72. Which type of photographic system uses a detector and cooler?
1. Infrared
 2. Radarscope
 3. Forward-looking infrared
 4. Side-looking airborne radar
- 6-73. Infrared sensors can only be used during daylight hours.
1. True
 2. False
- 6-74. Forward-looking infrared (FLIR) systems provide real-time tactical readout capability for aircrews.
1. True
 2. False
- 6-75. The FLIR system is a non-passive, all-weather system used primarily for mapping.
1. True
 2. False

ASSIGNMENT 7

Textbook Assignment: "Imagery Interpretation (continued)"; chapter 6, pages 6-25 through 6-46.

7-1. Laser sensors used aboard reconnaissance aircraft are light recording cameras.

1. True
2. False

7-2. What is the basic difference, if any, between night and day aerial reconnaissance photography?

1. The type of film used
2. The type of shutters used
3. The use of artificial illumination
4. None

7-3. There are how many different types of night photography?

1. One
2. Two
3. Three
4. Four

- | |
|-------|
| A. KA |
| B. KC |
| C. KE |
| D. KS |

Figure 7A

Figure 7A.-Letter designations.

IN ANSWERING QUESTIONS 7-4 THROUGH 7-7, REFER TO FIGURE 7A.

7-4. Which designation corresponds to an airborne reconnaissance camera?

1. A
2. B
3. C
4. D

7-5. Which designation corresponds to an airborne camera designed for mapping purposes?

1. A
2. B
3. C
4. D

7-6. Which designation refers to an airborne camera system?

1. A
2. B
3. C
4. D

7-7. Which of the following designations refers to a still-picture aerial reconnaissance camera?

1. A
2. B
3. C
4. D

7-8. The TARPS pod is attached to a specially configured F-14 called the

1. Crazy Joe
2. Peeping Tom
3. Perkin-Elmer
4. Mohawk

- 7-9. The TARPS pod is non-jettisonable and is attached directly to the starboard-underside at which weapons station?
1. Number 1
 2. Number 2
 3. Number 5
 4. Number 6
- 7-10. What is the designation of the infrared line scan (IRLS) system employed by the TARPS aircraft?
1. AN/ALQ-61
 2. AN/ms-21
 3. AN/AAD-5
 4. AN/APD-7
- 7-11. What is the primary mission of the S-3A Viking aircraft?
1. Patrol
 2. Reconnaissance
 3. Antisubmarine warfare
 4. Shipping surveillance
- 7-12. What is the secondary mission of the P3C Orion aircraft?
1. Patrol
 2. Surface surveillance
 3. Antisubmarine warfare
 4. Strike warfare
- 7-13. Which of the following camera systems is used onboard the P3C aircraft?
1. 35mm hand-held
 2. Agiflite 70mm
 3. Still video
 4. Each of the above
- 7-14. Which of the following aircraft is slated as the host platform for the ATARS?
1. F-14 TOMCAT
 2. F/A-18 HORNET
 3. F-5 TIGERSHARK
 4. EA-6B PROWLER
- 7-15. ATARS is designed to supply digital imagery to which of the following systems?
1. JSIPS
 2. MIIS
 3. DIWSA
 4. IDEX II
- 7-16. Which of the following publications contains information on the titling, plotting, and forwarding of aerial imagery?
1. DIAM 55-5
 2. DIAM 55-7
 3. DIAM 58-1
 4. DIAM 58-2
- 7-17. Photographic titling information is printed on what part of the film?
1. Along the running edge on the base side
 2. On the emulsion side along the trailing edge
 3. Along the running edge on either the base or emulsion side
 4. On either the base or emulsion side along the trailing edge
- 7-18. In what manner is photographic titling information shown on aerial photography?
1. In upper and lower case letters and numerals, normally restricted to two lines
 2. In upper case letters and numerals, normally restricted to two lines unless operating under a waiver
 3. In upper case letters and numerals, restricted to three lines
 4. In upper and lower case letters and numerals, restricted to three lines

- 7-19. What should be the minimum length of the leader and trailer on each roll of aerial film?
1. 15 ft
 2. 5 to 7 ft
 3. 8 ft
 4. 10 ft
- 7-20. Which of the following materials should NOT be used to apply titling information to the leader and trailer of a roll of aerial film?
1. Grease pencil
 2. Markers containing permanent ink
 3. Standard India ink
- 7-21. Which of the following is NOT a valid consideration when your chain of command considers an imagery request?
1. Your theater request is the most important
 2. Awareness of what their platforms are being tasked against
 3. Ability to track each asset
 4. Ensuring that each request is justified
- 7-22. When requesting imagery from an F-14 TARPS squadron, you should consult which of the following publications?
1. NWP 3-55.10
 2. DIAM 58-5
 3. FICM
 4. NWP 3-55.11
- 7-23. Under normal conditions, what camera is recommended for collection of terrestrial intelligence photography?
1. 35mm
 2. 16mm
 3. Single-lens reflex
 4. Stereo
- 7-24. Details not normally obtained from aerial views is an advantage of periscope photography.
1. True
 2. False
- 7-25. Combat periscope photography is ONLY of value after an attack.
1. True
 2. False
- 7-26. Which of the following publications is an excellent unclassified reference of naval ships?
1. DIM 57-7, Vol 14
 2. DIA Fact Book
 3. Jane's Fighting Ships
 4. FIGSP
- 7-27. What is the most prominent recognition feature of an aircraft carrier's flight deck?
1. Size
 2. Superstructure
 3. Catapults
 4. Configuration
- 7-28. Helicopter carriers resemble, but are smaller than, conventional aircraft carriers. What is another distinctive feature of helo carriers?
1. The lack of arresting gear and catapults
 2. The location of the island
 3. The reduced amount of armament
 4. The lack of aircraft elevators

- 7-29. A cruiser generally operates with which of the following forces?
1. ASW
 2. Amphibious
 3. Strike
 4. Each of the above
- 7-30. What is the primary mission of the CG in a battle group?
1. ASW
 2. A S W
 3. AAWC
 4. OTHC
- 7-31. Destroyers are configured to perform which of the following missions?
1. ASW
 2. AAW
 3. ASUW
 4. Each of the above
- 7-32. Which of the following features should help you distinguish a frigate from a corvette?
1. The presence of a helo pad aft
 2. Their markedly heavier armament
 3. Their notably lighter armament
 4. A smaller superstructure
- 7-33. What is the maximum number of helicopter landing pads usually found on a large amphibious ship?
1. Eight
 2. Seven
 3. Six
 4. Four
- 7-34. Where is the superstructure usually located on medium and small amphibious ships?
1. Forward
 2. Center
 3. Just aft of center
 4. Aft
- 7-35. Which of the following factors is common to most auxiliary ships?
1. They are generally the same size
 2. They are lightly armed
 3. They are heavily armed
 4. They are similarly configured
- 7-36. Which of the following classes of AGIs was constructed from the keel up to perform intelligence collection?
1. OKEAN
 2. PRIMORYE
 3. MIRNYY
 4. DNEPR
- 7-37. What is the predominant recognition feature of AGIs?
1. Their similarity to fishing trawlers
 2. The absence of weapons systems
 3. A large quantity of electronic equipment
 4. A very large superstructure
- 7-38. Which of the following classes of submarines are you most likely to see surfaced?
1. FOXTROT
 2. VICTOR
 3. CHARLIE
 4. YANKEE
- 7-39. What portion of a submarine is usually underwater when the submarine is surfaced?
1. One-third
 2. One-half
 3. Two-thirds

- 7-40. What are the holes that permit seawater to enter the superstructure when a conventional submarine is diving?
1. Limber
 2. Exhaust
 3. Tank
 4. Water
- 7-41. Where are the control planes located on most modern submarines?
1. Bow section
 2. Stern section
 3. On the sail
 4. Forward of the sail
- 7-42. Why do many modern submarines have sail planes?
1. Speed diving
 2. Electronic housings
 3. Depth stability
 4. Hull integrity
- 7-43. What appearance group largely constitutes SSBNs?
1. 1
 2. 2
 3. 3
 4. 4
- 7-44. Experimental prototypes and conversion submarines usually are coded in which of the following groups?
1. 8
 2. 7
 3. 6
 4. 4
- 7-45. What submarine type is built for speed and maneuverability and used in fast attack roles?
1. SSAG
 2. SSB
 3. SSG
 4. SS
- 7-46. Which of the following submarines maintains a patrol from which its missiles can reach enemy industrial complexes?
1. YANKEE
 2. DELTA
 3. TYPHOON
 4. Each of the above
- 7-47. What type of submarine often is used to shadow a carrier battle group?
1. SSBN
 2. SSGN
 3. SSB
 4. SSA
- 7-48. Why is it important to closely monitor arms carriers?
1. Because they make excellent targets for hijackers
 2. To better understand political ties and keep abreast of OOB
 3. To keep track of their location in the event of war
 4. Because they are merchant ships
- 7-49. CIS naval forces frequently replenish from CIS merchant ships.
1. True
 2. False
- 7-50. Both political and naval intelligence can be derived from the study of merchant ships.
1. True
 2. False

- 7-51. AOB information is of vital importance only in time of war.
1. True
 2. False
- 7-52. Fighter aircraft are readily identified on good quality imagery.
1. True
 2. False
- 7-53. Single-engine jets can be distinguished from single-engine propeller aircraft by studying their wings.
1. True
 2. False
- 7-54. Multi-engined jet aircraft CANNOT be distinguished from multi-engined propeller aircraft.
1. True
 2. False
- 7-55. General appearance of aircraft may often be so similar that the only difference is
1. fuselage shape
 2. tail length
 3. wingspan
 4. engine type
- 7-56. What lighting conditions, if any, are necessary to see the shadow of the transparent nose of an aircraft?
1. Rear lighting
 2. Overhead lighting
 3. Front lighting
 4. None
- 7-57. What is a popular system used for identifying aircraft?
1. DEFT
 2. WEFT
 3. AIS
 4. NEFT
- 7-58. What part(s) of an aircraft is/are used as the main identification feature(s) on vertical imagery?
1. Nose
 2. Fuselage
 3. Wings
 4. Tail
- 7-59. For identification purposes, which of the following shapes is assigned to the fuselage of an aircraft?
1. Tube
 2. Rounded
 3. Blunt
 4. Pointed
- 7-60. What phenomenon sometimes occurs on vertical imagery when an aircraft is observed in side light?
1. The wings are not visible
 2. The wing nearest the light is invisible
 3. The wing farthest from the light is invisible
 4. The entire aircraft is invisible
- 7-61. What effect does halation have on the appearance of an aircraft on aerial imagery?
1. It appears smaller
 2. It appears darker
 3. It appears shorter
 4. It appears larger

- 7-62. What are the main recognition features of helicopters?
1. Wing, fuselage, and tail boom
 2. Cockpit and fuselage
 3. Fuselage and rotor system
 4. Rotor system and main rotor blades
- 7-63. How many rotor systems are used on CIS helicopters?
1. Two
 2. Three
 3. Four
 4. Five
- 7-64. NATO uses code names to distinguish between CIS jet and propeller bomber aircraft. In what way do the code names indicate the bomber types?
1. By using the number of syllables in the name
 2. By using different animal names
 3. By using different initial letters
 4. By appending different suffix letters
- 7-65. What clue can help identify a missile that is in a container or otherwise covered?
1. The number of fins
 2. The configuration of the container
 3. The color of the container or shroud
 4. The length and diameter of the container or shroud
- 7-66. What is the designation of a missile with a range of 2,800 miles?
1. ICBM
 2. IRBM
 3. MRBM
 4. SRBM
- 7-67. A complete description of a missile system should include which of the following items of information?
1. All of the missile's classifications
 2. The missile type
 3. Whether or not it is a strategic or tactical system
 4. Each of the above
- 7-68. What is the classification of a submarine-launched ballistic missile?
1. Strategic
 2. Tactical
 3. SAM
 4. SLSM
- 7-69. Which of the following missile systems is/are used to support the on-scene commander?
1. ICBM
 2. ABM
 3. ASM
 4. All of the above
- 7-70. What term applies to an SSM that follows an unguided trajectory?
1. Rocket
 2. Projectile
 3. Cruise
 4. Uncontrolled SSM

- 7-71. How does a MIRV enhance the performance of a missile?
1. By increasing the speed of the missile
 2. By allowing better control
 3. By permitting a higher trajectory
 4. By enabling one missile to cover more than one target
- 7-72. What is the purpose of using more than one stage on a missile?
1. To enhance control
 2. To increase range
 3. To improve payload handing capability
 4. To lower trajectory
- 7-73. What is the advantage of using a TEL rather than a permanent site for a missile system?
1. A permanent site has no mobility
 2. A TEL is more difficult to detect
 3. A TEL is easier to service
 4. A TEL is impossible to detect on imagery
- 7-74. What is the purpose of wings on a cruise missile?
1. To increase speed
 2. To decrease speed
 3. To simulate an airplane
 4. To alter course and altitude
- 7-75. What recognition features make permanent SAM sites easy to detect on imagery?
1. The site configuration and the presence of radar
 2. The large size of missiles and lack of radar
 3. The site location and the support vehicles
 4. The missile revetments and the lack of radar

ASSIGNMENT 8

Textbook Assignment: "Imagery Interpretation (continued)," and "Mensuration Techniques"; chapters 6 and 7, pages 6-46 through 7-10.

- 8-1. Which of the following CIS SAM systems is shoulder-fired?
1. SA-6
 2. SA-2
 3. SA-3
 4. SA-14
- 8-2. Why is it inadvisable to attempt to identify a SAM system by its configuration alone?
1. All SAM sites are configured differently
 2. All SAM sites are configured similarly
 3. Some SAM sites can accommodate several different SAM systems
 4. The number and placement of radar systems is always the same at all sites
- 8-3. Which of the following information can aid in the identification of antitank missile systems of a specific country?
1. The knowledge of OOB
 2. The knowledge of specific configurations of systems
 3. The familiarity with deployment methods
 4. Each of the above
- 8-4. On which of the following platforms are AAMs generally deployed?
1. Fighter aircraft
 2. Bomber aircraft
 3. Helicopters
 4. Reconnaissance vehicles
- 8-5. Which of the following advantages does a semiactive radar guidance system have over an IR guidance system?
1. It has double the maneuverability
 2. It has three times the speed
 3. It has twice the range
 4. It has improved accuracy in fair weather
- 8-6. Which of the following CIS ASMs is similar to the U.S. Tomahawk cruise missile?
1. AS-15
 2. AS-10
 3. AS-7
 4. AS-3
- 8-7. Familiarity with which of the following features best facilitates shipboard missile interpretation?
1. The missile
 2. The missile launcher
 3. The ship type
 4. The ship's guns
- 8-8. Periodic inspection of the light table should be done at least how frequently?
1. Every 30 days
 2. Every 60 days
 3. Every 90 days
 4. Every 120 days

- 8-9. For complete information on light table maintenance and procedures, you should refer to which of the following publications?
1. NAVAIR 10-1-789
 2. Naval Intelligence Handbook
 3. NAVAIR 00-35QP-11
- 8-10. What type of presentation will result when oblique photographs are used in the construction of a mosaic map?
1. Flat
 2. Panoramic
 3. One-dimensional
 4. Three-dimensional
- 8-11. Mosaics are considered to be valuable assets to intelligence reporting and briefing for which of the following reasons?
1. They present a large amount of detailed information
 2. Natural and cultural features are presented in relative appearance
 3. Large areas may be quickly and easily represented
 4. Each of the above
- 8-12. What type of mosaic employs a degree of control by using data of known accuracy from a topographic map?
1. Uncontrolled
 2. Panoramic
 3. Controlled
 4. Semicontrolled
- 8-13. To minimize errors in the important portions of an uncontrolled mosaic, how should you assemble the mosaic?
1. By assembling the photographs inward toward the important area
 2. By using a number of strips which you then assemble together
 3. By assembling the photographs outward from the important area
 4. By assembling the photographs in any way appropriate to the particular case
- 8-14. When preparing to cut a print that is to be used in mosaic construction, you should perform which of the following steps?
1. Determine tonal match
 2. Determine image match
 3. Cut along natural contours
 4. Each of the above
- 8-15. Which of the following adhesive methods will allow for a print to be moved and positioned on a mounting board after the adhesive is applied?
1. Gum arabic only
 2. Rubber cement, wet mount only
 3. Rubber cement, dry mount only
 4. Rubber cement, wet or dry mount

- 8-16. Which of the following is/are the most difficult step(s) in mosaic construction?
1. Applying the adhesive only
 2. Applying the adhesive and working out the excess adhesive and air bubbles
 3. Accurate positioning of the match edge
 4. Cutting and feathering the photography
- 8-17. Which of the following methods of representing scale should be placed on the original of a mosaic?
1. Metric
 2. Bar scale
 3. Words and figures
 4. Representative fraction
- 8-18. The semicontrolled mosaic, as compared to the uncontrolled mosaic, produces which of the following results?
1. Localization of print errors
 2. Elimination of print errors
 3. Control of image distortion
 4. Elimination of image distortion
- 8-19. Precise distance and direction may be obtained from a semicontrolled mosaic.
1. True
 2. False
- 8-20. The desired overlap for mosaic construction should be 60 percent.
1. True
 2. False
- 8-21. Topographic maps are preferred as the base map for a semicontrolled mosaic.
1. True
 2. False
- 8-22. The accuracy of the finished mosaic is NOT directly related to the accuracy of the base map.
1. True
 2. False
- 8-23. It is NOT generally preferable to indicate objects or areas on a mosaic with letters or numbers.
1. True
 2. False
- 8-24. Which of the following mosaic mounting materials is sturdy, economical, and may be reused, if necessary?
1. Aluminum
 2. Plywood
 3. Cloth
 4. Tempered hardboard
- 8-25. Which of the following qualities is most desired in prints of aerial photographs that are to be used for mosaic maps?
1. Detail
 2. Contrast
 3. Composition
 4. Variable tone

- 8-26 Which of the following specifications should you include in requests for photographic prints for mosaic construction?
1. Two prints of each exposure, single-weight glossy, air dried
 2. One print of each exposure, single-weight glossy, ferrotyped
 3. Two prints of each exposure, double-weight glossy, ferrotyped
 4. One print of each exposure, double-weight glossy, ferrotyped
- 8-27. A razor blade is commonly used to cut photographic prints before they are assembled into a mosaic.
1. True
 2. False
- 8-28. Rubber cement is used to construct mosaics when absolute permanency is desired.
1. True
 2. False
- 8-29. Safety precautions must be exercised when rubber cement is being used.
1. True
 2. False
- 8-30. How should you identify and annotate functional subdivisions of primary installations on a graphic?
1. By outlining them with a broken line and assigning numbers to them
 2. By outlining them with a broken line and assigning capital letters to them
 3. By outlining them with a solid line and assigning numbers to them
 4. By outlining them with a solid line and assigning capital letters to them
- 8-31. Which of the following features, though annotated on a graphic, should NOT be attacked?
1. Open mines
 2. Radio towers
 3. Railroads
 4. Hospitals
- 8-32. When ordering mosaic or imagery graphic reproductions, you should consider which of the following factors?
1. Completeness of the titling block
 2. Selection of the reproduction paper size
 3. Establishment of proper margins
 4. Each of the above
- 8-33. Which of the following are generally accepted methods of determining scale?
1. Automated
 2. Direct measurement
 3. Both 1 and 2 above
 4. Direct obstruction

- 8-34. The relationship of the distance between two points on a photograph and the same two points on the ground is expressed in what form?
1. A whole number
 2. A fraction
 3. A decimal number
 4. A metric number
- 8-35. If a distance of 1 inch on an aerial photograph represents 2 statute miles on the ground, what is the representative fraction of the photograph?
1. $1/10,560$
 2. $3/10,560$
 3. $1/42,240$
 4. $1/126,720$
- 8-36. Which of the following factors affect(s) the precision with which measurements may be made on photography?
1. The measuring device
 2. The individual taking the measurement
 3. Photographic image quality
 4. All of the above
- 8-37. Regardless of the accuracy of the measuring device, the final result is governed by what factor(s)?
1. The skill of the interpreter
 2. Job requirements
 3. Both 1 and 2 above
 4. Photographic scale
- 8-38. Which of the following devices is NOT routinely used to make measurements on vertical photography?
1. Boxwood scale
 2. Photo plotting equipment
 3. Tube magnifier
 4. Light table optics
- 8-39. A tertiary line on a boxwood scale is equal to which of the following designations?
1. 1.000 ft
 2. 0.001 ft
 3. 0.01 ft
 4. 0.1 ft
- 8-40. Which of the following terms, if any, refers to the system of scales etched on the lens of an optical instrument?
1. Retical
 2. Refractive lens
 3. Reflective lens
 4. None of the above

A.	f
B.	E
C.	BA
D.	PSR
E.	D
F.	pd
G.	Ht
H.	MSR

Figure 8A

Figure 8A.-Scale abbreviations.

IN ANSWERING QUESTIONS 8-41 THROUGH 8-48, REFER TO FIGURE 8A.

- 8-41. What term is used to define the distance between two points on a photograph?
1. B
 2. E
 3. F
 4. H
- 8-42. What abbreviation is used to indicate the ground distance between two objects?
1. A
 2. C
 3. D
 4. E
- 8-43. Ground units on a map are identified by what abbreviation?
1. H
 2. D
 3. E
 4. F
- 8-44. Which abbreviation is used to indicate the optical system of a camera?
1. F
 2. G
 3. H
 4. A
- 8-45. The ground equivalent of a photograph is identified by what abbreviation?
1. C
 2. D
 3. E
 4. F
- 8-46. Which abbreviation is used to indicate aircraft altitude above mean terrain elevation?
1. B
 2. D
 3. G
 4. H
- 8-47. What abbreviation is used to indicate terrain elevation above mean sea level?
1. A
 2. B
 3. E
 4. G
- 8-48. Altitude, expressed in units above mean sea level, is identified by what term abbreviation?
1. C
 2. E
 3. F
 4. G
- 8-49. The photo image of a tennis doubles court, which is 12 yards wide, is measured and found to be 0.003 foot. What is the scale of the photograph?
1. 1:4,000
 2. 1:4,600
 3. 1:12,000
 4. 1:12,600

- 8-50. A CIS MOSKVA class surface ship, overall length 624.8 feet, is photographed from an altitude of 15,000 feet. The resulting photo image measures 3 inches. What is the scale of the photograph?
1. 1:2,499
 2. 1:2,823
 3. 1:20,499
 4. 1:24,992
- 8-51. The parallel lanes of a divided superhighway are found to be 0.225 foot apart on a vertical photograph. The median strip that divides the lanes is 0.075 foot wide on a map with a scale of 1/36,000. What is the scale of the photograph?
1. 1:120,000
 2. 1:108,000
 3. 1:12,000
 4. 1:10,800
- 8-52. When three points are used to determine scale by the comparison method, it is sometimes found that the scale will vary slightly on the same photograph. If this occurs, which of the following characteristics should be determined?
1. The average scale
 2. The largest scale
 3. The smallest scale
 4. The principal point
- 8-53. When you are determining scale by the comparison method, which of the following possible limitations might you encounter?
1. Maps of the area photographed may not be available
 2. If maps are available, many natural features may have changed
 3. If maps are available, many manmade features may have changed
 4. Each of the above
- 8-54. How long is an airfield runway if its image is 0.517 foot on a vertical photograph which has a scale of 1:20,000?
1. 13,868 ft
 2. 12,580 ft
 3. 10,340 ft
 4. 8.615 Ft
- 8-55. How long should a graphic scale line be to represent a ground distance of 500 feet on a 1:8,200-scale photograph of an airfield?
1. 0.061
 2. 0.164
 3. 0.410
 4. 0.870

A.	Ht
B.	Hv
C.	dsu
D.	dsk

Figure 8B

Figure 8B.-Height determination abbreviations.

IN ANSWERING QUESTIONS 8-56 THROUGH 8-60, REFER TO FIGURE 8B. ANSWERS IN FIGURE 8B MAY BE USED MORE THAN ONCE.

- 8-56. Which term refers to undetermined photographic object height?
1. A
 2. B
 3. C
 4. D
- 8-57. Which abbreviation refers to the image measurement of shadow length of an object of an unknown height?
1. A
 2. B
 3. C
 4. D
- 8-58. Which abbreviation is used to reflect absolute altitude?
1. A
 2. B
 3. C
 4. D
- 8-59. Which abbreviation refers to an image measurement of shadow length of an object of known height?
1. A
 2. B
 3. C
 4. D

- 8-60. Which abbreviation refers to the actual altitude of an aircraft above the mean terrain elevation?
1. A
 2. B
 3. C
 4. D
- 8-61. Which of the following values used in the relief displacement height determination method is the most critical to accurate results?
1. Radial distance
 2. Altitude
 3. Object displacement
 4. Photographic scale
- 8-62. Photographic image height, as determined by the relief displacement method, will be progressively more exact from the edge of the photograph toward the nadir point.
1. True
 2. False
- 8-63. A vertical object on a photograph that appears to lean or tilt away from the nadir point is said to have top displacement.
1. True
 2. False
- 8-64. Object height computed with the image displacement method should be labeled as an approximation.
1. True
 2. False

8-65. Which of the following statements concerning photographic object determination by the shadow comparison method is correct?

1. The shadow must be measured along the line related to the height of the object
2. A direct ratio exists between the height of an object and the length of its shadow
3. The shadow selected for measurement must fall on relatively level ground
4. Each of the above

8-66. The length of the shadow of a 550-foot television tower is 0.110 foot on an aerial photograph, and the length of the shadow of a nearby church steeple is 0.045 foot. What is the height of the steeple?

1. 60.5 ft
2. 139.0 ft
3. 225.0 ft
4. 247.5 ft

8-67. A tower 90 feet high casts a shadow which measures 0.039 foot on a vertical aerial photograph. Which of the following is the shadow factor that may be used to solve for other object heights on that photograph?

1. 2.307
2. 23.07
3. 3.510
4. 35.10

8-68. A photo shadow length is measured and found to be 53 thousandths of a foot long. If the shadow factor of the photograph is computed to be 1.001, what is the height of the object that casts the shadow?

1. 5.3 ft
2. 53 ft
3. 530 ft
4. 535 ft

A.	7 meters
B.	3.6 kilometers
C.	5 meters
D.	2.7 kilometers

Figure 8C

Figure 8C.-Metric conversions.

IN ANSWERING QUESTIONS 8-69 THROUGH 8-72, REFER TO FIGURE 8C.

8-69. Which of the following metric conversions corresponds to 1.94 nautical miles?

1. A
2. B
3. C
4. D

8-70. Which of the following metric conversions corresponds to 5.46 yards?

1. A
2. B
3. C
4. D

8-71. Which of the following metric conversions corresponds to 1.67 statute miles?

1. A
2. B
3. C
4. D

8-72. 22.96 feet corresponds to which of the following metric conversions?

1. A
2. B
3. C
4. D

8-73. 25 feet is equal to 8.20 meters.

1. True
2. False

8-74. 9 nautical miles is equal to 16,678.8 meters.

1. True
2. False

8-75. 6,486.2 meters is equal to 3.5 statute miles.

1. True
2. False

ASSIGNMENT 9

Textbook Assignment: "Automated Information Systems (AIS) Fundamentals";
Chapter 8, pages 8-1 through 8-24.

- 9-1. A computer can be designed to operate in which of the following configurations?
1. Stand-alone
 2. Local area networks
 3. Distributed system
 4. Each of the above
- 9-2. What component is considered to be the heart of your computer system?
1. CPU
 2. Monitor
 3. Keyboard
 4. Floppy drive
- 9-3. On which of the following boards should you find the microprocessing chip?
1. Serial board
 2. Mouse board
 3. Motherboard
 4. Cycle board
- 9-4. What is the function of the keyboard?
1. To receive output from the computer
 2. To input data into the computer only
 3. To input programs into the computer only
 4. To input data and programs into the computer
- 9-5. In addition to alphabetic characters, numbers, and special characters, keyboards have what other types of keys?
1. Control only
 2. Function only
 3. Control and function
 4. Operation
- 9-6. Which of the following is NOT a control key?
1. Escape key
 2. Delete key
 3. F1 key
 4. Shift key
- 9-7. What type of keys can be used with other keys to increase the functions of a given program?
1. Control
 2. Function
 3. Alphanumeric
 4. Numerical
- 9-8. Which of the following terms is NOT used interchangeably with the term monitor?
1. Display
 2. System unit
 3. Display device
 4. Cathode-ray tube

- 9-9. Most color monitors are of the RGB type. What does RGB mean?
1. Red-green-blue
 2. Red-gold-blue
 3. Raster gauge beam
 4. Registered global beam
- 9-10. Which of the following properties is NOT a characteristic of a disk?
1. Flat
 2. Round
 3. Direct access
 4. Sequential access only
- 9-11. Diskettes are also known by which of the following terms?
1. Floppy disk
 2. Read-only disk
 3. Write-only disk
 4. Hard disk
- 9-12. What is the purpose of formatting a diskette?
1. To make the diskette compatible to your system
 2. To create file labels on a diskette
 3. To establish a naming pattern for writing files on a diskette
 4. To set up a routine to be used to read a diskette that already contains files
- 9-13. You want to prevent data from being written on a diskette. What should you usually do to the write-protect notch if you are using a (a) 5 1/5-inch diskette and a (b) 3 1/2-inch diskette?
1. (a) Cover it
(b) cover it
 2. (a) Cover it
(b) uncover it
 3. (a) Uncover it
(b) cover it
 4. (a) Uncover it
(b) uncover it
- 9-14. Speed, large storage capacities, and convenience are all advantages of which of the following storage media?
1. Diskettes
 2. Hard disks
 3. Paper tape
 4. Magnetic tapes
- 9-15. Rigid metal platters contained in a small sealed unit either within the system unit or external to it are called what type of disk drive?
1. Colt
 2. Floppy only
 3. Hard disk only
 4. Floppy or hard disk

- 9-16. Printers used with microcomputers usually have which of the following speeds and print characters in what manner?
1. Low speed, one character at a time
 2. Low speed, one line at a time
 3. High speed, one character at a time
 4. High speed, one line at a time
- 9-17. Which of the following types of nonimpact printers can be used for both printing and plotting?
1. Laser
 2. Ink jet
 3. Electrostatic
 4. Electrosensitive
- 9-18. Which of the following types of nonimpact printers use a metallic coated paper to create characters?
1. Xerographic
 2. Electrostatic
 3. Electrothermal
 4. Electrosensitive
- 9-19. To freehand sketch or to select items from menus on a display screen, you use what device?
1. Cat
 2. Mouse
 3. Modem
 4. Optical scanner
- 9-20. CD-ROM uses a technology called WORM. What does WORM mean?
1. Write or read many
 2. Write once, read many
 3. Write or read memory
 4. Write once, read memory
- 9-21. A cable that allows devices to communicate without modems and phone lines is called a
1. convert cable
 2. phone cable
 3. null modem cable
 4. connector cable
- 9-22. To find out how to install or configure a piece of hardware, you should use what type of manual?
1. User/owner's manual
 2. Diagnostics manual
 3. Training manual
 4. Textbook
- 9-23. Which of the following sections is NOT contained in the manuals that come with a system or the software?
1. Reference
 2. Error messages
 3. Troubleshooting
 4. Standard operating procedures

- 9-24. Online tutorials that come with software packages usually have which of the following purposes?
1. To teach all the commands of the software
 2. To give you an overview of what the software can do and how it works
 3. To drill you in keying the correct information for specific applications
 4. To help you memorize all the functions and special commands
- 9-25. Keyboard templates and reference cards are useful because they provide which of the following information?
1. Detailed instructions about each feature
 2. Identification of features and associated keystrokes
 3. Keyboard schematic with a detailed description of each key and all its functions
 4. Keyboard schematic with the ASCII coding associated with each key
- 9-26. In-house user manuals have which of the following functions?
1. To implement command policy only
 2. To implement command procedures only
 3. To implement command policy and procedures
 4. To implement security regulations only
- 9-27. All microcomputer systems will have at least what type of software?
1. A window program
 2. An operating system
 3. A word processing package
 4. A data base management system
- 9-28. Before turning the power off on a microcomputer system, the user should perform which of the following actions?
1. Save his/her work
 2. Exit the program to return to the operating system
 3. Park the read/write heads if using a hard drive
 4. Reenergize the system
- 9-29. Which of the following substances may cause irreparable damage to your diskettes or computer?
1. Cigarette smoke
 2. Greasy food
 3. Beverages
 4. Each of the above
- 9-30. Diskettes are designed to withstand which of the following maximum temperature ranges?
1. 50 to 125°F
 2. 100 to 200°F
 3. 200 to 250°F
 4. 300 to 375°F
- 9-31. How far, at a minimum, should you keep all types of magnetic media, including diskettes, away from anything that generates a magnetic field?
1. 6 ft
 2. 5 ft
 3. 1 ft
 4. 1/2 ft

- 9-32. What is the extension of a file named DIAG-A.89?
1. DIAG
 2. A.89
 3. 89
 4. A
- 9-33. A file extension of "EXE" indicates what type of command?
1. Executable
 2. Executive
 3. Exemplary
 4. Exergetic
- 9-34. What term is used to describe disks having more than one directory?
1. Unstructured
 2. Static
 3. Tree structured
 4. Forested
- 9-35. To move through a tree-structured directory, you must use commands that include what name?
1. Branch name
 2. Trunk name
 3. Path name
 4. Leaf name
- 9-36. You run the risk of losing data and programs stored on disk if you do not take which of the following actions?
1. Make backup copies
 2. Enter security codes in the file name
 3. Assign a volume number and name to each disk
 4. Use subdirectories to store similar data and programs
- 9-37. To help prevent data loss and extend the life of your computer or floppy disks, you can take which of the following actions?
1. Follow a schedule of routine user maintenance
 2. Use a dust cover
 3. Clean the components on a regular basis
 4. Each of the above
- 9-38. When troubleshooting your computer system, what should be your first step?
1. Submit a trouble call
 2. Check for simple, logical answers
 3. Disassemble your CPU
 4. Clean the component

- 9-39. Packaged software does NOT include which of the following software?
1. Database
 2. Word processing
 3. Job control
 4. Spreadsheet
- 9-40. Regardless of the software package you are using, it is NOT mandatory that you be capable of executing which of the following operations?
1. Access and execute the software
 2. Save files
 3. Delete files
 4. Run diagnostics
- 9-41. To perform file management functions effectively, you must know which of the following facts about files?
1. How they are set up and coded
 2. How they are named
 3. How they are backed up
 4. All of the above
- 9-42. When you are learning how to use a software package, you should NOT take which of the following actions?
1. Take the tutorial/study the learning section
 2. Create a test file and practice on it
 3. Practice on the master data file
 4. Make mistakes on purpose to see how the software handles operator/user errors
- 9-43. Commands composed of words and/or characters predefine by the software to perform specific tasks are what type of commands?
1. Direct
 2. Indirect
 3. Execute
 4. Job
- 9-44. Function keys have which of the following purposes?
1. To perform user defined functions only
 2. To perform commonly used commands without the user having to type the command
 3. To provide user status information only
 4. To enter data and program information
- 9-45. When you are learning a new software package, what method of interfacing with the software is usually the easiest?
1. Menu
 2. Direct commands
 3. Function keys
 4. Programs/macros
- 9-46. Macros are most useful for which type(s) of task?
1. Repetitive only
 2. Complex only
 3. Awkward only
 4. Repetitive, complex, and awkward
- 9-47. What type of software package is designed primarily to work with documents?
1. Word processing
 2. Spreadsheet
 3. Graphics
 4. Database

- 9-48. What is the usual method of entering a document?
1. Type it on a keyboard
 2. Receive it over a network
 3. Input it through a scanner
 4. Import it from a desktop publishing program
- 9-49. Once entered, a document is normally stored as a data file in what way, if at all?
1. In RAM
 2. In ROM
 3. On a secondary storage medium
 4. None; documents are only printed not stored
- 9-50. You are using a word processing program and want to add new material to a document. What mode of operation should you use?
1. New
 2. Add
 3. Insert
 4. Typeover
- 9-51. To underline or center material, you should use what feature?
1. Cursor movement key
 2. Direct command
 3. Function key
 4. Macro
- 9-52. Usually, a dictionary is included with which of the following software?
1. Database
 2. Spreadsheet
 3. Word processing
 4. Desktop publishing
- 9-53. What type of software package works in columns and rows?
1. Database
 2. Spreadsheet
 3. Graphics
 4. Desktop publishing
- 9-54. In the spreadsheet, (a) what term is used to describe the entries in column A, and (b) what type of data does column A contain?
1. (a) Labels
(b) numeric
 2. (a) Labels
(b) nonnumeric
 3. (a) Values
(b) numeric
 4. (a) Values
(b) nonnumeric
- 9-55. Which of the following names is/are also used to describe a spreadsheet?
1. Array only
 2. Matrix only
 3. Worksheet only
 4. Array, matrix, and worksheet
- 9-56. What type of software package can be envisioned as a filing cabinet?
1. Graphics
 2. Database
 3. Spreadsheet
 4. Word processing
- 9-57. To access records in a database in a sequence other than the sequence in which they are stored, you can use which of the following techniques?
1. Indexes
 2. Pointers
 3. Directories
 4. Key searches

- 9-58. List databases use what technique to link records?
1. Indexes
 2. Pointers
 3. Catalogs
 4. Directories
- 9-59. What type(s) of database structure links related data elements by using superior-subordinate relationships?
1. Network only
 2. Hierarchical only
 3. Hierarchical and network
 4. Relational
- 9-60. What type of database structure enables the user to establish relationships when requesting information rather than requiring relationships be established at the time the structure is defined?
1. List
 2. Network
 3. Relational
 4. Hierarchical
- 9-61. With database software, what name is given to the type of language used to retrieve information from a database?
1. Query
 2. System
 3. Information
 4. Report generator
- 9-62. Software utilities can NOT perform which of the following functions?
1. Enhance your computer's capabilities
 2. Fill some of the voids left by operating systems and applications software
 3. Replace the need for application software to perform tasks like word processing and database
 4. Make your computer more efficient
- 9-63. Software utilities can be categorized into which of the following groups?
1. File maintenance and file management only
 2. Keyboard enhancers, DOS shell, and backup utilities only
 3. Desktop organizers, printer utilities, and virus utilities only
 4. File management, file maintenance, keyboard enhancers, DOS shell, backup utilities, desktop organizers, printer utilities, and virus utilities
- 9-64. What type of utility usually includes a calculator, notepad, phone directory, and appointment book?
1. File management
 2. File maintenance
 3. Desktop organizer
 4. Printer

9-65. File compression routines are often a feature of backup utilities. They have which of the following advantages?

1. Make data easier to read
2. Allow more data to be placed on a diskette
3. Require fewer data files for data storage
4. All of the above

9-66. File management utilities perform which of the following functions?

1. Manipulate files only
2. Manipulate directories only
3. Manipulate files and directories
4. Provide file recovery

9-67. File maintenance utilities are NOT designed to perform which of the following tasks?

1. Encrypt data
2. Repair low-level format damage on hard disks
3. Control access to resources and files
4. Organize files and set file attributes

9-68. Which of the following is the best description of a computer virus?

1. A series of simple instructions that are intentionally designed to degrade or destroy your computer files
2. A series of complex instructions that are intentionally designed to degrade or destroy your computer files
3. Accumulated condensation inside your computer's hard disk
4. Accumulated condensation on your floppy diskettes

9-69. When printing maps with a computer software program, you most likely will find the information stored in which of the following media?

1. Floppy disk
2. CD-ROM
3. High capacity disk or tape
4. Both 2 and 3 above

